

**PIUSI**

















**FUEL  
CATALOGUE  
09-2024**

# FUEL PRODUCT RANGE

PRODUCT RANGE	PRODUCT CATEGORY	PRODUCT	PAG	
<b>FUEL MANAGEMENT SYSTEM</b>	FUEL MANAGEMENT SYSTEM		OVERVIEW	8
		SOFTWARE	B.SMART	10
		DISPENSER	ADD-ONS	12
			CUBE B.SMART	14
			CUBE B.SMART PROEIGHT	16
			SELF SERVICE B.SMART	18
		CONTROL BOX	MCBOX B.SMART	20
	PIUSI SUPREME	PIUSI 3000 SUPREME B.SMART	22	
		SOFTWARE	SSM2.0	24
		DISPENSER	DATA TRANSFER SSM 2.0	26
			CUBE MC 2.0	28
			SELF SERVICE MC 2.0	30
			SELF SERVICE FM 2.0	32
		CONTROL BOX	MCBOX 2.0	34
		SOFTWARE	SSM AGILIS	36
		DISPENSER	DATA TRANSFER AGILIS	38
CUBE MC			40	
CONTROL BOX		SELF SERVICE MC	42	
		MCBOX	44	
<b>DISPENSERS</b>	MEHCANICAL DISPENSER			
		CUBE	50	
		SELF SERVICE K44	52	
<b>KITS</b>	ATEX KITS			
	DRUM	EX50 DRUM	58	
		EX100 DRUM	60	
		EX140 DRUM	62	
	MOBILE	DRUM	64	
		PICO	66	
		BATTERY KIT	68	
		PITSTOP	70	
		PIUSIBOX	72	
		CARRY	74	
	ST	ST	76	
		ST WITH METER	78	
		ST WITH METER AND FILTER	80	
		ST BOX	82	
ST 200 AC		84		
ST 200 DC		86		
<b>PUMPS</b>	ATEX AC PUMPS			
	ATEX DC PUMPS	EX100	92	
		EX140	94	
		EX50 / EX75 DC	96	
	AC PUMPS	EXGO!	98	
		PANTHER AC	100	
		VISCOMAT VANE	102	
		E80 / E120	104	
		E140	106	
		E300	108	
	NEW! OVERVIEW PIUSI SUPREME DC PUMPS	<b>PIUSI 3000 SUPREME</b> OVERVIEW	110	
		PIUSI 3000 SUPREME	112	
		BP3000	114	
		PANTHER DC	116	
		BIPUMP	118	
	HAND PUMPS	PIUSI HAND PUMP	120	
HAND PUMPS		122		

All Pictures shown are for illustration purpose only. Actual product may vary due to product enhancement.

PRODUCT RANGE	PRODUCT CATEGORY	PRODUCT	PAG
<b>METERS</b> 	ATEX ELECTRONIC METERS 	K24 ATEX 	128
	ATEXMECHANICAL METERS 	K33 ATEX 	130
		K150 ATEX 	132
	ELECTRONIC METERS	K24	134
		K600/3	136
		K600 B/3	138
		K600/4	140
		K700 PULSER	142
		K900	144
		REMOTE DISPLAY	146
	MECHANICAL METERS	K90	148
		K33 / K44	150
		K150	152
K700		154	
<b>NOZZLES</b> 	ATEX AUTOMATIC NOZZLES 	A60 / A140 ATEX 	160
	AUTOMATIC NOZZLES	A60 / A80 / A120 / A140	162
		A280	164
	MANUAL NOZZLES	SELF 2000 / SELF 3000	166
<b>FILTRATION</b> 	FILTERING SYSTEM	FILTROLL	172
	FILTERS	WATER CAPTOR	174
		CLEAR CAPTOR	176
		FUEL & BIOFUEL	178
		FOOT VALVE	180
<b>TANK MONITORING</b> 	TANK LEVEL INDICATORS	OCIO	184
		OCIO 2.0	186
<b>HOSE REEL</b> 	OPEN HOSE REEL	DIESEL HOSE REEL	192
<b>ACCESSORIES</b> 	ACCESS CONTROL	ACCESS 85	198
	ACCESSORIES	CONNECTORS	200
		COUPLING&FITTINGS	202
		FLANGED CONNECTIONS	204
		HOSE&SWIVEL	206
<b>MERCHANDISE</b> 	MERCHANDISE		212

# THE HISTORY OF “KNOW-HOW”

## ABOUT US

**PIUSI was established in 1953 in Suzzara, in the province of Mantua (Italy).** For more than 60 years, **PIUSI has been the major player in the world’s leading markets with its full range of products for transferring, refilling and measuring lubricants, fuels and liquids such as gasoline, diesel, Diesel Exhaust Fluid (DEF), oil, water and grease.**

Some of PIUSI’s main products include pumps, flow meters, nozzles, dispensers, hose reels, liquid level gauges, software and complete kits used by operators in agriculture, the automotive industry, workshops and garages, fleet management and transport by road and by sea. PIUSI products have many different uses such as monitoring and transferring fuel at trucking companies, refueling of agricultural vehicles, transferring fuels in construction and mining for heavy duty vehicles. The products are intuitive and easy to use; are suitable to be installed in a variety of contexts; are all made entirely in Italy; and all products express the innovation, quality, professionalism and R&D that have always distinguished PIUSI. Its headquarters are in Suzzara (Mantova - 150 km from Milan and Venice). The company currently employs more than 250 employees between sales, administration, R&D, production and logistics. PIUSI products are sold in more than 120 countries around the world thanks to a large network of distributors and the US branch based in Fort Lauderdale, FL, serving the North and South American markets.

1953

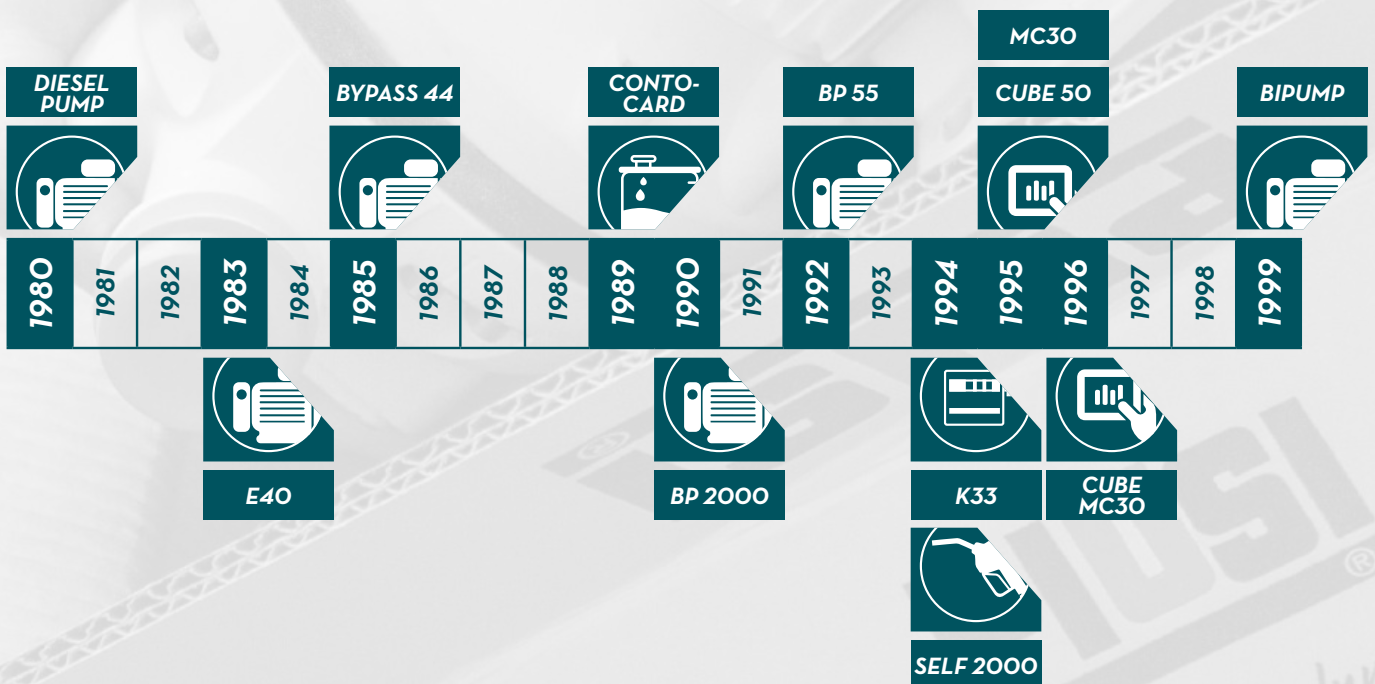

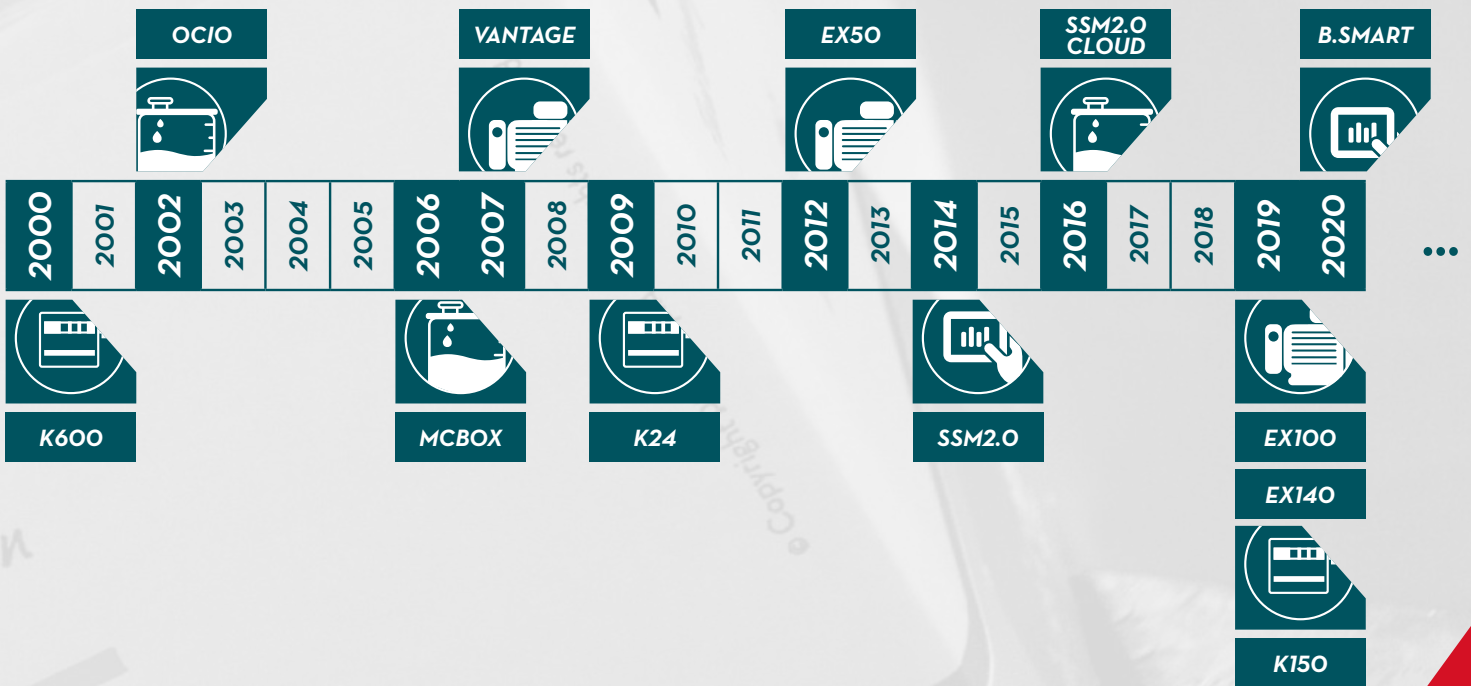



# **FUEL MANAGEMENT SYSTEMS**

A solid red triangle is positioned in the bottom right corner of the page, pointing towards the top left. It is a simple, flat-colored geometric shape that adds a modern, dynamic touch to the minimalist design.



# OVERVIEW

## FEATURES:

### ACCURATE DATA

- REAL AND ACCURATE CONSUMPTIONS' DATA ON EACH REFUELLING OPERATION MANAGED AUTOMATICALLY BY THE SYSTEM;
- OVERVIEW ON CONSUMPTIONS' TREND AND AVAILABLE RESIDUAL FUEL;

### REDUCED COSTS

- CAREFUL AND MEASURED CONSUMPTION OF FUEL ALLOWS TO SAVE UP TO 10% OF FUEL EVERY YEAR

### NO ABUSE

- A FUEL MANAGEMENT SYSTEM ALLOWS YOU TO TRACK WHO IS MAKING THE PROCEDURE, ON WHICH VEHICLE ALSO INDICATING THE DISPENSER USED IN ORDER TO CONTAIN ABUSES.

Fuel Management Systems (FMS) are technologically-advanced equipment that allow to measure, control and manage the consumptions of fuel (or other fluids) of fleets or other Company vehicles (such as for example the earth moving machines within the construction industry).

The consumption of fuel, diesel and petrol is an important part of the running costs of a fleet.

- How much fuel have you wasted in the past few months?
- How much fuel does each vehicle or driver consume?
- What was the trend of consumptions?

To have a clear and precise overview on the situation, you need a FMS.

A system linked to your dispensers and stations for fuel transferring that follow and trace all the refuelling operations also indicating who is the operator and the vehicle which is refuelled; all in real time.

PIUSI has developed 3 different FMS software suitable for all different requirements: B.SMART, SSM 2.0 and SELF SERVICE MANAGEMENT AGILIS.

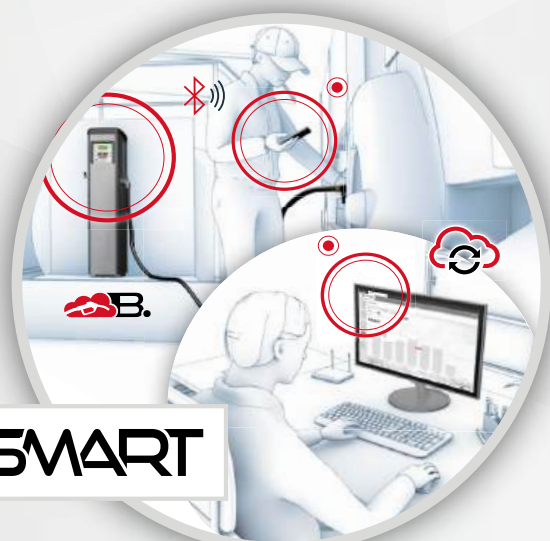





FILTRATION



TANK MONITORING



HOSE REEL



ACCESSORIES



MERCHANDISE

# PIUSI

INDEX

ANY BIODIESEL

AIR

ANTIFREEZE

AdBlue®

BIODIESEL

DIESEL

FOOD

GASOLINE

GREASE

KEROSENE

OIL

WATER

WINDSCREEN

## Why choose a PIUSI FMS?

With 70 years of history, PIUSI can supply not only all the technological and IT aspects of the software, but also - integrated - a wide range of dispensers suitable for all needs.

By choosing PIUSI, you will have - from a single supplier - not only the Software, but also the dispensing Hardware directly from the same Company.



**Dispensing control ideal for:**  
company that wants to monitor the quantity delivered.



**Consumption control ideal for:**  
a company that wants to monitor and manage the quantities supplied, manage consumption and supply of fuels.



**Dispensing control ideal for:**  
company that wants to monitor and manage the quantities delivered in the cloud without territorial limitations, with smart technologies.

		AGILIS SELF SERVICE MANAGEMENT	SSM 2.0 SELF SERVICE MANAGEMENT	B.SMART
<b>GENERAL</b>	PLATFORM	PC Software	PC Software	Cloud Software
	MULTISITE	-	with PW mobile	YES
	MAX USERS	250/Dispenser	up to 1000	Unlimited
	MAX DISPENSERS	16	up to 20	Unlimited
	USER LOGIN	iButton/Pincode	iButton/Pincode	Mobile App
<b>LIMIT SETTINGS</b>	REMOTE USER/DISPENSER DEACTIVATION	-	YES	YES
	USER DAY/WEEKLY LIMITS	-	YES	with Fuel Economy Add-on
	VEHICLE LIMITS	-	YES	with Fuel Economy Add-on
<b>MANAGEMENT: • VEHICLES • SUPPLIERS • CONSUMPTIONS</b>	REGISTRATION NUMBER	Manual entry	iButton	Mobile App
	USER VEHICLE ASSIGNMENT	-	YES	YES
	ODOMETER	YES	YES	YES
	EXTERNAL TRANSACTIONS	-	YES	with Fuel Economy Add-on
	FUEL CONSUMPTION MANAGEMENT	-	YES	with Fuel Economy Add-on
	ADBLUE CONSUMPTION MANAGEMENT	-	YES	with Fuel Economy Add-on
	FLUID SUPPLIERS MANAGEMENT	-	YES	with Tank Watchdog Add-on
<b>TANK LEVEL MANAGEMENT</b>	TANK LOW LEVEL PUMP CUT-OFF	YES	YES	YES
	REMOTE TANK LEVEL MANAGEMENT	-	YES	with Tank Watchdog Add-on
	MAX NO. OCIO	-	up to 20	Unlimited - with Tank Watchdog Add-on
<b>TANK ALARM</b>	SOFTWARE ALARMS	YES	YES	YES
	HARDWARE ALARMS (W/OCIO)	-	YES	YES
<b>REPORT</b>	TRANSACTION REPORT	YES	YES	YES
	TANK LEVEL REPORT	-	YES	with Tank Watchdog Add-on
	FUEL PRICE TREND REPORT	-	YES	with Tank Watchdog Add-on

IBUTTON: IN CASE OF EMERGENCY IF/OR SMARTPHONE IS ABSENT OR IT DOESN'T WORK



# B.SMART

## FEATURES

- SIMPLE, INTUITIVE, SUITABLE FOR EVERYONE
- UNLIMITED TO FIT ALL NEED
- MONO OR MULTI-SITE
- SOFTWARE ALWAYS INCLUDED WITH THE DISPENSER
- BLUETOOTH
- CLOUD-BASED
- NO SOFTWARE INSTALLATION
- NO FEE
- ANALYSIS, CONTROL AND MANAGEMENT IN ONE CLICK

B.SMART is the Fuel Management System (FMS) by PIUSI designed and engineered for fleets of all sizes: small, medium, large, mono or multi-site. Innovative, simple and smart - the name carries its meaning - PIUSI B.SMART combines the quality and efficiency of PIUSI dispensers, with a Cloud-based software (APP for drivers and a web APP for fleet managers) driven by Bluetooth technology; that means no Wi-Fi or LAN network are required. Thus, it is possible to use B.SMART wherever; also in the more distant areas.

A FMS all in one: the fleet manager has just to choose the necessary dispensers; the software is always included in the "package" (no rental ore recurring fee will be required).

### PERFORMANCE

<p>DATA</p> <p><b>AVAILABLE</b></p> <p>ALWAYS</p> <p>TRANSACTIONS</p>	<p>NO</p> <p><b>SOFTWARE</b></p> <p>ON THE PC</p> <p>CLOUD</p>
<p><b>NO FEE</b></p> <p>UTILIZATION</p>	<p><b>BLUETOOTH</b></p> <p>NO WI-FI OR LAN</p> <p>CONNECTION</p>



## B.SMART

B.SMART is flexible and expandable: the same system easily fits to all requirements. It is only necessary to add the add-on needed to keep up with the evolution of the fleet.

### B.SMART API AVAILABLE

CONNECT YOUR ERP TO B.SMART WITH THE INTEGRATED API INTERFACE.





FILTRATION



TANK MONITORING



HOSE REEL



ACCESSORIES



MERCHANDISE

INDEX



ANY BIODIESEL



AIR



ANTIFREEZE



AdBlue®



BIODIESEL



DIESEL



FOOD



GASOLINE



GREASE



KEROSENE



OIL



WATER



WINDSCREEN



## APP

Dedicated to drivers, the APP for drivers just needs a smart device with Bluetooth to work properly: once the APP is open, the smartphone or tablet immediately connects to the dispenser to start the refueling operation.



## HARDWARE

PIUSI B.SMART runs only with the dedicated range of dispensing devices: quality guaranteed by PIUSI; the highest technical performances and reliability, all form a unique supplier. Real time communication between the dispenser and the PC.



## CLOUD

The core of B.SMART fuel management software is a Cloud-based service that tracks every refuelling operation and keeps every device synchronized.



## WEB APP

Dedicated to fleet manager. No software installation: just log in and start immediately to monitor, manage and control consumptions of the fleet.



# ADD-ONS



## ADD-ON

Once the ADD-ON is chosen, PIUSI will send an activation code with all related instructions.

### DRIVER ADD-ON

CODE	DESCRIPTION
F22500000	DRIVER ACCESS ADD-ON B.SMART (X10)
FO0770D20	DRIVER ACCESS ADD-ON B.SMART (X50)

## TANK WATCHDOG

B.SMART Tank Watchdog is the perfect add on for a complete and updated control of the stock. It allows you to:

- monitor the tank level (add fluid loads and unloads and adjustments);
- set level alarms;
- manage suppliers;
- follow inventory price values and trends;
- access and download reports from anywhere

### TANK WATCHDOG ADD-ON

CODE	DESCRIPTION
FO0770L00	B.SMART TANK WATCHDOG ADD-ON - 1 YEAR
FO0770L20	B.SMART TANK WATCHDOG ADD-ON - ONE TIME FEE

## Tank levels

Adding the level indicator OCIO, the system allows you to monitor the fluid level in your tanks in real time and gives alarms in case of malfunction or low levels. A perfect add-on for a complete and updated control of the stock. You can connect also any 420 mA o O-10 V fluid gauge or run the system without any gauge thanks to the “virtual tank” option:

- set level alarms and get notifications on the tank level;
- possibility to configure high level or low level alarms;
- stop the pump according to the level of the fluid;
- send an automatic e-mail to notify when you reach the level alarm set.

## Fluid price and values

Thank to the level indicator OCIO you can have at your fingertips the fluid inventory value & quantity: you can define the refuelling price and verify the current inventory value.

- manage suppliers of the fluids to keep track of the date, price and quantity bought;
- get real time data of the value of your inventory;
- follow fluids price trends;
- access and download reports from any internet connected device thanks to the software cloud.

## FUEL ECONOMY

Enhance your system and become even more smart with the Fuel Economy ADD-ON for B.SMART! Thanks to this new module, you can now completely manage and increase the profitability of your fleet:

- manage consumptions, cross-checking vehicles and drivers;
- manage drivers' and vehicles' limits;
- add, check and manage the on-road refuellings.





FILTRATION



TANK MONITORING



HOSE REEL



ACCESSORIES



MERCHANDISE



ANY BIODIESEL



AIR



ANTIFREEZE



AdBlue®



BIODIESEL



DIESEL



FOOD



GASOLINE



GREASE



KEROSENE



OIL



WATER



WINDSCREEN

## Fleet management & limits

Thanks to this new add-on, you can:

- add to the B.SMART WEB APP system all the vehicles of your fleet;
- group all the vehicles according to a specific and personalized setting;
- add to the WEB APP the images of your vehicles and drivers for a quickest and easy identification;
- set drivers and vehicles limits based on quantities or time frames

### FUEL ECONOMY ADD-ON

CODE	DESCRIPTION
FO0770FOO	B.SMART FUEL ECONOMY ADD-ON 1 YEAR
FO0770F20	B.SMART FUEL ECONOMY ADD-ON ONE TIME FEE
F17299Q00	B.SMART FUEL ECONOMY 45 QR CODES

## Consumptions report

Thanks to this new add-on, you can have detailed reports of:

- fuel/AdBlue® dispenses;
- vehicles' consumptions, spotting deviations vs standard;
- drivers' consumption on vehicles, tracking the driving behaviour of the operator;
- spot drivers' high fuel consumption;
- add on-road transactions highlighting also fuel/AdBlue® costs and the service station used in order to have a complete overview on the trend/activities of both drivers and vehicles.

## MAPLY

The add-on is specifically designed for companies working in construction, mining, excavation, drilling, landscaping or agriculture that want to have all the information at-a-glance including GPS location of fuel dispensing. With Maply Add-on it is possible:

- reduce fuel waste
- increase company profitability
- monitor & control fuel dispensing

## Geolocation

- Geolocate fuel transactions and display them on a map;
- "report on map" gives an overview of fuel dispensing. Clicking on a fuel transaction you get all the relevant data (quantity, date, time, vehicle refuelled, etc.)

## Manage fluid handover from fixed to mobile tanks

- Automatically manage portable tank loads;
- fuel transfer information will be managed inside the B.Smart reporting system, increasing information effectiveness.

## 3rd parties vehicles refuelling

- Track fuel transactions on third-party vehicles;
- possibility to send e-mail notifications and add operator's notes.

### MAPLY ADD-ON

CODE	DESCRIPTION
FO0770M00	B.SMART MAPLY ADD-ON - 1 YEAR
FO0770M20	B.SMART MAPLY ADD-ON - ONE TIME FEE

## AVAILABLE KITS ADD-ON

### KIT ADD-ON

CODE	DESCRIPTION
FO0770K00	KIT TANK WATCHDOG + FUEL ECONOMY 1 YEAR
FO0770K20	KIT TANK WATCHDOG + FUEL ECONOMY ONE TIME FEE
FO0770K40	KIT TANK WATCHDOG + FEM + MAPLY 1 YEAR
FO0770K60	KIT TANK WATCHDOG + FEM + MAPLY ONE TIME FEE



# CUBE B.SMART

## FEATURES

- STURDY STRUCTURE
- COMPACT DESIGN
- NATIVE WITH B.SMART CLOUD SOFTWARE
- KIT UPGRADE 1.0/2018 AVAILABLE
- IP55

The CUBE B.SMART fuel dispenser, available in the 70 and 90 litre/min versions with both AC and DC supply, is equipped with a self-priming vane pump with built-in bypass that ensures high performance. The anti-vibration support of the diesel dispenser guarantees silent operation and practicality, while the mechanical seal and the thermal protection of the induction motor against overheating make the product reliable and safe. CUBE B.SMART is equipped with an automatic nozzle with swivel connection. The installation of the mesh filter on the suction side ensures the pump longevity, as it prevents foreign bodies from ending up in the rotor and causing a blockage and consequent damage.

### PERFORMANCE

<b>UP TO 90 L/MIN</b>	<b>AC/DC</b>
FLOW RATE	VOLTAGE
<b>± 0,5%</b>	<b>BLUETOOTH</b>
ACCURACY	CONNECTION



### PACKAGING

CODE	WEIGHT		PACKAGING			N. BOXES / EUROPALLET	
	KG	LBS	MM	INCH	PCS/BOX	✕	🚛
FO0598000	24	53	380X380X480	15,0X15,0X18,9	1	-	-
FO0598010	24	54	380X380X480	15,0X15,0X18,9	1	-	-
FO0598A1A	20	44	380X380X480	15,0X15,0X18,9	1	-	-
FO0598AOA	20	44	380X380X480	15,0X15,0X18,9	1	-	-



FILTRATION



TANK MONITORING



HOSE REEL



ACCESSORIES



MERCHANDISE

# PIUSI

INDEX

B

ANY BIODIESEL

A

AIR

A

ANTIFREEZE

Ad

AdBlue®

B

BIODIESEL

D

DIESEL

F

FOOD

G

GASOLINE

G

GREASE

K

KEROSENE

O

OIL

W

WATER

W

WINDSCREEN

## CHART

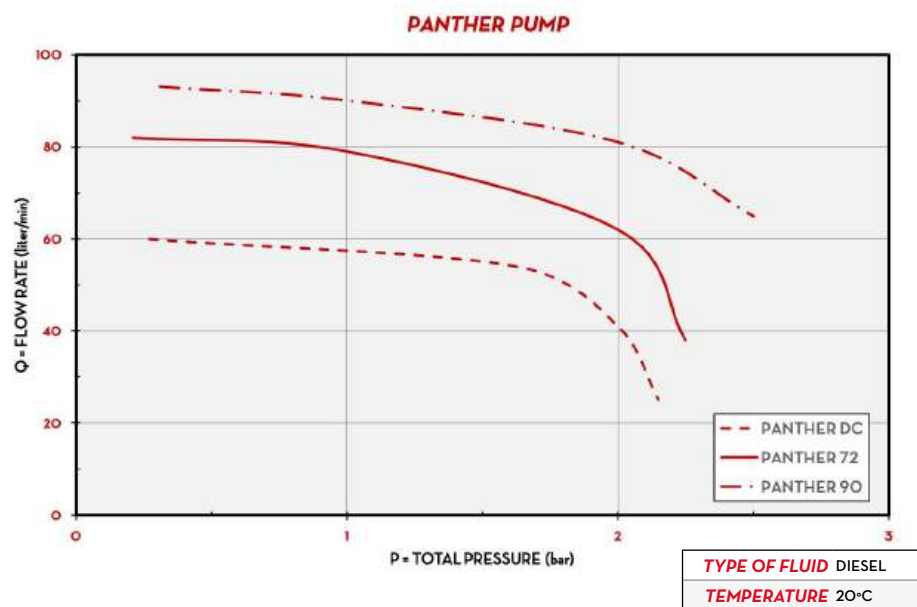

## DIMENSIONS

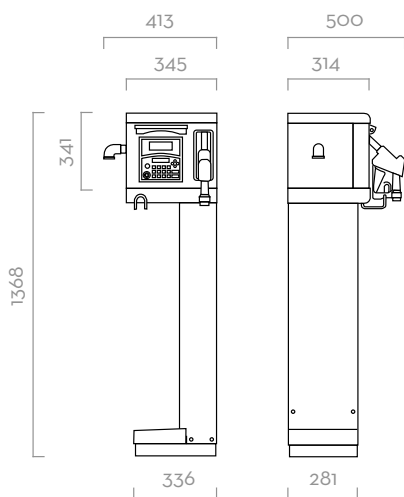

Dimensions expressed in millimeters

## IN THE BOX

- CUBE B.SMART DISPENSER
- AUTOMATIC NOZZLE
- DELIVERY HOSE
- DRIVER ACCESS ADD-ON
- INSTRUCTION MANUAL

## DETAILS



SHUTTER



B.SMART MOBILE APP



## MATERIALS

- **PUMPS:**  
PANTHER AC  
PANTHER DC
- **METER:**  
K600/3
- **NOZZLE:**  
AUTOMATIC NOZZLE

## TECHNICAL DATA

CODE	DESCRIPTION	FLUIDS TYPE	FLOW RATE		VOLTAGE			PUMP	METER	NOZZLE	FILTER	INLET	HOSE		
			L/MIN	GPM	AC V./HZ	DC VOLT	POWER WATT						AMP. MAX.	LENGTH	Ø
FO0598000	CUBE 70 230V B.SMART 10 DIVERS	D	70	18	230 V	50 HZ	900 W	4,2 A	PANTHER 72	K600/3	A60	NO	1"	4M	25MM
FO0598010	CUBE 90 230V B.SMART 10 DIVERS	D	90	24	230 V	50 HZ	900 W	4,9 A	PANTHER 90	K600/3	A120	NO	1"	4M	25MM
FO0598A1A	CUBE 70 B.SMART 24V 10 ACCESS	D	70	18	24V	-	420W	25 A	PANTHER DC	K600/3	A70	NO	1"	4M	25MM
FO0598AOA	CUBE 12 V B.SMART · 10 DRIVERS	D	56	15	12 V	-	300W	35 A	PANTHER DC	K600/3	A60	NO	1"	4M	25MM



# CUBE B.SMART PRO8IGHT

## FEATURES

- STURDY STRUCTURE
- COMPACT DESIGN
- NATIVE WITH B.SMART CLOUD SOFTWARE
- INTEGRATED HOSE REEL
- INTEGRATED WATER CAPTOR FILTER
- IP55

CUBE B.SMART PROEIGHT dispenser is the new PIUSI product designed to meet the needs of the market. Thanks to the integration with the 8-meter 26-feet hose reel, CUBE B.Smart becomes even more compact, intuitive and easy to use. It is equipped with a self-priming vane pump with built-in bypass that delivers high performance refueling. The anti-vibration mounting ensures low noise and vibration, while the mechanical sealing and overheating protection of the motor enhances the product reliability and safety. The new CUBE B.SMART dispenser with hose reel is equipped with PIUSI WATER CAPTOR, a new filter designed to absorb particles of water that may be in the liquid.

### PERFORMANCE

<p>UP TO</p> <p><b>60 L/MIN</b></p> <p>FLOW RATE</p>	<p><b>AC/DC</b></p> <p>VOLTAGE</p> <p>HOISE LENGTH</p>
<p><b>30 µm</b></p> <p>WATER CAPTOR FILTER</p>	<p><b>BLUETOOTH</b></p> <p>CONNECTION</p>



CUBE B.SMART  
**Pro8ight**



### PACKAGING

CODE	WEIGHT		PACKAGING			N. BOXES / EUROPALLET	
	KG	LBS	MM	INCH	PCS/BOX	X	
FO0598800	57	125	1480X490X400	58,2X19X15	1	-	-





FILTRATION



TANK MONITORING



HOSE REEL



ACCESSORIES



MERCHANDISE

# PIUSI

INDEX



ANY BIODIESEL



AIR



ANTIFREEZE



AdBlue®



BIODIESEL



DIESEL



FOOD



GASOLINE



GREASE



KEROSENE



OIL



WATER



WINDSCREEN

## CHART

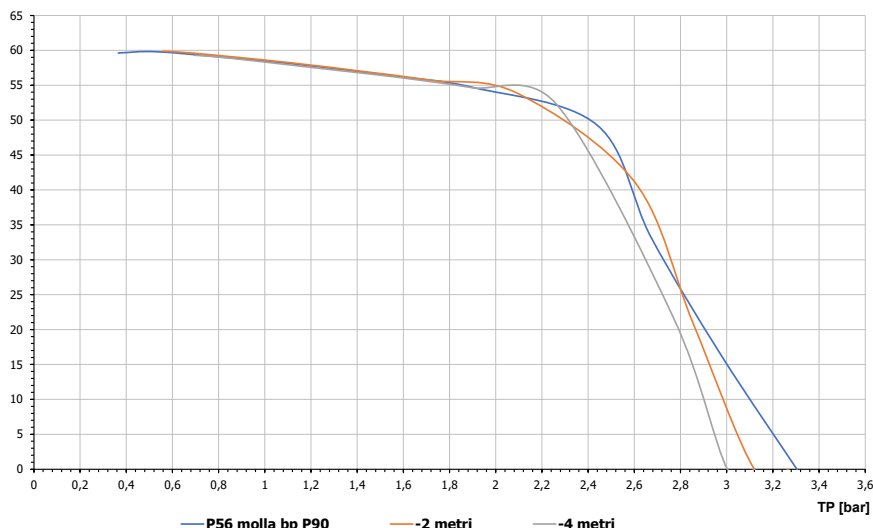

TYPE OF FLUID DIESEL

TEMPERATURE 20°C

## DIMENSIONS

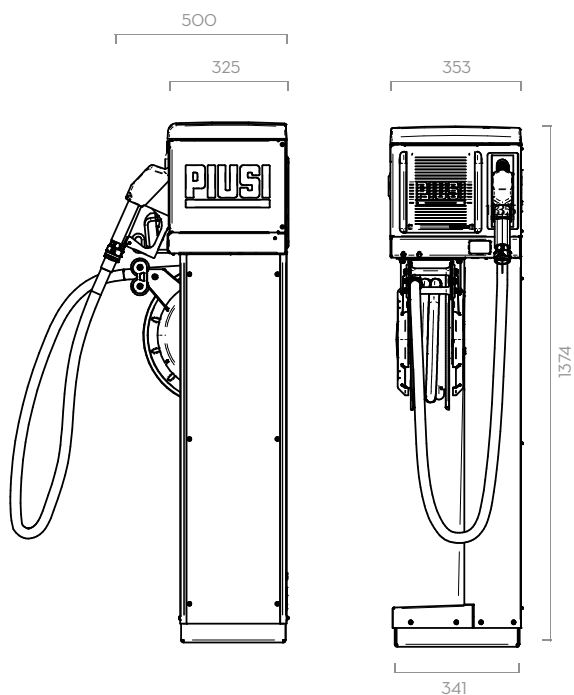

Dimensions expressed in millimeters

## IN THE BOX

- CUBE B.SMART PRO8IGHT DISPENSER
- AUTOMATIC NOZZLE
- DELIVERY HOSE
- DRIVER ACCESS ADD-ON
- INSTRUCTION MANUAL

## DETAILS



INTEGRATED HOSE REEL



B.SMART MOBILE APP



B.SMART CLOUD SOFTWARE



INTEGRATED WATER CAPTOR FILTER

## MATERIALS

- PUMPS:  
PANTHER AC
- METER:  
K600/3
- NOZZLE:  
AUTOMATIC NOZZLE

## TECHNICAL DATA

CODE	DESCRIPTION	FLUIDS TYPE	FLOW RATE		VOLTAGE			PUMP	METER	NOZZLE	FILTER	INLET	HOSE		
			L/MIN	GPM	AC V./HZ	POWER WATT	AMP. MAX.						TYPE	LENGTH	Ø
FO0598800	CUBE 70 B.SMART 230V PRO8IGHT 10 ACCESS	D	60	16	230V	50HZ	600W	2,7 A	PANTHER 72	K600/3	A60	YES	1"	8MT	20MM



FUEL MANAGEMENT SYSTEMS



DISPENSERS



KITS



PUMPS



METERS



NOZZLES

# SELF SERVICE B.SMART

## FEATURES

- FUEL MANAGEMENT SYSTEM B.SMART INTEGRATED
- NO SOFTWARE INSTALLATION REQUIRED
- SUITABLE FOR FLEETS OF ALL SIZES
- REAL TIME FEEDBACK FROM ANYWHERE
- BUILT-IN FILTER
- ALL-IN-ONE EQUIPMENT
- COMPACT DESIGN
- KIT UPGRADE 1.0/2018 AVAILABLE

Top quality diesel dispenser by PIUSI, combined with the innovative B.SMART fuel management system: this is the core of the new SELF SERVICE B.SMART. A complete device specifically engineered to fit all diesel transfer needs while performing all the features of a fuel management software in terms of monitoring, controlling and managing the consumption of fuel by the fleet.

This dispenser performs: a sturdy design to ensure proper function in any working condition, a vane pump with incorporated bypass for a high flow rate (up to 90 l/min) and an oval gear meter to ensure maximum precision in measurement. An automatic nozzle with swivel connection, ergonomic and easy to handle, and a water absorption filter completes its components.

## PERFORMANCE

UP TO <b>90 L/MIN</b>	<b>AC</b>
FLOW RATE	VOLTAGE
<b>± 0,5%</b>	<b>BLUETOOTH</b>
ACCURACY	CONNECTION



## PACKAGING

CODE	WEIGHT		PACKAGING			N. BOXES / EUROPALLET	
	KG	LBS	MM	INCH	PCS/BOX	✗	
FO0748010	57	125	1480X490X400	58,3X19,3X15,7	1	-	-
FO0748000	61	133	1480X490X400	58,3X19,3X15,7	1	-	-



FILTRATION



TANK MONITORING



HOSE REEL



ACCESSORIES



MERCHANDISE

# PIUSI

INDEX



ANY BIODIESEL



AIR



ANTIFREEZE



AdBlue®



BIODIESEL



DIESEL



FOOD



GASOLINE



GREASE



KEROSENE



OIL



WATER



WINDSCREEN

## CHART

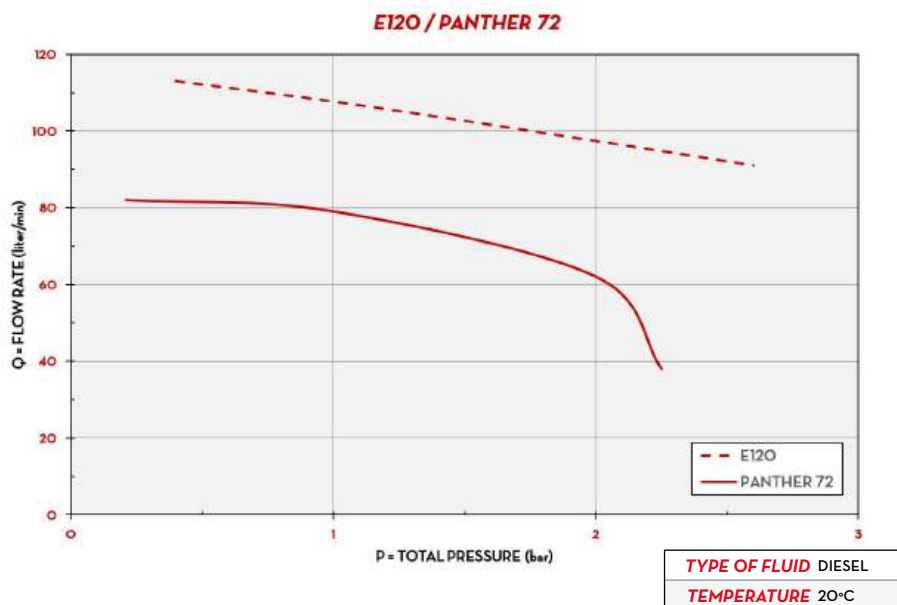

## DIMENSIONS

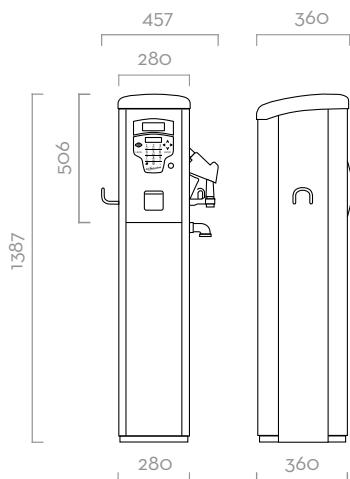

Dimensions expressed in millimeters

## IN THE BOX

- SELF SERVICE B.SMART DISPENSER
- DELIVERY HOSE
- AUTOMATIC NOZZLE
- DRIVER ACCESS ADD-ON
- INSTRUCTION MANUAL

## DETAILS



SHUTTER



B.SMART MOBILE APP



B.SMART CLOUD SOFTWARE



WATER CAPTOR FILTER

## MATERIALS

- PUMPS:  
PANTHER 72 / E120
- METER:  
K600/3
- NOZZLE:  
AUTOMATIC NOZZLE
- FILTER:  
WATER CAPTOR

## TECHNICAL DATA

CODE	DESCRIPTION	FLUIDS TYPE	FLOW RATE		VOLTAGE			PUMP	METER	NOZZLE	FILTER	INLET	HOSE		
			L/MIN	GPM	AC V./HZ	DC VOLT	POWER WATT						AMP. MAX.	LENGTH	Ø
FO0748010	SELF SERVICE 70 230V B.SMART 10 DRIVERS	D	70	18	230 V	50 HZ	550 W	3,3 A	PANTHER 72	K600/3	A80	30 µM	11/2"	4M	25MM
FO0748000	SELF SERVICE 100 230V B.SMART 10 DRIVERS	D	90	24	230 V	50 HZ	1150 W	5,7 A	E120	K600/3	A120	30 µM	11/2"	4M	25MM



FUEL MANAGEMENT SYSTEMS



DISPENSERS



KITS



PUMPS



METERS



NOZZLES

# MCBOX B.SMART

## FEATURES

- IDEALS FOR EXISTING PLANTS
- SUITABLE FOR ANY PUMPS
- PULSE METER INPUT
- NATIVE WITH B.SMART CLOUD SOFTWARE

MCBOX is an electronic control panel that allows you to control any type of AC/DC pump, pulser litre-counter, nozzle and fuel level switches. The perfect product to upgrade an existing installation or for a customized assembly. With MC BOX B.SMART the B.SMART fuel management system is integrated. No need for software to be installed on a PC: B.SMART works in the Cloud and allows you to monitor all fuel transactions in real time, from any site where MCBOX B.SMART is installed. Communication between MCBOX B.SMART, Phone App and Cloud Software is simple.

### PERFORMANCE

**AC/DC**

VOLTAGE

UP TO  
**500**  
STORABLE  
TRANSACTIONS

**2 PUMPS  
VERSION**

OUTPUT

**BLUETOOTH**

CONNECTION



### PACKAGING

CODE	WEIGHT		PACKAGING			N. BOXES / EUROPALLET	
	KG	LBS	MM	INCH	PCS/BOX	✈	🚚
FO0599000	5,2	11,5	300X300X180	11.8X11.8X7.1	1	-	-
FO0599200	5,3	11,6	300X300X180	11.8X11.8X7.1	1	-	-
FO0599150	5,4	11,8	300X300X180	11.8X11.8X7.1	1	-	-



FILTRATION



TANK MONITORING



HOSE REEL



ACCESSORIES



MERCHANDISE

## INDEX



ANY BIODIESEL



AIR



ANTIFREEZE



AdBlue®



BIODIESEL



DIESEL



FOOD



GASOLINE



GREASE



KEROSENE



OIL



WATER



WINDSCREEN

### CONNECTION SCHEME



PUMP CONTROL



PULSE METER INPUT



TANK LEVEL INDICATOR



NOZZLE SWITCH



### IN THE BOX

- MCBOX B.SMART UNIT
- DRIVER ACCESS ADD-ON
- INSTRUCTION MANUAL

### DETAILS



SHUTTER



B.SMART MOBILE APP



B.SMART CLOUD SOFTWARE



EASY ACCESS TO CONNECTION

### DIMENSIONS

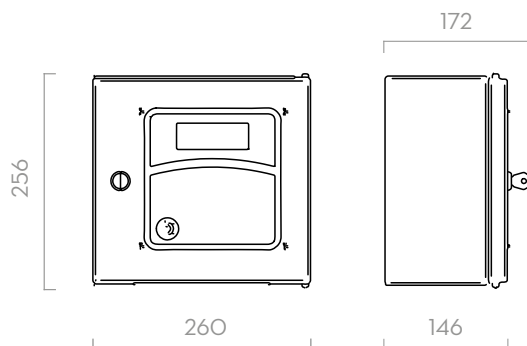

Dimensions expressed in millimeters

### TECHNICAL DATA

CODE	DESCRIPTION	FLUIDS TYPE	VOLTAGE			B.SMART CLOUD	
			AC V/HZ DC VOLT	POWER WATT	AMP. MAX.		
FO0599000	MCBOX 100-240V B.SMART 10 DRIVERS	ANY	100V-240V	50/60 HZ	5W	15 A	INCLUDED
FO0599200	MCBOX 100-240V B.SMART 10 DRIVERS 2 PUMPS	ANY	100V-240V	50/60 HZ	5W	15 A	INCLUDED
FO0599150	MCBOX B.SMART 12V/24V 10 ACCESS	ANY	12/24 V	-	5W		INCLUDED



FUEL MANAGEMENT SYSTEMS



DISPENSERS



KITS



PUMPS



METERS



NOZZLES

# PIUSI 3000 SUPREME B.SMART

## FEATURES

- VOLTAGE FROM 12 TO 24V\*
- BLUETOOTH CONNECTION
- TOTAL CONTROL VIA APP
- VIBRATION RESISTANCE
- LOW NOISE
- COMPATIBLE WITH DIESEL UP TO B20 - HVO/XTL
- MAX. PRESSURE 1,5 BAR
- IP55

Piusi 3000 Supreme B.SMART represents a breakthrough in transportable tanks, combining safety, efficiency and management. Thanks to its cutting-edge technology and full integration with the Fuel Management System B.SMART, Piusi 3000 Supreme B.SMART gives users the ability to control every aspect of their dispensing and fleet operations, enabling them to achieve unprecedented levels of performance and reliability.

If you aim for maximum efficiency and safety for your transportable tanks, Piusi 3000 Supreme B.SMART is the best choice.

### PERFORMANCE

UP TO <b>50 L/MIN</b>	FROM <b>12V TO 24V*</b>
FLOW RATE	VOLTAGE
CONTINUOUS DUTY	<b>±0,5%</b>
DUTY CYCLE	ACCURACY

\* The Piusi 3000 Supreme does not have the ability to monitor the battery and does not provide any type of protection for it.



### PACKAGING

CODE	WEIGHT		PACKAGING		
	KG	LBS	MM	INCH	PCS/BOX
FO025IH00	5,4	11,9	270X190X180	-	1
FO025IV00	5,4	11,9	270X190X180	-	1
FO025ID00	7,4	16,3	300X300X180	-	1
FO025IK00	10	22	490X390X310	-	1
FO025ID10	11,5	25,3	490X390X310	-	1



FILTRATION



TANK MONITORING



HOSE REEL



ACCESSORIES



MERCHANDISE

## INDEX



ANY BIODIESEL



AIR



ANTIFREEZE



AdBlue®



BIODIESEL



DIESEL



FOOD



GASOLINE



GREASE



KEROSENE



OIL



WATER



WINDSCREEN

### IN THE BOX FOR FOLLOWING CONFIGURATIONS:

<b>BASE BRACKET KIT</b>	PUMP ELECTRIC CABLE 4M ACCESS KEY (1PZ) INSTRUCTION MANUAL	+	DELIVERY HOSE
FOO251KOO			AUTOM. NOZZLE A60 + HOOK
<b>2" DIRECT MOUNT KIT</b>			BASE BRACKET
FOO251D1O			DELIVERY HOSE
			AUTOM. NOZZLE A60 + HOOK
		+	NOZZLE HOLDER
<b>PUMP ONLY DRUM</b>			DRUM CONNECTOR 2"
FOO251DOO			OIL & FUEL FILTER
<b>PUMP ONLY B.O. &amp; PUMP ONLY B.V.</b>			BASE BRACKET
FOO251HOO			
FOO251VOO			

## WEB APP



### DETAILS



BENDING PROTECTION



ELECTRIC CABLE



OIL & FUEL FILTER



AUTOMATIC NOZZLE A60

### DIMENSIONS

#### BASE BRACKET KIT

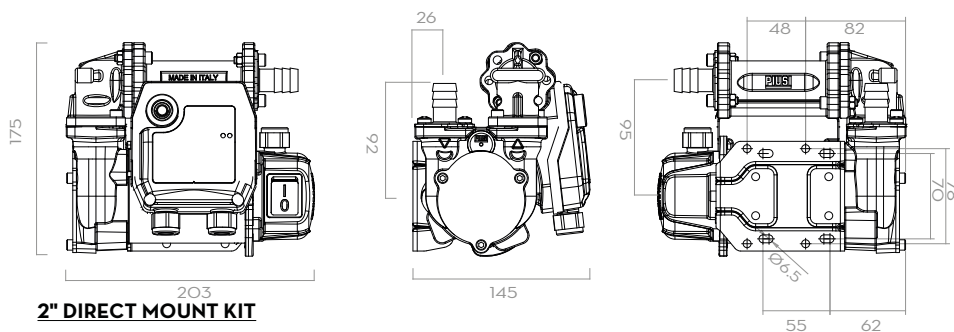

#### 2" DIRECT MOUNT KIT

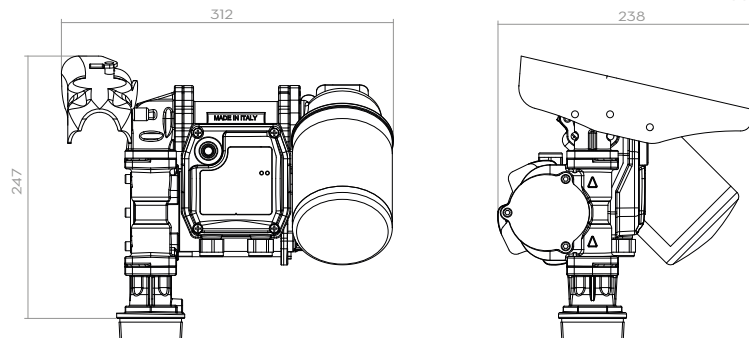

Dimensions expressed in millimeters

### MATERIALS

- BODY: CAST IRON
- ROTOR: SINTERED STEEL
- VANES: ACETAL RESIN
- SEAL: NBR
- SHAFT: STEEL

### ACCESSORIES

- AUTOMATIC NOZZLE A60 + HOOK  
COD. FOO603S00 (2" DIRECT MOUNT KIT)
- AUTOMATIC NOZZLE A60 COD. FOO603060  
(BASE BRACKET KIT)
- DIESEL HOSE 4M (COD. F24103000)

### TECHNICAL DATA

CODE	DESCRIPTION	FLUIDS TYPE	FLOW RATE		VOLTAGE			RPM	DUTY CYCLE CONTINUOUS	FUSES CAPACITY AMPERE	HOSE		DIRT FILTER	NOZZLE
			L/MIN	GPM	DC VOLT	POWER WATT	AMP. MAX.				LENG.	Ø		
FOO251HOO	PIUSI 3000 SUPREME PUMP ONLY B.O.	D	50	13	FROM 12 TO 24	200W	16A/8A	2700	YES	25A	-	-	-	-
FOO251VOO	PIUSI 3000 SUPREME PUMP ONLY B.V.	D	50	13	FROM 12 TO 24	200W	16A/8A	2700	YES	25A	-	-	-	-
FOO251DOO	PIUSI 3000 SUPREME PUMP ONLY DRUM	D	50	13	FROM 12 TO 24	200W	16A/8A	2700	YES	25A	-	-	YES	-
FOO251KOO	PIUSI 3000 SUPREME BASE BRACKET KIT	D	50	13	FROM 12 TO 24	200W	16A/8A	2700	YES	25A	4MT	3/4"	-	A60
FOO251D1O	PIUSI 3000 SUPREME 2" DIRECT MOUNT KIT	D	50	13	FROM 12 TO 24	200W	16A/8A	2700	YES	25A	4MT	3/4"	YES	A60



# SSM2.0

## FEATURES

- TANK WATCHDOG
- DRIVERS/VEHICLES MANAGEMENT
- REPORT
- FLUID INVENTORY VALUE

The new SELF SERVICE MANAGEMENT 2.0 software is the most advanced response for management and monitoring of refueling, allowing supervision of drivers, vehicles and fuel tanks. Setting up the system and getting to work has never been easier: simply connect the devices to your LAN or Wi-Fi network and click on the "Detect System" button on your PC. SELF SERVICE MANAGEMENT 2.0 will handle the rest. Use of the SELF SERVICE MANAGEMENT 2.0 software requires the new range of SELF SERVICE 2.0 dispensing devices. The ibutton key reader kit is available on request.

### PERFORMANCE

UP TO  
**1000**

DIVERS / VEHICLES

**USB/WEB**  
SOFTWARE VERSION

INSTALLATION

### SOFTWARE ACTIVATION MODE



**USB  
HARDWARE KEY**  
without internet  
connection



**WEB  
EDITION**  
internet connection  
required







FILTRATION



TANK MONITORING



HOSE REEL



ACCESSORIES



MERCHANDISE

# PIUSI

INDEX



ANY BIODIESEL



AIR



ANTIFREEZE



AdBlue®



BIODIESEL



DIESEL



FOOD



GASOLINE



GREASE



KEROSENE



OIL



WATER



WINDSCREEN

### CHECK

The cost of the consumption for every distance.



### VIEW

Bar charts easily allow you to analyze the liters delivered each day and compare them with the average use.

### VEHICLES

Reads the average consumption and distance driven.



### TANK MONITORING

Check the liters delivered over the period you specify.



The system min. requirements are:

- Monitor resolution 1280x700
- CPU: Intel® Pentium® 4 or AMD Athlon® 64 processor (2 GHz or higher)
- RAM: 2 GB
- Free space on Hard Disk: 20 GB
- Operating system: Windows 10 TH1 1507 or next version, Windows Server 2016 or next version
- Database: Microsoft SQL 2019 CU16 Express (included in the installation)

### TECHNICAL DATA - USB CODE

CODE	DESCRIPTION
FO0772050	SSM 2.0 ENTRY
FO077202A	SSM 2.0 ADVANCED
FO077204A	SSM 2.0 SUITE
FO0772000	SSM 2.0 CLIENT

### TECHNICAL DATA - WEB CODE

CODE	DESCRIPTION
FO0772250	SSM 2.0 ENTRY - WEB EDITION
FO077222A	SSM 2.0 ADVANCED - WEB EDITION
FO077224A	SSM 2.0 SUITE - WEB EDITION
FO0772200	SSM 2.0 CLIENT - WEB EDITION

THE PURCHASE OF ADDITIONAL CLIENT LICENSES ENABLES YOU TO USE THE VARIOUS VERSIONS OF SELF SERVICE MANAGEMENT 2.0 ON MULTIPLE WORKSTATIONS.



# DATA TRANSFER SSM2.0

Among the equipment related to SSM 2.0, PIUSI has developed a set of technological solutions able to connect the electronic/mechanical device to the fluid control system, that is the software that organizes the operation of the hardware; in this case SELF SERVICE MANAGEMENT 2.0. How does data transfer with SSM2.0 work? It depends on the technology required.

### Direct downloading

Use your Manager Key to transfer the data from dispenser to PC: it is enough to touch the dispenser with the key and then use the key reader to transfer the data collected.

### LAN/Wi-Fi

The way to receive in real time all information regarding the transactions: using PWLAN or PW WiFi the software recognizes the fuel dispensers and it will automatically send the data to the SELF SERVICE MANAGEMENT 2.0 software.

### Mobile Network

The brand-new PW MOBILE 4G 2.0 allows to install dispenser wherever desired, even in the most remote area, without the need of a local network: the device uses the mobile 4G technology to communicate and transfer data.





FILTRATION



TANK MONITORING



HOSE REEL



ACCESSORIES



MERCHANDISE

BIS

ANY BIODIESEL

A

AIR

A

ANTIFREEZE

Ad

AdBlue®

B

BIODIESEL

D

DIESEL

F

FOOD

G

GASOLINE

G

GREASE

K

KEROSENE

O

OIL

W

WATER

W

WINDSCREEN

### PW MOBILE



A new communication system that allows you to transfer data using mobile 4G network.

### KEY READER & MANAGER KEY 2.0



### LAN



A network card that allows the RS485 signal to be converted for connection to a LAN, through a simple and intuitive interface.

### PW WI-FI



A device that allows to convert the RS485 signal to Wi-Fi, through a simple and intuitive interface.

## TECHNICAL DATA

CODE	DESCRIPTION
F1226201A	KIT KEY READER SELF SERVICE 2.0
F20552010	MANAGER KEY 2.0 (GREY)
F1271012A	PW WI-FI 2.0
F12710130	PW MOBILE 4G 2.0



# CUBE MC 2.0

## FEATURES

- STURDY STRUCTURE
- BUILT-IN LAN ADAPTER
- COMPACT DESIGN
- SSM 2.0 SOFTWARE REQUIRED
- IP55
- IDEAL FOR FUEL MANAGEMENT

The PIUSI CUBE MC 2.0 is the perfect solution for those who need safe and simple, high-volume fuel dispensing operations while checking transactions and managing their own fleet. The system is equipped with the same main feature of the CUBE MC, and includes a built-in LAN connection. SSM 2.0 Software required.

### PERFORMANCE

UP TO  
**90 L/MIN**

FLOW RATE

UP TO  
**1000**

USERS

**± 0,5%**

ACCURACY



CUBE MC 2.0



CUBE MC 2.0 WITH PEDESTAL (OPTIONAL)

### PACKAGING

CODE	WEIGHT		PACKAGING			N. BOXES / EUROPALLET	
	KG	LBS	MM	INCH	PCS/BOX	✕	
FO059600B	25	55	400X400X460	-	1	12	24
FO059610B	25	55	400X400X460	-	1	12	24



FILTRATION



TANK MONITORING



HOSE REEL



ACCESSORIES



MERCHANDISE

# PIUSI

INDEX

B

ANY BIODIESEL

A

AIR

A

ANTIFREEZE

Ad

AdBlue®

B

BIODIESEL

D

DIESEL

F

FOOD

G

GASOLINE

G

GREASE

K

KEROSENE

O

OIL

W

WATER

W

WINDSCREEN

## CHART

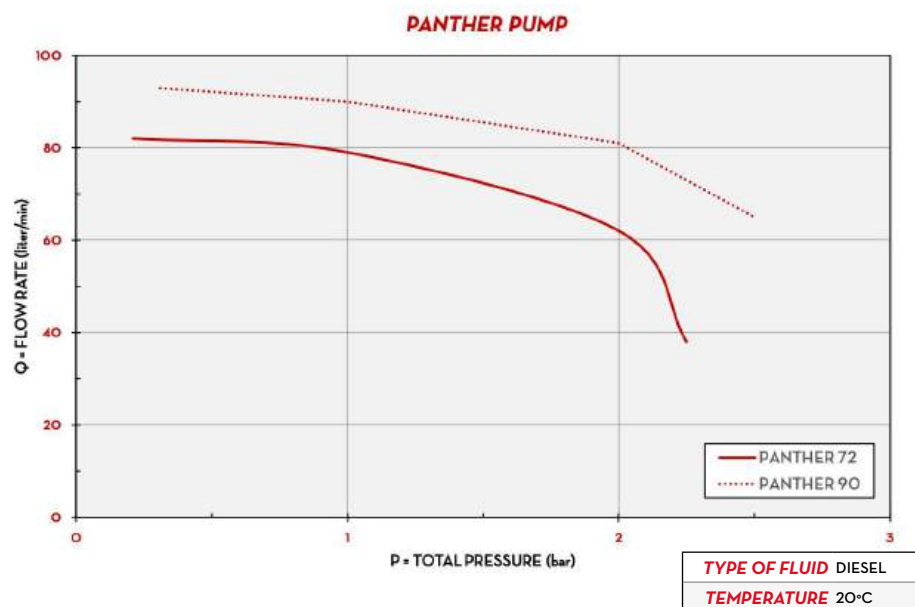

## DIMENSIONS

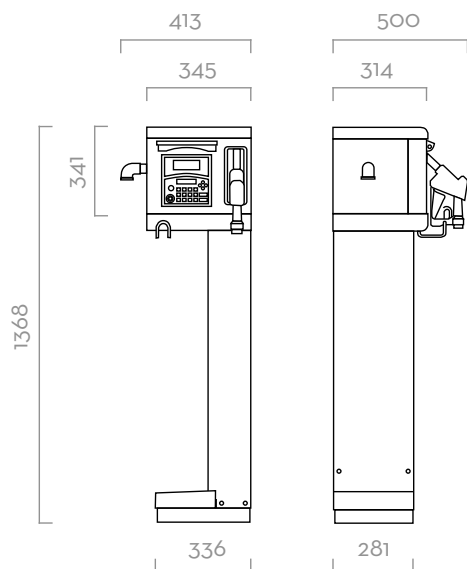

Dimensions expressed in millimeters

## IN THE BOX

- CUBE MC 2.0 DISPENSER
- AUTOMATIC NOZZLE
- DELIVERY HOSE
- INSTRUCTION MANUAL

## DETAILS



SHUTTER



USER&VEHICLE KEY (n.i.)



SSM 2.0 SOFTWARE



DATA TRANSFER SSM2.0

## MATERIALS

- **PUMPS:**  
PANTHER AC  
PANTHER DC
- **METER:**  
K600/3
- **NOZZLE:**  
AUTOMATIC NOZZLE

## TECHNICAL DATA

CODE	DESCRIPTION	FLUIDS TYPE	FLOW RATE		VOLTAGE			PUMP TYPE	METER TYPE	NOZZLE TYPE	FILTER H2O FILTER	INLET BSP	HOSE LENGTH METERS	SELF SERVICE MANAGEMENT 2.0
			L/MIN	GPM	AC V/HZ DC VOLT	POWER WATT	AMP. MAX.							
FO059600B	CUBE 70 MC 2.0	D	70	18	230/50	900	4,9	PANTH 72	K600	A60	NO	1"	4	REQUIRED
FO059610B*	CUBE 90 MC 2.0	D	90	23,8	230/50	900	4,9	PANTH 90	K600	A120	NO	1"	4	REQUIRED

\*DUTY CYCLE 30MIN ON/OFF



# SELF SERVICE MC 2.0

## FEATURES

- STURDY STRUCTURE
- ALL-IN-ONE DISPENSER
- BUILT-IN LAN ADAPTER
- FRONT DOOR FOR EASY MAINTENANCE
- SSM 2.0 SOFTWARE REQUIRED
- IP55
- IDEAL FOR FUEL MANAGEMENT

The PIUSI SELF SERVICE MC 2.0 is a non-commercial fuel diesel dispenser able to fit any fleet management requirement. It requires the SSM 2.0 software to work. Equipped with 90 l/min continuous duty pump, it is suitable for any fleet dimension.

### PERFORMANCE

UP TO <b>90 L/MIN</b>	<b>AC</b> CONTINUOUS DUTY
FLOW RATE	VOLTAGE
<b>± 0,5%</b>	UP TO <b>1000</b>
ACCURACY	USERS



ELECTRONIC METER INTEGRATED



SELF SERVICE MC 2.0

### PACKAGING

CODE	WEIGHT		PACKAGING			N. BOXES / EUROPALET	
	KG	LBS	MM	INCH	PCS/BOX	✈	🚚

#### COLUMN VERSION

FO074302B	75	165	1478X488X400	-	1	6	4
-----------	----	-----	--------------	---	---	---	---



FILTRATION



TANK MONITORING



HOSE REEL



ACCESSORIES



MERCHANDISE

# PIUSI

INDEX

BIS

ANY BIODIESEL

A

AIR

A

ANTIFREEZE

Ad

AdBlue®

B

BIODIESEL

D

DIESEL

F

FOOD

G

GASOLINE

G

GREASE

K

KEROSENE

O

OIL

W

WATER

W

WINDSCREEN

### CHART

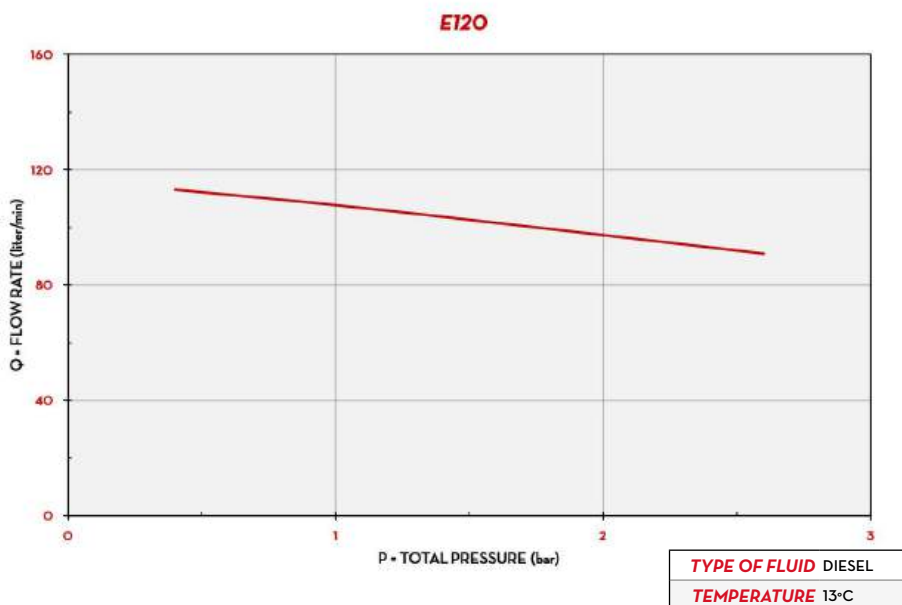

### DIMENSIONS

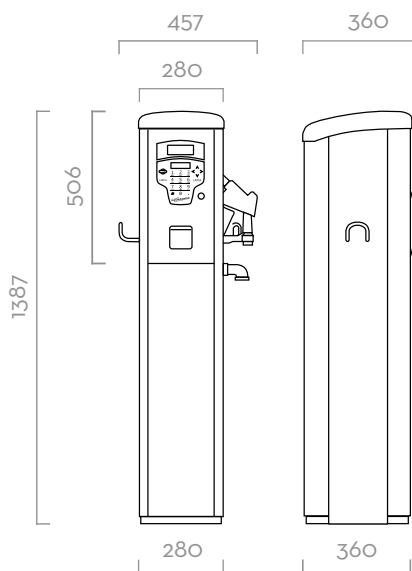

Dimensions expressed in millimeters

### IN THE BOX

- SELF SERVICE MC 2.0 DISPENSER
- DELIVERY HOSE
- AUTOMATIC NOZZLE
- INSTRUCTION MANUAL

### DETAILS



WATER CAPTOR FILTER



DRIVER&VEHICLE KEY (n.i.)



SSM 2.0 SOFTWARE



DATA TRANSFER SSM2.0

### MATERIALS

- **PUMPS:**  
E80 / E120
- **METER:**  
K600/3
- **NOZZLE:**  
AUTOMATIC NOZZLE
- **FILTER:**  
WATER CAPTOR

### TECHNICAL DATA

CODE	DESCRIPTION	FLUIDS TYPE	FLOW RATE		VOLTAGE			PUMP TYPE	METER TYPE	NOZZLE TYPE	FILTER		INLET BSP	HOSE LENGTH METERS	SELF SERVICE MANAGEMENT 2.0
			L/MIN	GPM	AC V/HZ DC VOLT	POWER WATT	AMP. MAX.				H2O FILTER	FILTERING CAPACITY			

#### COLUMN VERSIONS

FO074302B	SELF SERVICE 100 MC 2.0	<b>D</b>	90	24	230/50	1150	5,7	E120	K600	A120	YES	30µ	1" 1/2	4	REQUIRED
-----------	-------------------------	----------	----	----	--------	------	-----	------	------	------	-----	-----	--------	---	----------



# SELF SERVICE FM 2.0

## FEATURES

- IDEAL FOR FUEL MANAGEMENT
- TANK LEVEL INDICATOR
- TICKET PRINTER
- MULTI-USER MANAGEMENT
- STURDY STRUCTURE
- EASY MAINTENANCE
- HIGH DISPLACEMENT VANE PUMP
- SSM 2.0 SOFTWARE REQUIRED
- IP55

The PIUSI SELF SERVICE FM 2.0 is the top-level, all-in-one dispenser for fuel with integrated LAN connection to guarantee continuous communication between dispenser and PC, water captor filter to ensure the highest purity of fluids, OCIO 2.0 tank level indicator and an electronic panel able to manage up to 1000 users and 650 transactions. Compatible with SSM 2.0 software.

### PERFORMANCE

UP TO <b>90 L/MIN</b>	<b>AC</b> CONTINUOUS DUTY
FLOW RATE	VOLTAGE
<b>± 0,5%</b>	UP TO <b>1000</b>
ACCURACY	USERS



INTEGRATED TICKET PRINTER



SELF SERVICE FM 2.0

### PACKAGING

CODE	WEIGHT		PACKAGING			N. BOXES / EUROPALLET	
	KG	LBS	MM	INCH	PCS/BOX	✈	🚚

#### COLUMN VERSION

FO074301A	75	165	1478X488X400	-	1	6	4
-----------	----	-----	--------------	---	---	---	---





FILTRATION



TANK MONITORING



HOSE REEL



ACCESSORIES



MERCHANDISE

# PIUSI

INDEX

B

ANY BIODIESEL

A

AIR

A

ANTIFREEZE

Ad

AdBlue®

B

BIODIESEL

D

DIESEL

F

FOOD

G

GASOLINE

G

GREASE

K

KEROSENE

O

OIL

W

WATER

W

WINDSCREEN

## CHART

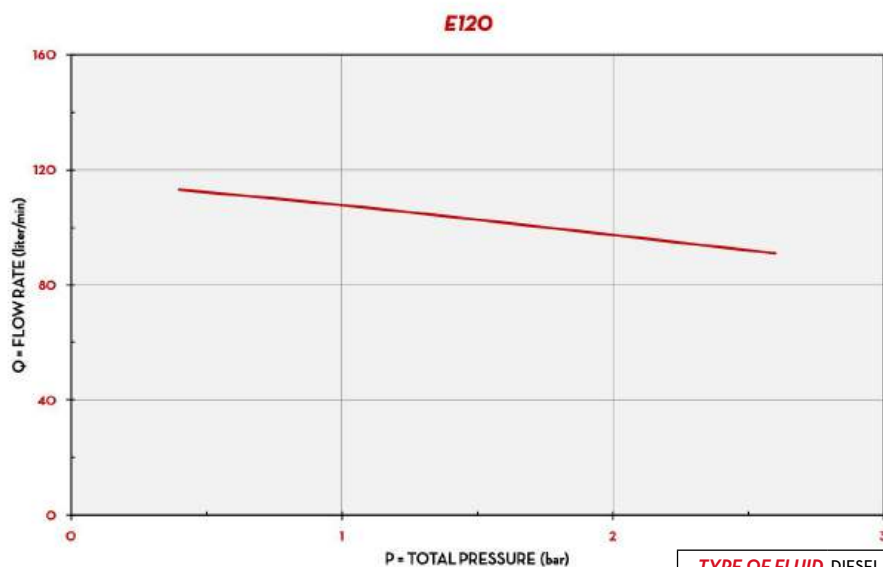

**TYPE OF FLUID** DIESEL  
**TEMPERATURE** 13°C

## DIMENSIONS

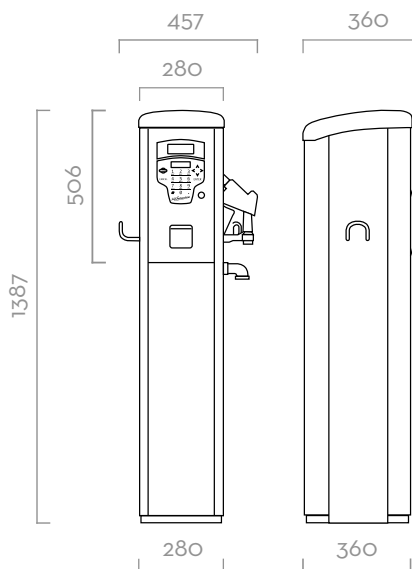

Dimensions expressed in millimeters

## IN THE BOX

- SELF SERVICE FM 2.0 DISPENSER
- DELIVERY HOSE
- AUTOMATIC NOZZLE
- INSTRUCTION MANUAL

## DETAILS



## MATERIALS

- **PUMP:**  
E120
- **METER:**  
K600/3
- **NOZZLE:**  
AUTOMATIC NOZZLE
- **FILTER:**  
WATER CAPTOR

## TECHNICAL DATA

CODE	DESCRIPTION	FLUIDS TYPE	FLOW RATE		VOLTAGE			PUMP TYPE	METER TYPE	NOZZLE TYPE	FILTER		INLET BSP	HOSE LENGTH METERS	SELF SERVICE MANAGEMENT 2.0
			L/MIN	GPM	AC V/ HZ DC VOLT	POWER WATT	AMP. MAX.				H2O FILTER	FILTERING CAPACITY			

### COLUMN VERSIONS

FO074301A	SELF SERVICE 100 FM 2.0	<b>D</b>	90	24	230/50	1150	5,7	E120	K600	A120	YES	30µ	1" 1/2	4	REQUIRED
-----------	-------------------------	----------	----	----	--------	------	-----	------	------	------	-----	-----	--------	---	----------



# MCBOX 2.0

## FEATURES

- FLEET MANAGEMENT
- SUITABLE FOR ANY PUMP
- PULSE METER INPUT
- LAN/WI-FI VERSION AVAILABLE
- SSM2.0 SOFTWARE REQUIRED

The PIUSI MCBOX 2.0 is the evolution of the MCBOX system thanks to the integration with the 2.0 features: fuel consumption monitoring and report, fleet management, vehicles and users control. It is suitable to manage and control an existing pump, pulse meter and nozzle.

### PERFORMANCE

UP TO  
**1000**

USERS / VEHICLES

**AC**  
VOLTAGE

POWER



MC BOX 2.0



### PACKAGING

CODE	WEIGHT		PACKAGING		
	KG	LBS	MM	INCH	PCS/BOX
FO059701A	6	13,2	300X300X330	11,8X11,8X13	1
FO059702A	6	13,2	300X300X330	11,8X11,8X13	1



FILTRATION



TANK MONITORING



HOSE REEL



ACCESSORIES



MERCHANDISE

## INDEX



ANY BIODIESEL



AIR



ANTIFREEZE



AdBlue®



BIODIESEL



DIESEL



FOOD



GASOLINE



GREASE



KEROSENE



OIL



WATER



WINDSCREEN

## CONNECTION SCHEME



## IN THE BOX

- MCBOX 2.0 UNIT
- LAN OR WI-FI ADAPTER
- INSTRUCTION MANUAL

## DETAILS



## DIMENSIONS

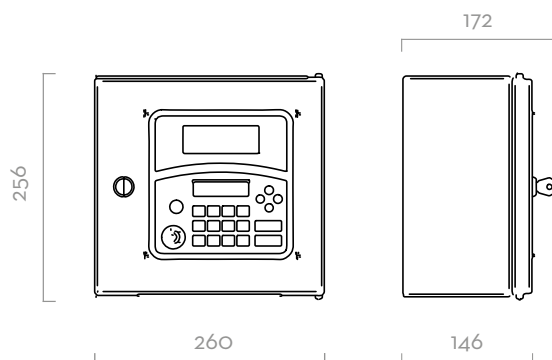

Dimensions expressed in millimeters

## TECHNICAL DATA

CODE	DESCRIPTION	FLUIDS TYPE	CONNECTION	VOLTAGE			SSM 2.0 SOFTWARE
				AC V/Hz	POWER WATT	AMP. MAX. (load motor)	
FO059701A	MCBOX LAN 2.0 90-240V 50/60HZ	A Ad B D F G G K O W W	LAN	90-240 V 50/60 HZ	10	50	REQUIRED
FO059702A	MCBOX 2.0 WIFI 90-240V 50/60HZ	A Ad B D F G G K O W W	WI-FI	90-240 V 50/60 HZ	10	25	REQUIRED



FUEL MANAGEMENT SYSTEMS



DISPENSERS



KITS



PUMPS



METERS



NOZZLES

# SSM AGILIS

## FEATURES

- VIRTUAL TANK MONITORING
- EASY INSTALLATION
- REPORT TRANSACTION
- CUSTOMIZABLE EXPORTS

AGILIS products can be used on their own, but with the SSM AGILIS software they become true allies of the company owner.

This software is constantly being developed and updated by PIUSI, so much so that it is the benchmark for all entry-level fuel management systems to easily, and comprehensively, monitor dispensing in every company vehicle.

## AGILIS IS THE IDEAL SYSTEM FOR SMALL & MEDIUM ENTERPRISES

### PERFORMANCE

UP TO

16

DISPENSERS

**USB/WEB**  
SOFTWARE VERSION

INSTALLATION

### SOFTWARE ACTIVATION MODE



**USB  
HARDWARE KEY**  
without internet  
connection



**WEB  
EDITION**  
internet connection  
required





FILTRATION



TANK MONITORING



HOSE REEL



ACCESSORIES



MERCHANDISE

## An effective system for small and medium enterprises that use their own tanks for refuelling their work vehicles with diesel

- Offers a wide range of solutions in terms of applications, dispenser type and voltage
- Authorises access to fuel simply and automatically, by means of a PIN or yellow key
- Manages up to 250 users per dispenser
- Monitors tank level (virtual tanks only)
- Records all dispensing data
- Easy to connect to your computer in the way that suits you best: PW14, PW Mobile, PW Lan, PW Wifi, Manager Key
- Exports full, custom reports
- Works both with and without dedicated software

### BENEFITS



Prevents losses and unauthorised withdrawals



Prevents machine downtimes caused by fuel shortages



Optimises reporting, thereby freeing up company resources



Provides long service-life due to its rugged construction, high quality and ease of use



### TECHNICAL DATA

CODE	DESCRIPTION
FO0773050	SELF SERVICE MANAGEMENT AGILIS - USB
FO0773250	SELF SERVICE MANAGEMENT AGILIS - WEB



# DATA TRANSFER AGILIS

DATA TRANSFER SSM AGILIS is a set of different solutions that let to download the transactions from the dispensers to the SELF SERVICE MANAGEMENT AGILIS software. The great variety of the offer is based on the technology required.

### Manual download

The easiest way to download the informations is through the Manager key, it is enough to touch the dispenser with the key to transfer all the transactions and download them on the software.

### Local network

Use the local network Lan/Wi-Fi to download the dispenser to your pc. By choosing between the PWLAN or PW Wi-Fi it is possible to set up a connection that let you receive all the transactions in real time.

### Mobile network

Thanks to the new PW MOBILE 4G is now possible to install all the dispensers everywhere in the world with just the need of a mobile network coverage, with SIM card, avoiding all the local network configurations.



PW14 / RS 485

MANAGER KEY

PW-LAN

PW-WIFI

PW-MOBILE





FILTRATION



TANK MONITORING



HOSE REEL



ACCESSORIES



MERCHANDISE

### PW14 / RS 485



Connection via RS485 cable with USB converter.

### KEY READER, MANAGER KEY & MANAGER KEY USB TYPE C



### PW LAN



A device that allows to convert the RS485 signal to LAN, through a simple and intuitive interface.

### PW WI-FI



A device that allows to convert the RS485 signal to Wi-Fi, through a simple and intuitive interface.

### PW MOBILE



A new communication system that allows you to transfer data using mobile 4G network.

## TECHNICAL DATA

CODE	DESCRIPTION
F13292000	PW 14 - USB CONVERTER
F1226201A	KIT KEY READER
F23525000	MANAGER KEY USB TYPE C
F1249600A	MANAGER KEY
F1271005A	PW-LAN
F1271004B	PW-WIFI
F1271015A	PW MOBILE 4G



# CUBE MC

## FEATURES

- MULTI-USER MANAGEMENT
- ALL-IN-ONE EQUIPMENT
- COMPACT DESIGN
- COMPATIBLE WITH SSM AGILIS SOFTWARE
- SUCTION FILTER
- IP55

The PIUSI CUBE MC is the upgraded version of the world famous CUBE dispenser equipped with an electronic panel able to manage up to 250 users and 255 transactions. The sturdy structure includes a self-priming vane pump, built-in bypass, automatic nozzle, and integrated nozzle holder with start/stop pump lever.

### PERFORMANCE

UP TO  
**70 L/MIN**

FLOW RATE

**AC/DC**

VOLTAGE

**± 0,5%**

ACCURACY

UP TO  
**250**

USERS

Upgrade your MC hardware to B.SMART with KIT UPGRADE 1.0/2018.



CUBE 70 MC WITH PEDESTAL (OPTIONAL)



CUBE 70 MC



### PACKAGING

CODE	WEIGHT		PACKAGING			N. BOXES / EUROPALLET	
	KG	LBS	MM	INCH	PCS/BOX	✈	🚚
FO059415D	25	55	400X400X460	-	1	12	24
FO059400E	25	55	400X400X460	-	1	12	24
FO059413D	25	55	400X400X460	-	1	12	24





FILTRATION



TANK MONITORING



HOSE REEL



ACCESSORIES



MERCHANDISE

# PIUSI

INDEX

B

ANY BIODIESEL

A

AIR

A

ANTIFREEZE

Ad

AdBlue®

B

BIODIESEL

D

DIESEL

F

FOOD

G

GASOLINE

G

GREASE

K

KEROSENE

O

OIL

W

WATER

W

WINDSCREEN

## CHART

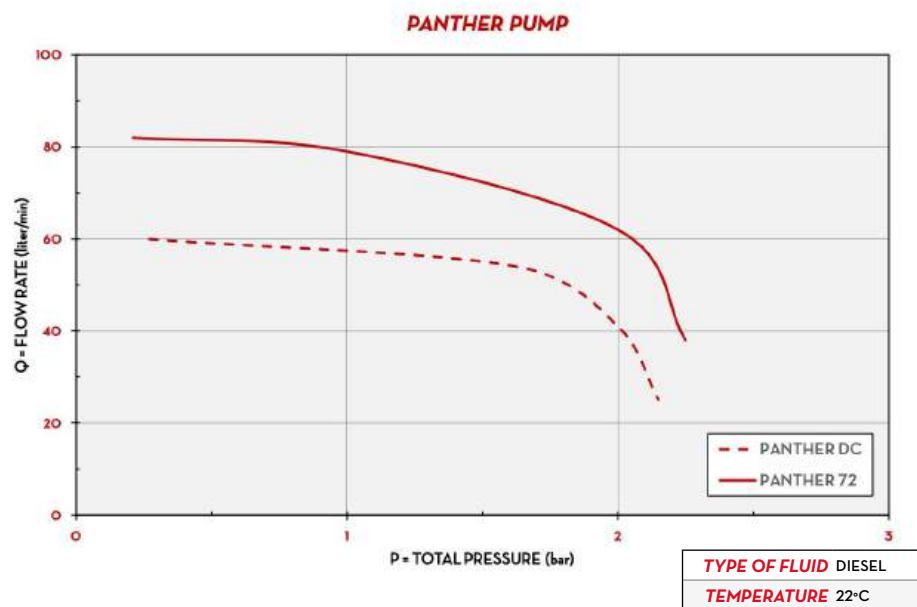

## DIMENSIONS

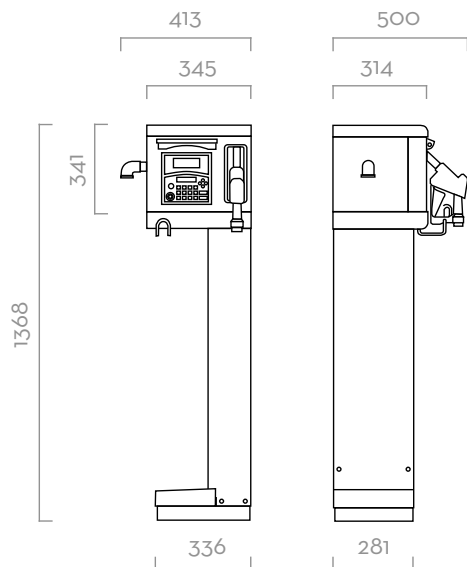

Dimensions expressed in millimeters

## IN THE BOX

- CUBE MC DISPENSER
- AUTOMATIC NOZZLE
- DELIVERY HOSE
- INSTRUCTION MANUAL

## DETAILS



SHUTTER



DRIVER KEY (not included)



DATA TRANSFER AGILIS



SSM AGILIS SOFTWARE

## MATERIALS

- **PUMPS:**  
PANTHER AC  
PANTHER DC
- **METER:**  
K600/3
- **NOZZLE:**  
AUTOMATIC NOZZLE

## TECHNICAL DATA

CODE	DESCRIPTION	FLUIDS TYPE	FLOW RATE		VOLTAGE			PUMP	METER	NOZZLE	FILTER	INLET	HOSE		PC		USERS
			L/MIN	GPM	AC V./HZ	DC VOLT	POWER WATT						AMP. MAX.	TYPE	TYPE	TYPE	
FO059415D	CUBE 70 MC 230V/50HZ 250U AGILIS	D	70	18	230/50	800	3.9	PANTH 72	K600	A60	NO	1"	4M	1"	YES	250	
FO059400E	CUBE 70 MC 230V/50HZ 80U AGILIS	D	70	18	230/50	800	3.9	PANTH 72	K600	A60	NO	1"	4M	1"	YES	80	
FO059413D	CUBE 70 MC 12V 80U AGILIS	D	60	15	12	420	35	PANTH DC	K600	A60	NO	1"	4M	1"	YES	80	

UPON REQUEST IT IS AVAILABLE WITH DIFFERENT VOLTAGES AND 60 HZ FREQUENCY



# SELF SERVICE MC

## FEATURES

- MULTI-USER MANAGEMENT
- WATER CAPTOR FILTER
- ALL-IN-ONE EQUIPMENT
- COMPACT DESIGN
- COMPATIBLE WITH SSM AGILIS SOFTWARE
- IP55

The PIUSI SELF SERVICE MC is a complete device suitable to fit all diesel dispensing needs. With its sturdy structure, this dispenser is equipped with a high capacity vane pump, built-in bypass, automatic nozzle, water captor filter and electronic panel able to manage up to 80 users and 255 transactions.

### PERFORMANCE

UP TO <b>90 L/MIN</b>	<b>AC</b> CONTINUOUS DUTY
FLOW RATE	POWER
<b>± 0,5%</b>	UP TO <b>250</b>
ACCURACY	USERS

Upgrade your MC hardware to B.SMART with KIT UPGRADE 1.0/2018.



SELF SERVICE MC



ELECTRONIC METER INTEGRATED



### PACKAGING

CODE	WEIGHT		PACKAGING			N. BOXES / EUROPALLET	
	KG	LBS	MM	INCH	PCS/BOX		
<b>COLUMN VERSION</b>							
FO073801E	67	148	1478X488X400	-	1	6	4
FO074101E	75	165	1478X488X400	-	1	6	4
<b>TANK VERSION</b>							
FO0738BOE	57	126	1080X488X400	-	1	6	4
FO0741BOE	65	143	1080X488X400	-	1	6	4



FILTRATION



TANK MONITORING



HOSE REEL



ACCESSORIES



MERCHANDISE

# PIUSI

INDEX

IS

ANY BIODIESEL

A

AIR

A

ANTIFREEZE

Ad

AdBlue®

B

BIODIESEL

D

DIESEL

F

FOOD

G

GASOLINE

G

GREASE

K

KEROSENE

O

OIL

W

WATER

W

WINDSCREEN

## CHART

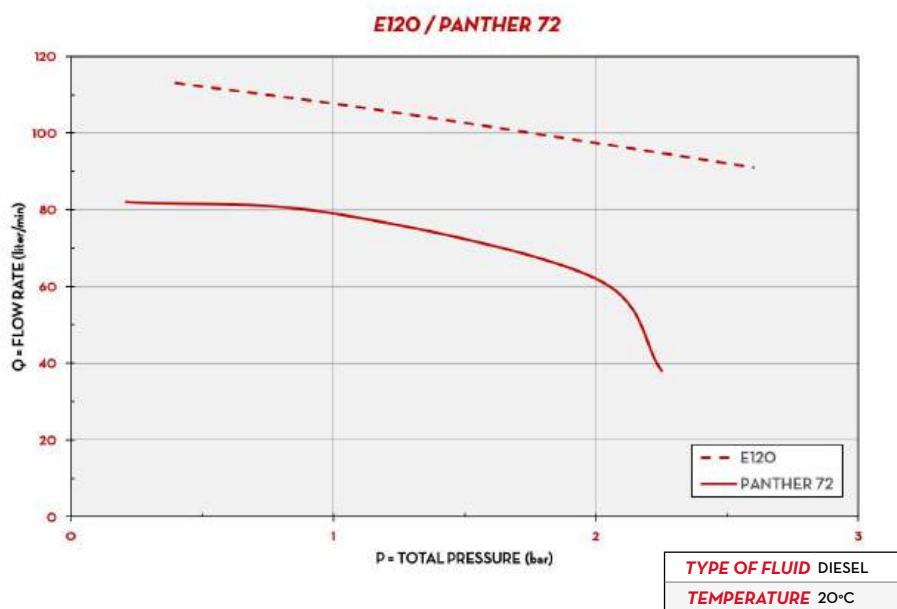

## DIMENSIONS

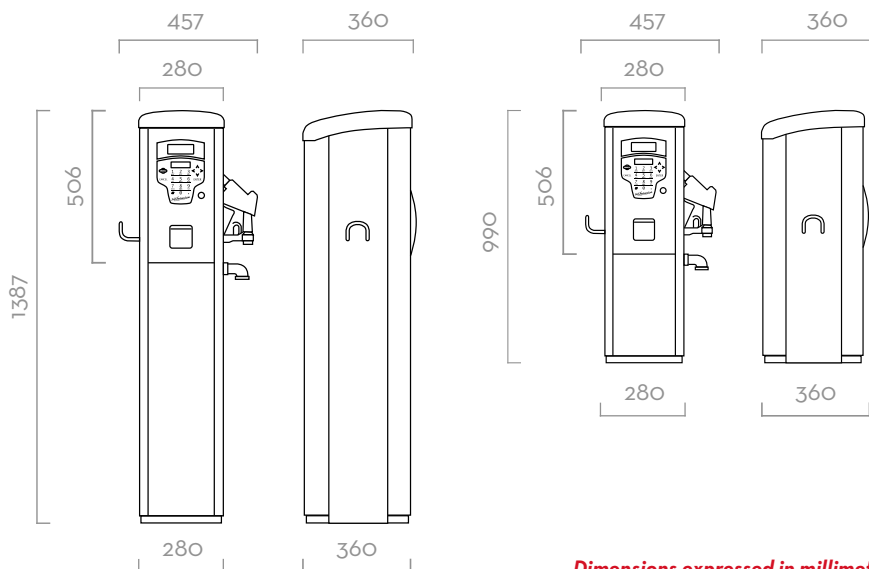

Dimensions expressed in millimeters

## IN THE BOX

- SELF SERVICE MC DISPENSER
- DELIVERY HOSE
- AUTOMATIC NOZZLE
- INSTRUCTION MANUAL

## DETAILS



TANK VERSION AVAILABLE



WATER CAPTOR FILTER



DRIVER KEY (not included)



SSM AGILIS SOFTWARE

## MATERIALS

- PUMPS:  
PANTHER 72 / E120
- METER:  
K600/3
- NOZZLE:  
AUTOMATIC NOZZLE
- FILTER:  
WATER CAPTOR

## TECHNICAL DATA

CODE	DESCRIPTION	FLUIDS TYPE	FLOW RATE		VOLTAGE			PUMP	METER	NOZZLE	FILTER		INLET	HOSE LENGTH	PC
			L/MIN	GPM	AC V/HZ	DC VOLT	POWER WATT				AMP. MAX.	H2O FILTER			

### COLUMN VERSIONS

FO073801E	SELF SERVICE 70 MC 230V/50HZ AGILIS	D	70	18	230/50	800	3.9	PANTH 72	K600	A80	SI	30µ	1" 1/2	4	SI
FO074101E	SELF SERVICE 100 MC 230V/50HZ AGILIS	D	90	24	230/50	1100	5.5	E 120	K600	A120	SI	30µ	1" 1/2	4	SI

### TANK VERSIONS

FO0738BOE	SELF SERVICE TANK 70MC 230V AGILIS	D	70	18	230/50	800	3.9	PANTH 72	K600	A80	NO	-	1" 1/2	4	SI
FO0741BOE	SELF SERVICE TANK100MC 230V AGILIS	D	90	24	230/50	1100	5,5	E 120	K600	A120	NO	-	1" 1/2	4	SI

UPON REQUEST IT IS AVAILABLE WITH DIFFERENT VOLTAGES AND 60 HZ FREQUENCY



FUEL MANAGEMENT SYSTEMS



DISPENSERS



KITS



PUMPS



METERS



NOZZLES

# MCBOX

## FEATURES

- ACCESS CONTROL
- SUITABLE FOR ANY PUMP
- PULSE METER INPUT
- EASY TO INSTALL
- MULTI USERS
- COMPATIBLE WITH SSM AGILIS SOFTWARE

The PIUSI MCBOX is a practical electronic multi-user control panel that allows to manage and control an existing pump, pulse meter and nozzle. Integrated with the SELF SERVICE MANAGEMENT AGILIS, it grants the possibility to download all the transactions.

### PERFORMANCE

UP TO  
**250**

USERS

**AC/DC**  
VOLTAGE

POWER



MCBOX



### PACKAGING

CODE	WEIGHT		PACKAGING		
	KG	LBS	MM	INCH	PCS/BOX
F1398000D	5	11	300X300X180	11,8X11,8X7	1
F1398005C	5	11	300X300X180	11,8X11,8X7	1
F13980130	5	11	300X300X180	11,8X11,8X7	1



FILTRATION



TANK MONITORING



HOSE REEL



ACCESSORIES



MERCHANDISE

## INDEX

- B ANY BIODIESEL
- A AIR
- A ANTIFREEZE
- Ad AdBlue®
- B BIODIESEL
- D DIESEL
- F FOOD
- G GASOLINE
- G GREASE
- K KEROSENE
- O OIL
- W WATER
- W WINDSCREEN

### CONNECTION SCHEME

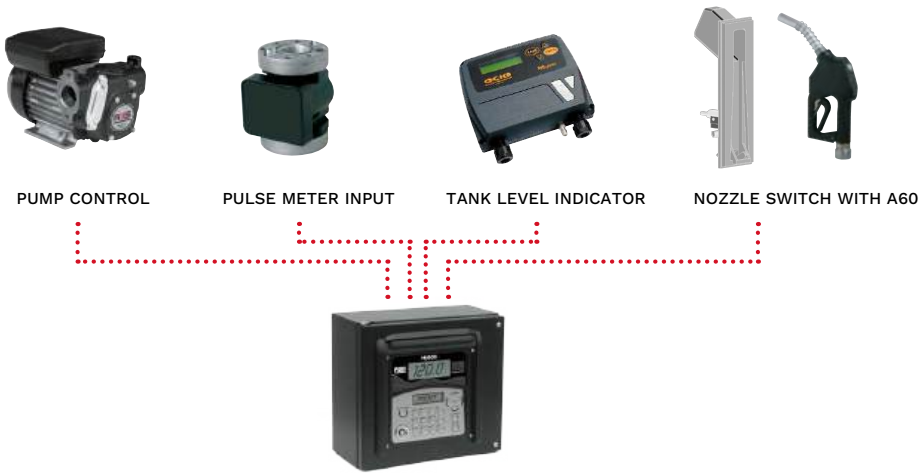

### IN THE BOX

- MCBOX UNIT
- INSTRUCTION MANUAL

### DETAILS



### DIMENSIONS

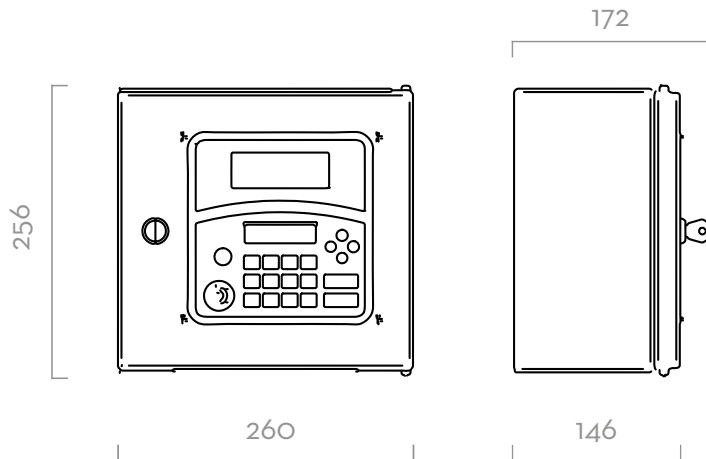

Dimensions expressed in millimeters

### TECHNICAL DATA

CODE	DESCRIPTION	FLUIDS TYPE	USERS	VOLTAGE			SSM AGILIS SOFTWARE
				AC V./HZ	POWER WATT	AMP. MAX. (load motor)	
F139800OD	MCBOX 100-240V 80U AGILIS	<span style="background-color: #add8e6; border-radius: 50%; padding: 1px;">A</span> <span style="background-color: #add8e6; border-radius: 50%; padding: 1px;">Ad</span> <span style="background-color: #90ee90; border-radius: 50%; padding: 1px;">B</span> <span style="background-color: #32cd32; border-radius: 50%; padding: 1px;">D</span> <span style="background-color: #9932cc; border-radius: 50%; padding: 1px;">F</span> <span style="background-color: #e91e63; border-radius: 50%; padding: 1px;">G</span> <span style="background-color: #808080; border-radius: 50%; padding: 1px;">G</span> <span style="background-color: #008000; border-radius: 50%; padding: 1px;">K</span> <span style="background-color: #ffc107; border-radius: 50%; padding: 1px;">O</span> <span style="background-color: #17a2b8; border-radius: 50%; padding: 1px;">W</span> <span style="background-color: #ffc107; border-radius: 50%; padding: 1px;">W</span>	250	100/240	5	15	OPTIONAL
F1398005C	MCBOX 100-240V 250U AGILIS	<span style="background-color: #add8e6; border-radius: 50%; padding: 1px;">A</span> <span style="background-color: #add8e6; border-radius: 50%; padding: 1px;">Ad</span> <span style="background-color: #90ee90; border-radius: 50%; padding: 1px;">B</span> <span style="background-color: #32cd32; border-radius: 50%; padding: 1px;">D</span> <span style="background-color: #9932cc; border-radius: 50%; padding: 1px;">F</span> <span style="background-color: #e91e63; border-radius: 50%; padding: 1px;">G</span> <span style="background-color: #808080; border-radius: 50%; padding: 1px;">G</span> <span style="background-color: #008000; border-radius: 50%; padding: 1px;">K</span> <span style="background-color: #ffc107; border-radius: 50%; padding: 1px;">O</span> <span style="background-color: #17a2b8; border-radius: 50%; padding: 1px;">W</span> <span style="background-color: #ffc107; border-radius: 50%; padding: 1px;">W</span>	80	100/240	5	15	OPTIONAL
F13980130	MCBOX 12V/24V 250U AGILIS	<span style="background-color: #add8e6; border-radius: 50%; padding: 1px;">A</span> <span style="background-color: #add8e6; border-radius: 50%; padding: 1px;">Ad</span> <span style="background-color: #90ee90; border-radius: 50%; padding: 1px;">B</span> <span style="background-color: #32cd32; border-radius: 50%; padding: 1px;">D</span> <span style="background-color: #9932cc; border-radius: 50%; padding: 1px;">F</span> <span style="background-color: #e91e63; border-radius: 50%; padding: 1px;">G</span> <span style="background-color: #808080; border-radius: 50%; padding: 1px;">G</span> <span style="background-color: #008000; border-radius: 50%; padding: 1px;">K</span> <span style="background-color: #ffc107; border-radius: 50%; padding: 1px;">O</span> <span style="background-color: #17a2b8; border-radius: 50%; padding: 1px;">W</span> <span style="background-color: #ffc107; border-radius: 50%; padding: 1px;">W</span>	250	12/24	5	50/25	OPTIONAL



# FUEL MANAGEMENT SYSTEMS

## ACCESSORIES

### B.SMART

CUBE B.SMART	CODE	DESCRIPTION	
	F22500000	DRIVER ACCESS (X10)	
	FO0770D20	DRIVER ACCESS (X50)	
	F1590400A	USER KEY (YELLOW KEY: 10PCS)	
	F1270800C	PEDESTAL	
	F1273700A	KIT WALL SUPPORT	

SELF SERVICE MC B.SMART	CODE	DESCRIPTION	
	F22500000	DRIVER ACCESS (X10)	
	FO0770D20	DRIVER ACCESS (X50)	
	F1590400A	USER KEY (YELLOW KEY: 10PCS)	

MCBOX B.SMART	CODE	DESCRIPTION	
	F22500000	DRIVER ACCESS (X10)	
	FO0770D20	DRIVER ACCESS (X50)	
	F1590400A	USER KEY (YELLOW KEY: 10PCS)	
	F1270800C	PEDESTAL	
	F1273700A	KIT WALL SUPPORT	
	F17121000	LEVEL PROBE FOR ACCESS 85	

### SSM2.0

CUBE MC 2.0	CODE	DESCRIPTION	
	F0893000A	KIT QUICK COUPLING 2IN X 1IN	
	F1270800C	KIT PEDESTAL CUBE BLACK	
	F1273700A	WALL KIT CUBE	
	F1273800A	KIT PADLOCK CUBE MC	
	F1590400A	KIT DRIVER KEY YELLOW (10PCS)	
	F17163000	2" BSP DRUM CONNECTOR WITH VALVE	
	F17299000	KIT VEHICLE KEY BLUE (10PCS)	

SELF SERVICE MC 2.0	CODE	DESCRIPTION	
	F1590400A	KIT DRIVER KEY YELLOW (10PCS)	
	F17299000	KIT VEHICLE KEY BLUE (10PCS)	

SELF SERVICE FM 2.0	CODE	DESCRIPTION	
	F1590400A	KIT DRIVER KEY YELLOW (10PCS)	
	F17299000	KIT VEHICLE KEY BLUE (10PCS)	

## SSM2.0

MCBOX 2.0	CODE	DESCRIPTION
	F1270800C	KIT PEDESTAL CUBE BLACK
	F1590400A	KIT DRIVER KEY YELLOW (10PCS)
	F17299000	KIT VEHICLE KEY BLUE (10PCS)
	F17121000	LEVEL PROBE FOR ACCESS 85



## SSM AGILIS

CUBE MC	CODE	DESCRIPTION
	F0893000A	KIT QUICK COUPLING 2IN X 1IN
	F1249600A	MANAGER KEY
	F1270800C	KIT PEDESTAL CUBE BLACK
	F1273700A	WALL KIT CUBE
	F1273800A	KIT PADLOCK CUBE MC
	F1590400A	KIT DRIVER KEY YELLOW (10PCS)
	F17163000	2" BSP DRUM CONNECTOR WITH VALVE

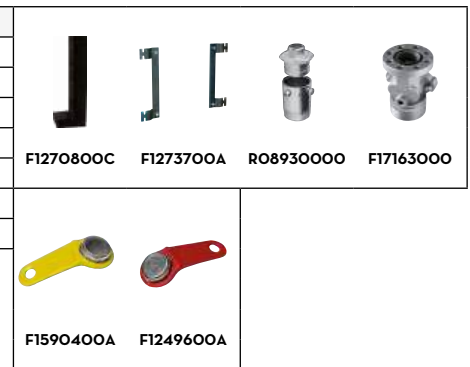

SELF SERVICE MC	CODE	DESCRIPTION
	F1249600A	MANAGER KEY
	F1590400A	KIT DRIVER KEY YELLOW (10PCS)



MCBOX	CODE	DESCRIPTION
	F1249600A	MANAGER KEY
	F1270800C	KIT PEDESTAL CUBE BLACK
	F1590400A	KIT DRIVER KEY YELLOW (10PCS)
	F1623900B	NOZZLE HOLDER SS+CABLED SWITCH FM/MC
	F17121000	LEVEL PROBE FOR ACCESS 85







# **DISPENSERS**

A solid red triangle is positioned in the bottom right corner of the page, pointing towards the top left. It is a simple, flat-colored geometric shape.



FUEL MANAGEMENT SYSTEMS



DISPENSERS



KITS



PUMPS



METERS



NOZZLES

# CUBE

## FEATURES

- STURDY STRUCTURE
- MECHANICAL METER
- INDUCTION THERMAL-PROTECTED MOTOR
- OVERLOAD PROTECTION
- BUILT-IN MESH FILTER
- IP 55

The PIUSI CUBE is a range of mechanical fuel transfer dispenser for non-commercial use, composed of a self-priming vane pump fitted with integrated bypass valve, automatic nozzle with swivel connection and integrated nozzle holder with start/stop pump lever. Its versatility allows different applications: on walls, on tanks, on cisterns, on drums or stand-alone (with the optional pedestal).

### PERFORMANCE

UP TO  
**90 L/MIN**

FLOW RATE

**AC/DC**  
VOLTAGE

POWER

**±1%**

ACCURACY



CUBE 56 WITH FILTER



CUBE 56 WITH PEDESTAL (OPTIONAL)

### PACKAGING

CODE	WEIGHT		PACKAGING			N. BOXES / EUROPALLET	
	KG	LBS	MM	INCH	PCS/BOX	✕	🚚
FO0575400	22	46	400X400X460	-	1	12	24
00057500C	21	46	400X400X460	-	1	12	24
FO057600C	21	46	400X400X460	-	1	12	24
FO057700C	21	46	400X400X460	-	1	12	24
FO0591200	22	48	400X400X460	-	1	12	24
FO059100A	21	46	400X400X460	-	1	12	24
FO059111A	21	46	400X400X460	-	1	12	24
FO0592000	22	46	400X400X460	-	1	12	24



FILTRATION



TANK MONITORING



HOSE REEL



ACCESSORIES



MERCHANDISE

# PIUSI

INDEX

B

ANY BIODIESEL

A

AIR

A

ANTIFREEZE

Ad

AdBlue®

B

BIODIESEL

D

DIESEL

F

FOOD

G

GASOLINE

G

GREASE

K

KEROSENE

O

OIL

W

WATER

W

WINDSCREEN

## CHART

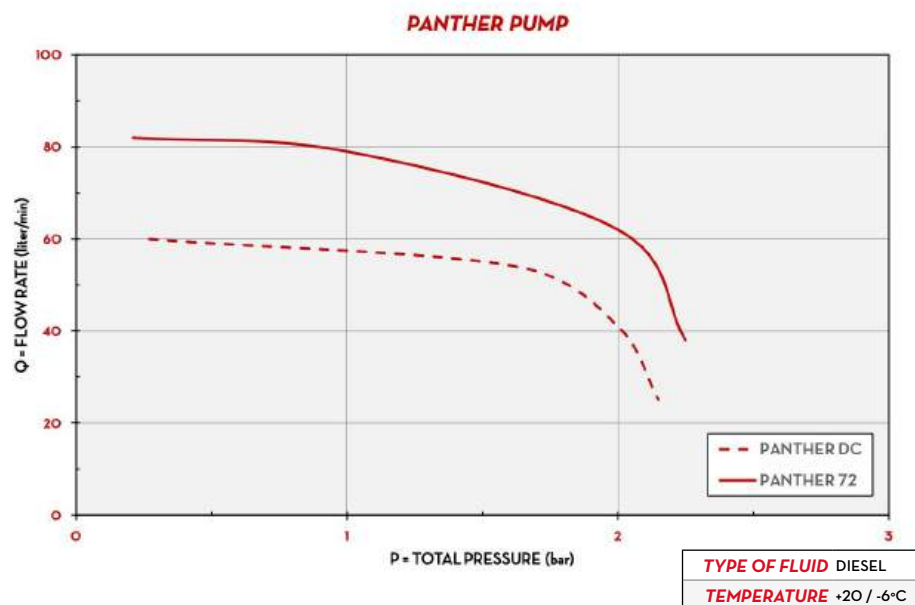

## IN THE BOX

- CUBE DISPENSER
- AUTOMATIC NOZZLE
- DELIVERY HOSE
- INSTRUCTION MANUAL

## DETAILS



NUTATING DISK METER



K33/K44

## DIMENSIONS

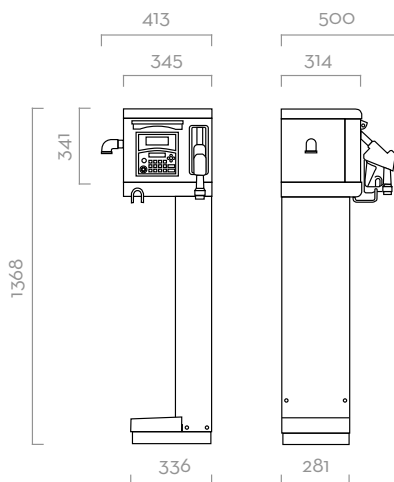

Dimensions expressed in millimeters

## COMPONENTS

- **PUMPS:**  
PANTHER AC  
PANTHER DC
- **METER:**  
K33 / K44
- **NOZZLE:**  
AUTOMATIC NOZZLE

## TECHNICAL DATA

CODE	DESCRIPTION	FLUIDS TYPE	FLOW RATE		VOLTAGE			PUMP	METER	NOZZLE	FILTER		INLET	HOSE	
			L/MIN	GPM	AC V/ HZ	DC VOLT	POWER WATT				AMP. MAX.	H2O FILTER		FILTERING CAPACITY	BSP
FO0575400	CUBE 56/33 + FILTER	D	56	15	230/50	350	3	PANTH 56	K33	A60	YES	30 µ	1"	6M	3/4"
OO057500C	CUBE 56/33	D	56	15	230/50	350	3	PANTH 56	K33	A60	NO	-	1"	4M	3/4"
FO057600C	CUBE 56 DC 12V	D	56	15	12	300	35	PANTH DC	K33	A60	NO	-	1"	4M	1"
FO057700C	CUBE 70 DC 24V	D	70	18	24	420	25	PANTH DC	K33	A60	NO	-	1"	4M	3/4"
FO0591200	CUBE 70/33 + FILTER	D	70	18	230/50	500	4,2	PANTH 72	K33	A60	YES	30 µ	1"	6M	1"
FO059100A	CUBE 70/33	D	70	18	230/50	500	4,2	PANTH 72	K33	A60	NO	-	1"	4M	1"
FO059111A	CUBE 70/44 PULSER	D	70	18	230/50	500	4,2	PANTH 72	K44	A60	NO	-	1"	4M	1"
FO0592000*	CUBE 90/44	D	90	23,8	230/50	700	4,9	PANTH 90	K44	A120	NO	-	1"	4M	1"

UPON REQUEST IT IS AVAILABLE WITH DIFFERENT VOLTAGES AND 50/60 HZ FREQUENCY  
\*DUTY CYCLE 30MIN ON/OFF



FUEL MANAGEMENT SYSTEMS



DISPENSERS



KITS



PUMPS



METERS



NOZZLES

# SELF SERVICE K44

## FEATURES

- ALL-IN-ONE EQUIPMENT
- WATER CAPTOR FILTER
- COMPACT DESIGN
- IP55

The PIUSI SELF SERVICE K44 is a fuel dispenser unit equipped with a high capacity vane pump, built-in bypass valve and mechanical K44 meter. Particularly suitable for all the needs of high-flow rate diesel dispensing, it guarantees that the dispensed product is free of water and impurities thanks to the integrated filter (column version). Available both as column or tank version, it features a front door for easy maintenance.

### PERFORMANCE

UP TO

**90 L/MIN**

FLOW RATE

**AC**

**CONTINUOUS DUTY**

POWER

**±1%**

ACCURACY



MECHANICAL METER INTEGRATED



SELF SERVICE K44

### PACKAGING

CODE	WEIGHT		PACKAGING			N. BOXES / EUROPALET	
	KG	LBS	MM	INCH	PCS/BOX	✕	

#### COLUMN VERSIONS

FO073701B	67	148	1478X488X400	-	1	6	4
FO074001B	75	165	1478X488X400	-	1	6	4
FO074002A	75	165	1478X488X400	-	1	6	4

#### TANK VERSIONS

FO0737BOB	57	126	1080X488X400	-	1	6	4
FO0737B2B	57	126	1080X488X400	-	1	6	4



FILTRATION



TANK MONITORING



HOSE REEL



ACCESSORIES



MERCHANDISE

# PIUSI

INDEX

B

ANY BIODIESEL

A

AIR

A

ANTIFREEZE

Ad

AdBlue®

B

BIODIESEL

D

DIESEL

F

FOOD

G

GASOLINE

G

GREASE

K

KEROSENE

O

OIL

W

WATER

W

WINDSCREEN

### CHART

#### PANTHER 72 / E120

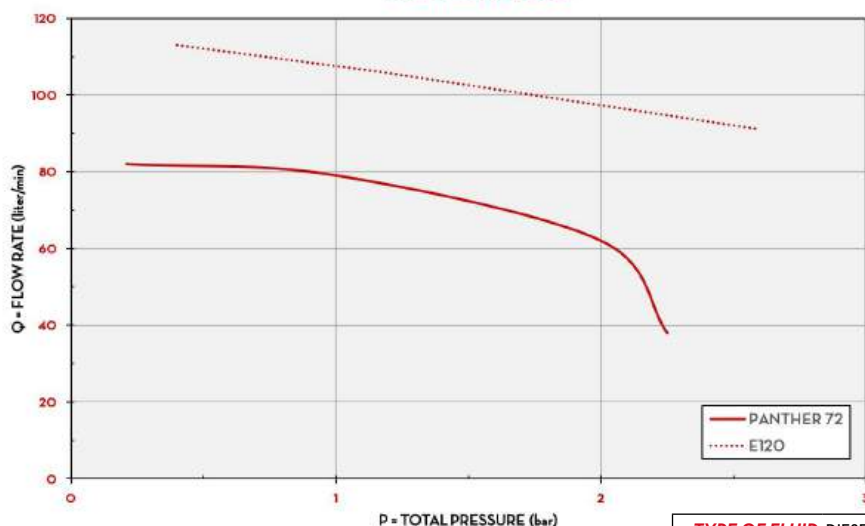

TYPE OF FLUID DIESEL  
TEMPERATURE 20/23 °C

### IN THE BOX

- SELF SERVICE K44 DISPENSER
- DELIVERY HOSE
- AUTOMATIC NOZZLE
- INSTRUCTION MANUAL

### DETAILS



K44



INTEGRATED FILTER

### DIMENSIONS

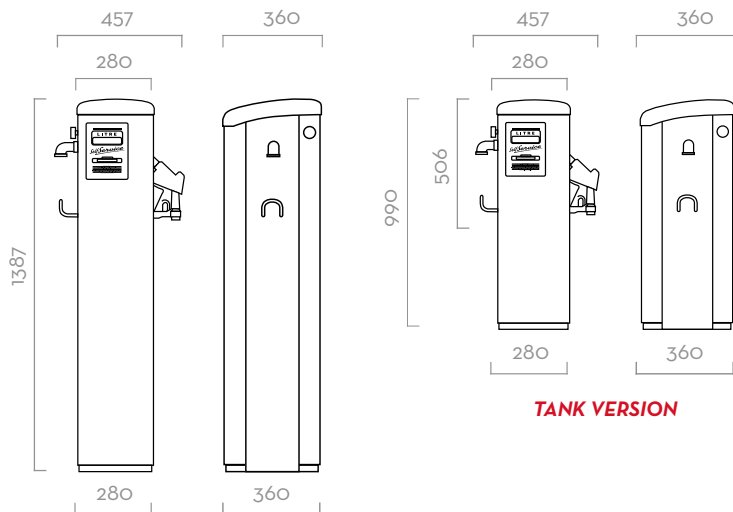

COLUMN VERSION

TANK VERSION

Dimensions expressed in millimeters

### COMPONENTS

- PUMPS:  
PANTHER AC / E120
- METERS  
K44
- NOZZLE:  
AUTOMATIC NOZZLE
- FILTER:  
WATER CAPTOR

### TECHNICAL DATA







CODE	DESCRIPTION	FLUIDS TYPE	FLOW RATE		VOLTAGE			PUMP TYPE	METER TYPE	NOZZLE TYPE	FILTER		INLET BSP	HOSE LENGTH METERS	PC CONNECTION
			L/MIN	GPM	AC V./HZ	DC VOLT	POWER WATT				AMP. MAX.	H2O FILTER			
<b>COLUMN VERSIONS</b>															
FO073701B	SELF SERVICE 70 K44	D	70	18	230/50	550	3,3	PANTH 72	K44	A80	YES	30µ	1" 1/2	4	NO
FO074001B	SELF SERVICE 100 K44	D	90	24	230/50	1150	5,7	E 120	K44	A120	YES	30µ	1" 1/2	4	NO
FO074002A	SELF SERVICE 100 K44 PULSER	D	90	24	230/50	1150	5,7	E 120	K44 P	A120	YES	30µ	1" 1/2	4	NO
<b>TANK VERSIONS</b>															
FO0737B0B	SELF SERVICE 70 K44 TANK	D	70	18	230/50	550	3,3	PANTH 72	K44	A80	NO	-	1" 1/2	4	NO
FO0737B2B	SELF SERVICE 70 K44 TANK PULSER	D	70	18	230/50	550	3,3	PANTH 72	K44 P	A80	NO	-	1" 1/2	4	NO

UPON REQUEST IT IS AVAILABLE WITH DIFFERENT VOLTAGES AND 60 HZ FREQUENCY



# DISPENSERS ACCESSORIES

## MECHANICAL DISPENSER

CUBE	CODE	DESCRIPTION					
	FO893000A	KIT QUICK COUPLING 2IN X 1IN	    	F1270800C	F1273700A	R08930000	R12738000
	F1270800C	KIT PEDESTAL CUBE BLACK					
	F1273700A	WALL KIT CUBE					
	F1273800A	KIT PADLOCK CUBE MC					
	F17163000	2" BSP DRUM CONNECTOR WITH VALVE					
							
			F17163000				







**KITS**





FUEL MANAGEMENT SYSTEMS



DISPENSERS



KITS



PUMPS



METERS



NOZZLES

# EX50 DRUM

## FEATURES

- STURDY STRUCTURE
- FLANGED COMPONENTS
- ANTI-NOISE FILTER
- THERMAL PROTECTION
- BUILT-IN BYPASS VALVE
- SUCTION PIPE WITH INTEGRATED FILTER
- UL LISTED VERSION AVAILABLE

The PIUSI EX50 DRUM is a complete pump transfer kit expressly engineered for ATEX/IECEx areas. This system is composed of a high-efficiency pump, manual or automatic nozzle and a telescopic suction hose. Thanks to the flanged components, this transfer set allows users to replace any component without using sealants thus creating maximum versatility and adaptability to any kind of condition. K33 mechanical meter available on request.



PIUSI EX50 DRUM WITH METER AND FILTER



### PERFORMANCE

UP TO  
**50 L/MIN**

FLOW RATE

**1100 MM**

SUCTION PIPE

**±1%**

ACCURACY

**200β/30μ**

FILTERING CAPACITY



EX50 DRUM WITH AUTOMATIC NOZZLE



EX50 DRUM WITH MANUAL NOZZLE

OUR PUMPS COMPLIES WITH THE FOLLOWING MARKING ATEX/IECEx

II	2	G	Ex	d	IIA	T4	Gb
GROUP	CATEGORY	TYPE OF EXPLOSIVE ATMOSPHERE	PERMANENT PREFIX	PROTECTION METHOD	GAS GLASS	TEMPERATURE CLASS	EQUIPMENT PROTECTION LEVEL

### PACKAGING

CODE	WEIGHT		PACKAGING		
	KG	LBS	MM	INCH	PCS/BOX
<b>WITHOUT METER</b>					
FO0372000	10	22	600X400X290	23,6X13,7X11,4	1
FO0372010	10	22	600X400X290	23,6X13,7X11,4	1
FO0372020	7,9	17,4	345X175X225	-	1
<b>WITH METER</b>					
FO037500A	12	22	600X400X290	23,6X13,7X11,4	1
FO037501A	12	22	600X400X290	23,6X13,7X11,4	1



FILTRATION



TANK MONITORING



HOSE REEL



ACCESSORIES



MERCHANDISE

# PIUSI

INDEX

B

ANY BIODIESEL

A

AIR

A

ANTIFREEZE

Ad

AdBlue®

B

BIODIESEL

D

DIESEL

F

FOOD

G

GASOLINE

G

GREASE

K

KEROSENE

O

OIL

W

WATER

W

WINDSCREEN

## CHART

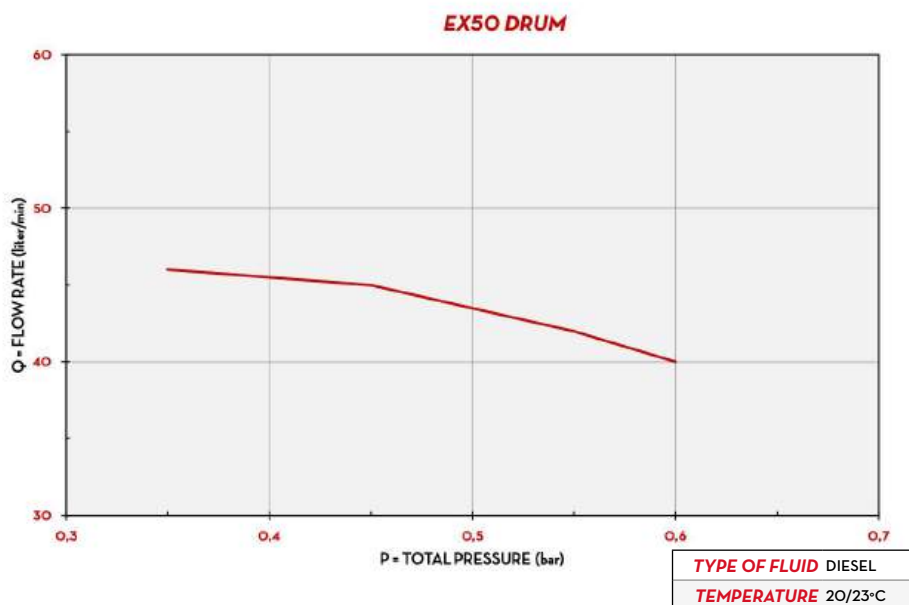

## DIMENSIONS

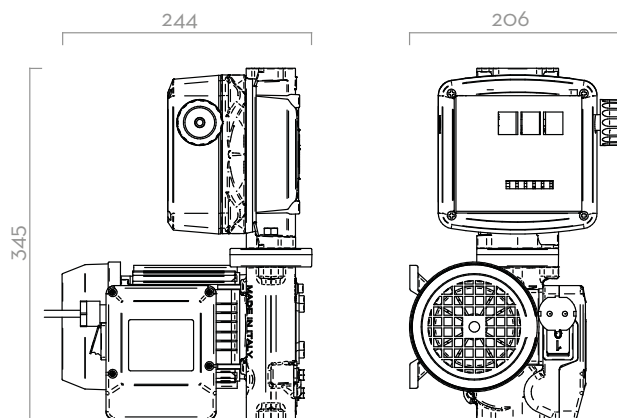

Dimensions expressed in millimeters

## IN THE BOX

- EX50 PUMP
- TELESCOPIC SUCTION PIPE
- DELIVERY HOSE
- WATER CAPTOR FILTER
- A60 ATEX NOZZLE
- 2" CONNECTOR
- K33 ATEX METER (ON SELECTED VERSION)
- INSTRUCTION MANUAL

## DETAILS



## COMPONENTS

- **PUMP:**  
EX50
- **METER:**  
K33 ATEX
- **NOZZLE:**  
A60 ATEX  
SELF3000
- **FILTER:**  
WATER CAPTOR

## TECHNICAL DATA

CODE	DESCRIPTION	FLUIDS TYPE	FLOW RATE		VOLTAGE			METER	NOZZLE	FILTER	INLET	HOSE	
			L/MIN	GPM	AC V/ HZ	DC VOLT	POWER WATT					AMP. MAX.	BSP
<b>WITHOUT METER</b>													
FO0372000	DRUM EX50 12V DC ATEX + MAN. NOZZLE	B G K	50	13	12	250	21	-	SELF3000	YES	1"	4	3/4"
FO0372010	DRUM EX50 12V DC ATEX + AUT. NOZZLE	B G K	50	13	12	250	21	-	A60	YES	1"	4	3/4"
FO0372020	KIT DRUM EX50 12V DC ATEX	B G K	50	13	12	250	21	-	NO	NO	1"	-	-
<b>WITH METER</b>													
FO037500A	DRUM EX50 12V DC K33 ATEX + MAN. NOZZLE	B G K	50	13	12	250	21	K33	SELF3000	YES	1"	4	3/4"
FO037501A	DRUM EX50 12V DC K33 ATEX + AUT. NOZZLE	B G K	50	13	12	250	21	K33	A60	YES	1"	4	3/4"

( ) UPON REQUEST IT IS AVAILABLE WITH DIFFERENT VOLTAGES AND 60 HZ FREQUENCY. COMPATIBLE FLUIDS: DIESEL, KEROSENE, PETROL, PETROL ALCOHOL MIXED MAX 15%, AVGAS 100/100LL (ONLY PUMP&METER), JET A/A1 (ONLY PUMP&METER), ASPEN 2/4



FUEL MANAGEMENT SYSTEMS



DISPENSERS



KITS



PUMPS



METERS



NOZZLES

# EX100 DRUM

## FEATURES

- CONTINUOUS DUTY
- THERMAL PROTECTION
- SUCTION UNIT WITH INTEGRATED FILTER
- BUILT-IN BYPASS VALVE
- UL VERSION AVAILABLE

PIUSI EX100 DRUM is the new transfer kit for flammable fluids that is characterized by a high flow rate and works with a continuous duty cycle. Simple to use, compact, versatile, it adapts to any working conditions: you can use it wherever you need it most. The PIUSI EX100 DRUM is ATEX certified and complies with the directives on the use of materials in potentially explosive atmospheres.



### PERFORMANCE

UP TO  
**100 L/MIN**

FLOW RATE

**AC**  
VOLTAGE

POWER



EX100 DRUM /A140/K150/5MT



EX100 DRUM /A140/5MT



OUR PUMPS COMPLIES WITH THE FOLLOWING MARKING ATEX/IECEx

II	2	G	Ex	d	IIA	T4	Gb
GROUP	CATEGORY	TYPE OF EXPLOSIVE ATMOSPHERE	PERMANENT PREFIX	PROTECTION METHOD	GAS GLASS	TEMPERATURE CLASS	EQUIPMENT PROTECTION LEVEL

### PACKAGING

CODE	WEIGHT		PACKAGING		
	KG	LBS	MM	INCH	PCS/BOX
FO0391010	25	55	240X400X350	10X16X15	1
FO0391020	25	55	240X400X350	10X16X15	1
FO0391310	32	70	400X600X430	16X24X17	1



FILTRATION



TANK MONITORING



HOSE REEL



ACCESSORIES



MERCHANDISE

# PIUSI

INDEX

B

ANY BIODIESEL

A

AIR

A

ANTIFREEZE

Ad

AdBlue®

B

BIODIESEL

D

DIESEL

F

FOOD

G

GASOLINE

G

GREASE

K

KEROSENE

O

OIL

W

WATER

W

WINDSCREEN

## CHART

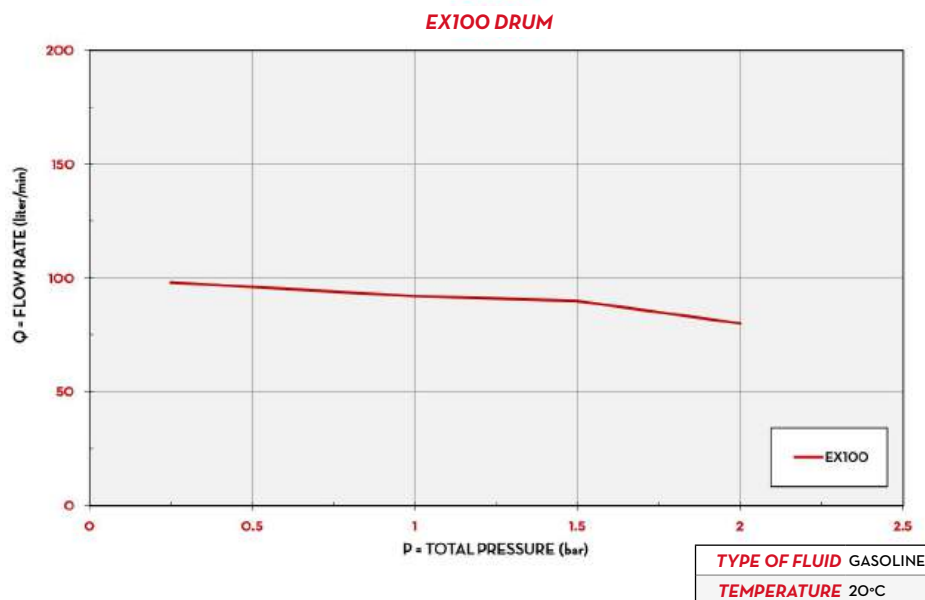

## DIMENSIONS

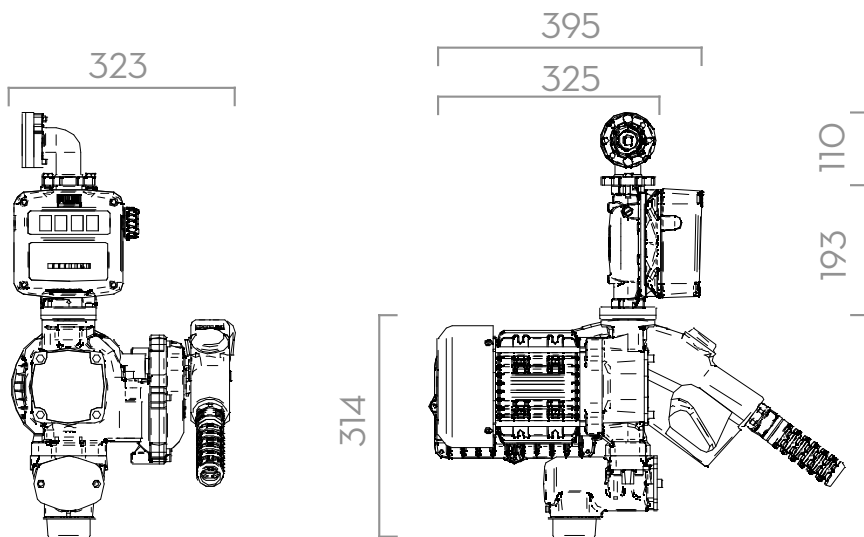

Dimensions expressed in millimeters

## IN THE BOX

- EX100 PUMP
- NOZZLE HOLDER
- 2" TANK CONNECTOR
- 90° FLANGED ELBOW
- K150 ATEX METER (ON SELECTED VERSION)
- A140 ATEX AUTOMATIC NOZZLE (ON SELECTED VERSION)
- DELIVERY HOSE (ON SELECTED VERSION)
- INSTRUCTION MANUAL

## DETAILS



MESH STRAINER



2" TANK CONNECTOR



90° FLANGED ELBOW



BENDING PROTECTION

## COMPONENTS

- PUMP:  
EX100
- METER:  
K150 ATEX
- NOZZLE:  
A140 ATEX

## TECHNICAL DATA

CODE	DESCRIPTION	FLUIDS TYPE	FLOW RATE		VOLTAGE			DUTY CYCLE	CONTINUOUS	INLET	OUTLET	METER	DELIVERY HOSE	BENDING PROTECTION	ULTRA HI-FLOW AUTO NOZZLE
			L/MIN	GPM	AC V./HZ	POWER WATT	AMP. MAX.								
FO0391010	(EX) EX100 DRUM 230V/50HZ (PUMP ONLY)	D G K	100	25	230/50	1035	4,5	YES		2" BSP	1" BSP	-	-	-	-
FO0391020	(EX) EX100 DRUM 230V/60HZ (PUMP ONLY)	D G K	100	25	230/60	874	3,8	YES		2" BSP	1" BSP	-	-	-	-
FO0391310	(EX) EX100 DRUM 230/50 /A140/K150/5MT	D G K	100	25	230/50	1035	4,5	YES		2" BSP	1" BSP	K150	D.25 5MT	YES	A140

( ) UPON REQUEST IT IS AVAILABLE WITH DIFFERENT VOLTAGES AND 60 HZ FREQUENCY. COMPATIBLE FLUIDS: DIESEL, KEROSENE, PETROL, PETROL ALCOHOL MIXED MAX 15%, AVGAS 100/100LL, JET A/A1 - ASPEN 2/4



FUEL MANAGEMENT SYSTEMS



DISPENSERS



KITS



PUMPS



METERS



NOZZLES

# EX140 DRUM

## FEATURES

- CONTINUOUS DUTY
- THERMAL PROTECTION
- SUCTION UNIT WITH INTEGRATED FILTER
- BUILT-IN BYPASS VALVE
- UL VERSION AVAILABLE

The entire new EX line is characterized by a high flow rate that works with a continuous duty cycle, and has been designed to be particularly suitable for Heavy Duty, i.e. for those demanding fleets that need to dispense fuels such as Gasoline, diesel or kerosene quickly.

The PIUSI EX140 DRUM is ATEX certified and complies with the directives on the use of materials in potentially explosive atmospheres.



### PERFORMANCE

UP TO  
**140 L/MIN**

FLOW RATE

**AC**  
VOLTAGE

POWER



EX140 DRUM /A140/K150/5MT

EX140 DRUM /A140/5MT

OUR PUMPS COMPLIES WITH THE FOLLOWING MARKING ATEX/IECEx

II	2	G	Ex	d	IIA	T4	Gb
GROUP	CATEGORY	TYPE OF EXPLOSIVE ATMOSPHERE	PERMANENT PREFIX	PROTECTION METHOD	GAS GLASS	TEMPERATURE CLASS	EQUIPMENT PROTECTION LEVEL

### PACKAGING

CODE	WEIGHT		PACKAGING		
	KG	LBS	MM	INCH	PCS/BOX
FO0396010	25	55	240X400X350	10X16X15	1
FO0396030	25	55	240X400X350	10X16X15	1
FO0396020	25	55	240X400X350	10X16X15	1
FO0396310	32	70	400X600X430	16X24X17	1



FILTRATION



TANK MONITORING



HOSE REEL



ACCESSORIES



MERCHANDISE

# PIUSI

INDEX



ANY BIODIESEL



AIR



ANTIFREEZE



AdBlue®



BIODIESEL



DIESEL



FOOD



GASOLINE



GREASE



KEROSENE



OIL



WATER



WINDSCREEN

## CHART

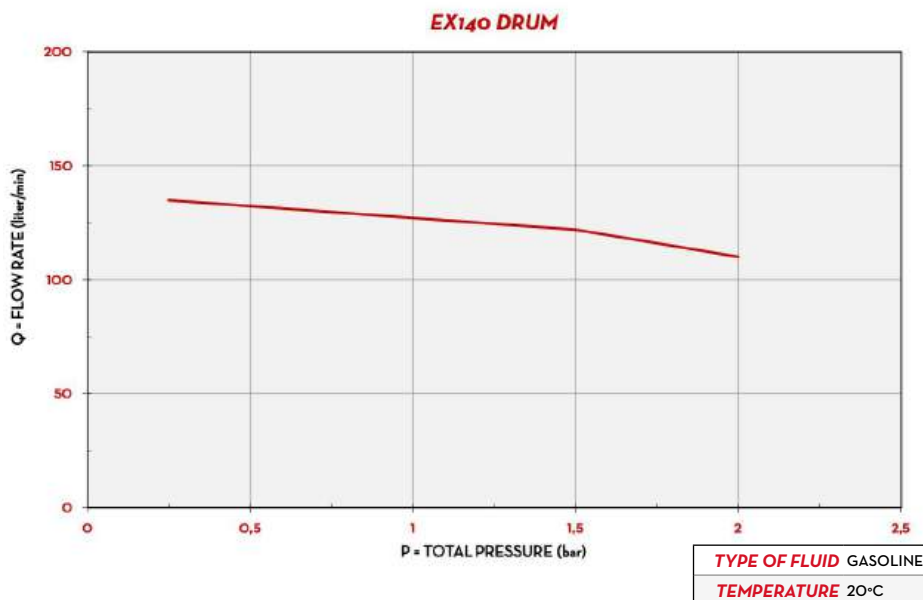

## IN THE BOX

- EX140 PUMP
- NOZZLE HOLDER
- 2" CONNECTOR
- 90° FLANGED ELBOW
- K150 ATEX METER (ON SELECTED VERSION)
- A140 ATEX AUTOMATIC NOZZLE (ON SELECTED VERSION)
- DELIVERY HOSE (ON SELECTED VERSION)
- INSTRUCTION MANUAL

## DETAILS



MESH STRAINER



2" TANK CONNECTOR



90° FLANGED ELBOW



BENDING PROTECTION

## DIMENSIONS

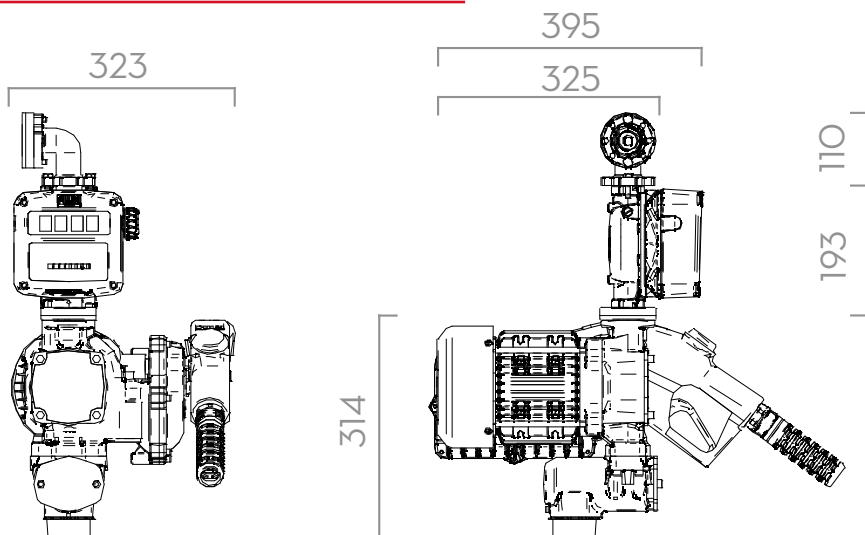

Dimensions expressed in millimeters

## COMPONENTS

- **PUMP:**  
EX140
- **METER:**  
K150 ATEX
- **NOZZLE:**  
A140 ATEX

## TECHNICAL DATA

CODE	DESCRIPTION	FLUIDS TYPE	FLOW RATE		VOLTAGE			DUTY CYCLE	INLET	OUTLET	METER	DELIVERY HOSE	BENDING PROTECTION	ULTRA HI-FLOW AUTO NOZZLE
			L/MIN	GPM	AC V./HZ	POWER WATT	AMP. MAX.							
FO0396010	(EX) EX140 DRUM 230V/50HZ (PUMP ONLY)	D G K	140	37	230/50	1150	5	YES	2" BSP	1" BSP	-	-	-	-
FO0396030	(EX) EX140 DRUM 230V/60HZ (PUMP ONLY)	D G K	140	37	230/60	920	4	YES	2" BSP	1" BSP	-	-	-	-
FO0396020	(EX) EX140 DRUM 250V/50HZ (PUMP ONLY)	D G K	140	37	250/50	1125	4,5	YES	2" BSP	1" BSP	-	-	-	-
FO0396310	(EX) EX140 DRUM 230/50 /A140/K150/5MT	D G K	140	37	230/50	1150	5	YES	2" BSP	1" BSP	K150	D.25 5MT	YES	A140

( ) UPON REQUEST IT IS AVAILABLE WITH DIFFERENT VOLTAGES AND 60 HZ FREQUENCY. COMPATIBLE FLUIDS: DIESEL, KEROSENE, PETROL, PETROL ALCOHOL MIXED MAX 15%, AVGAS 100/100LL, JET A/A1 - ASPEN 2/4



FUEL MANAGEMENT SYSTEMS



DISPENSERS



KITS



PUMPS



METERS



NOZZLES

# DRUM

## FEATURES

- EASY TO INSTALL
- SUITABLE FOR ALL DRUMS
- DIFFERENT PUMPS FOR ANY NEED
- AC/DC VERSIONS

The PIUSI DRUM is a compact fuel transfer unit suitable to be connected on drums thanks to the quick 2" coupling. Available with different pumps, the system is (always) equipped with a telescopic suction hose and the nozzle holder located above the drum, near the pump, for easy, clean and safe operations. K33 mechanical meter available on request.

### PERFORMANCE

UP TO

**80 L/MIN**

FLOW RATE

**AC/DC**

VOLTAGE

POWER

**± 1%**

ACCURACY



DRUM PANTHER 56 K33



DRUM BIPUMP 12V



### PACKAGING

CODE		WEIGHT		PACKAGING		
WITHOUT METER	WITH METER	KG	LBS	MM	INCH	PCS/BOX
OO0271P00	OO0272P00	13,5	29,8	480X370X265	18,3X14,6X10,4	1
OO0273P00	OO0274P00	14,4	31,7	480X370X265	18,3X14,6X10,4	1
-	FO022205A	20,7	45,6	480X370X265	18,3X14,6X10,4	1
-	FO022206A	20,7	45,6	480X370X265	18,3X14,6X10,4	1
-	FO022207A	21,6	47,6	480X370X265	18,3X14,6X10,4	1
-	FO022208A	21,6	47,6	480X370X265	18,3X14,6X10,4	1
-	FO034111C	14,7	31,7	480X370X265	18,3X14,6X10,4	1





FILTRATION



TANK MONITORING



HOSE REEL



ACCESSORIES



MERCHANDISE

# PIUSI

INDEX

B

ANY BIODIESEL

A

AIR

A

ANTIFREEZE

Ad

AdBlue®

B

BIODIESEL

D

DIESEL

F

FOOD

G

GASOLINE

G

GREASE

K

KEROSENE

O

OIL

W

WATER

W

WINDSCREEN

## CHART

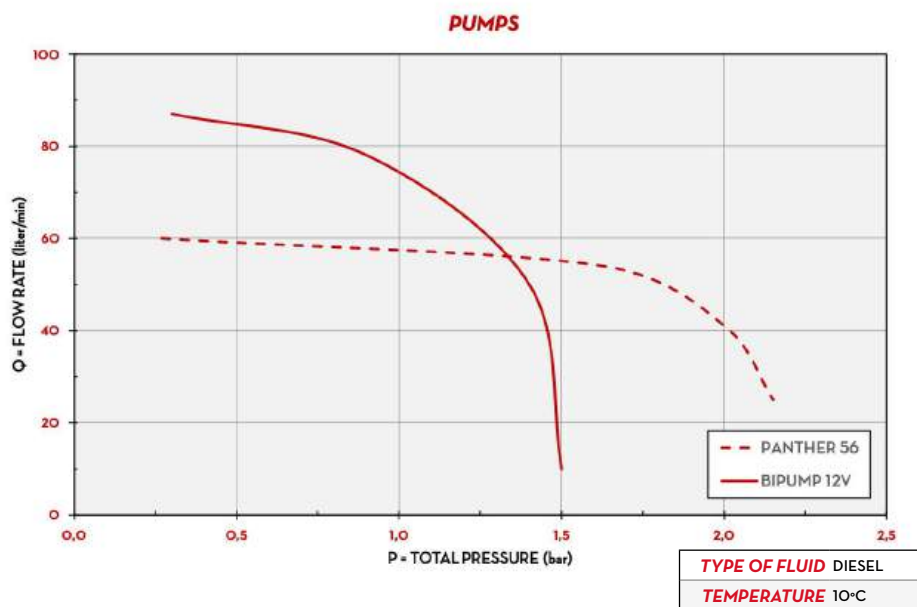

## DIMENSIONS

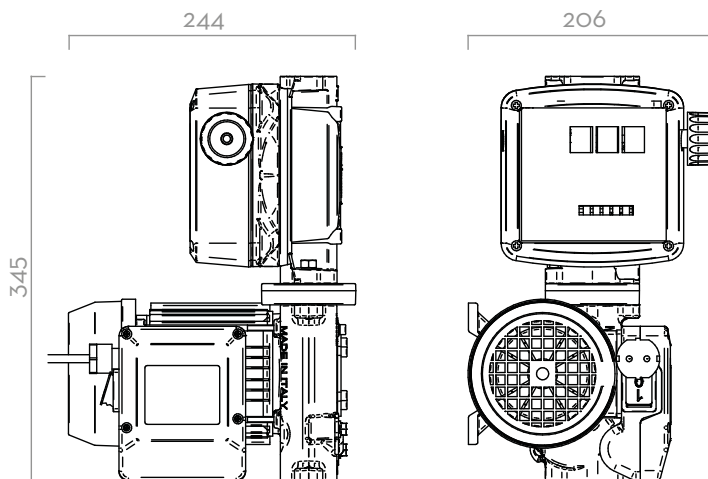

Dimensions expressed in millimeters

## IN THE BOX

- PUMP
- TELESCOPIC SUCTION PIPE
- DELIVERY HOSE
- NOZZLE
- 2" CONNECTOR
- K33 MECHANICAL METER (ON REQUEST)
- INSTRUCTION MANUAL

## DETAILS



2" CONNECTOR



TELESCOPIC SUCTION HOSE



ELECTRIC CABLE WITH CLAMPS (ONLY DC VERSION)

## COMPONENTS

- **PUMPS:**  
PANTHER AC  
BIPUMP  
PANTHER DC
- **METER:**  
K33

## TECHNICAL DATA

CODE		DESCRIPTION	FLUIDS TYPE	FLOW RATE		VOLTAGE			METER	NOZZLE	INLET	HOSE
WITHOUT METER	WITH METER			L/MIN	GPM	AC V./HZ DC VOLT	POWER WATT	AMP. MAX.				
000271POO	000272POO	DRUM PANTHER 56	D	56	15	230/50	350	3	K33	SELF2000	3/4"	4M
000273POO	000274POO	DRUM PANTHER 56 A60	D	56	15	230/50	350	3	K33	A60	3/4"	4M
-	FO022205A	DRUM BIPUMP 12V	D	80	21	12V	530	44	K33	SELF2000	1"	4M
-	FO022206A	DRUM BIPUMP 24V	D	80	21	24V	540	22,5	K33	SELF2000	1"	4M
-	FO022207A	DRUM BIPUMP 12V A120	D	80	21	12V	530	44	K33	A120	1"	4M
-	FO022208A	DRUM BIPUMP 24V A120	D	80	21	24V	540	22,5	K33	A120	1"	4M
-	FO03411IC	DRUM PANTHER DC 24/12V K33 A60	D	56	15	24/12V	420/150	25/16A	K33	A60	3/4"	4M



FUEL MANAGEMENT SYSTEMS



DISPENSERS



KITS



PUMPS



METERS



NOZZLES

# PICO

## FEATURES

- **READY TO USE**
- **WEATHER PROOF MATERIALS**
- **STURDY DESIGN**

The PIUSI PICO is a dispensing unit suitable to transfer diesel and antifreeze. It includes a centrifugal pump ready to be fit on any kind of drum (vertical installation with built-in connection). Automatic nozzle available on request.

### PERFORMANCE

UP TO

**35 L/MIN**

FLOW RATE

**AC/DC**

VOLTAGE

**± 1%**

ACCURACY



### PACKAGING

CODE	WEIGHT		PACKAGING		
	KG	LBS	MM	INCH	PCS/BOX
<b>WITHOUT METER</b>					
FOO202000	4,8	10,6	360X360X180	14,2X14,2X7,1	1
FOO202010	5,8	12,8	360X360X180	14,2X14,2X7,1	1
FOO202040	4,8	10,6	360X360X180	14,2X14,2X7,1	1
FOO202050	5,8	12,8	360X360X180	14,2X14,2X7,1	1



FILTRATION



TANK MONITORING



HOSE REEL



ACCESSORIES



MERCHANDISE

# PIUSI

INDEX

IS

ANY BIODIESEL

A

AIR

A

ANTIFREEZE

AdBlue®

BIODIESEL

D

DIESEL

F

FOOD

G

GASOLINE

G

GREASE

K

KEROSENE

O

OIL

W

WATER

W

WINDSCREEN

### CHART

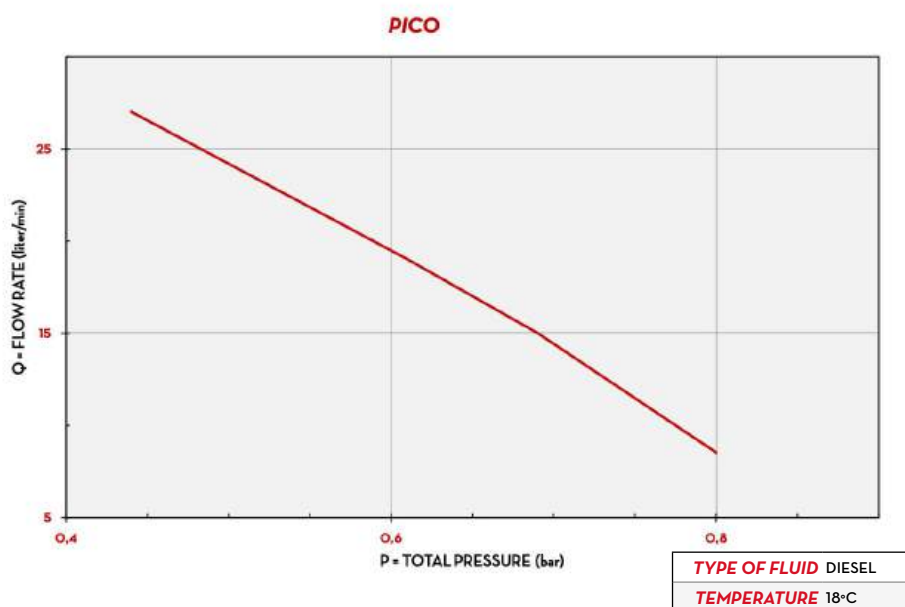

### DIMENSIONS

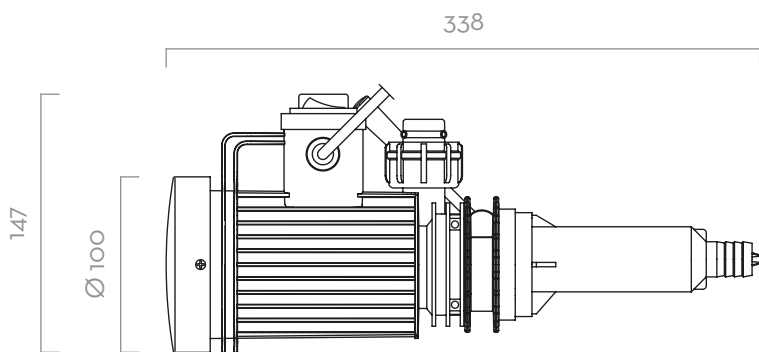

Dimensions expressed in millimeters

### IN THE BOX

- PICO UNIT
- DELIVERY HOSE
- SUCTION PIPE
- MANUAL/AUTOMATIC NOZZLE
- INSTRUCTION MANUAL

### DETAILS



ON/OFF SWITCH



VERSION WITH METER (OPTIONAL)



ELECTRIC CABLE WITH CLAMPS (ONLY DC VERSION)

### MATERIALS

- BODY: TECHNOPYLIMER

### DATI TECNICI

CODE	DESCRIPTION	FLUIDS TYPE	FLOW RATE		VOLTAGE			PUMP	DUTY CYCLE	NOZZLE	HOSE		FOOT FILTER	
			L/MIN	GPM	AC V/HZ	POWER WATT	AMP. MAX.				LENGHT	Ø		
<b>WITHOUT METER</b>														
FO0202000	PICO 230 M	A D W	35	9	230/50	224	1	PICO	-	MAN.	4M	3/4"	YES	
FO0202010	PICO 230 A	A D W	30	8	230/50	224	1	PICO	-	AUT.	4M	3/4"	YES	
FO0202040	PICO 12 M	A D W	30	8	12	110	9	PICO	30	MAN.	4M	3/4"	YES	
FO0202050	PICO 12 A	A D W	25	7	12	110	9	PICO	30	AUT.	4M	3/4"	YES	



FUEL MANAGEMENT SYSTEMS



DISPENSERS



KITS



PUMPS



METERS



NOZZLES

# BATTERY KIT

## FEATURES

- VERSATILITY
- MOBILE AND READY TO USE
- ON/OFF SWITCH

The PIUSI BATTERY KIT is a portable transfer unit with a self-priming electric vane pump. Its modular composition allows users to have different pumps according to the required flow rates and different applications. It is equipped with a fixed brush motor with permanent magnet stator and terminal board with switches and fuses to protect against overload. It is always supplied with integrated nozzle and a set of accessories.



### PERFORMANCE

UP TO <b>80 L/MIN</b>	12/24V
FLOW RATE	VOLTAGE
UP TO <b>30 MIN</b>	UP TO <b>2MT</b>
DUTY CICLE	SELF-PRIMING



BATTERY KIT 3000



### PACKAGING

CODE	WEIGHT		PACKAGING			N. BOXES / EUROPALLET	
	KG	LBS	MM	INCH	PCS/BOX	✈	🚛
<b>BATTERY KIT 3000</b>							
FO022500C	7,8	17,3	300X300X180	-	1	50	100
FO022600C	7,8	17,3	300X300X180	-	1	50	100
FO0225410	7,8	17,3	300X300X180	-	1	50	100
FO0226380	7,8	17,3	300X300X180	-	1	50	100
FO0225800	7,8	17,3	300X300X180	-	1	50	100
<b>BATTERY KIT PANTHER</b>							
FO034003B	7,8	17,3	300X300X180	-	1	24	36
FO034103C	7,8	17,3	300X300X180	-	1	24	36
FO0341220	13	28,7	357X357X275	-	1	24	36
<b>BATTERY KIT BIPUMP</b>							
FO0363280	18	39,7	480X370X265	-	1		



FILTRATION



TANK MONITORING



HOSE REEL



ACCESSORIES



MERCHANDISE

# PIUSI

INDEX



ANY BIODIESEL



AIR



ANTIFREEZE



AdBlue®



BIODIESEL



DIESEL



FOOD



GASOLINE



GREASE



KEROSENE



OIL



WATER



WINDSCREEN



BATTERY KIT BIPUMP

BATTERY KIT 3000 INLINE



BATTERY KIT PANTHER

### IN THE BOX

- PUMP
- SUCTION HOSE
- DELIVERY HOSE
- HANDLE
- NOZZLE
- MESH FILTER AND CONNECTIONS
- CABLES
- INSTRUCTION MANUAL

### DETAILS



ON/OFF SWITCH



HANDLE



ELECTRIC CABLE WITH CLAMPS

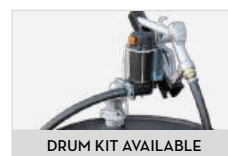

DRUM KIT AVAILABLE

### COMPONENTS

- DEPENDING ON PUMP MODEL, SEE REFERRED PAGES

## TECHNICAL DATA

CODE	DESCRIPTION	FLUIDS TYPE	FLOW RATE		VOLTAGE			FUSES CAPACITY AMPERE	PUMP TYPE	DUTY CYCLE MINUTES	NOZZLE TYPE	HOSE		CHECK FILTER
			L/MIN	GPM	DC VOLT	POWER WATT	AMP. MAX.					LENGTH	Ø	
<b>BATTERY KIT 3000</b>														
FO022500C	BATTERY KIT 3000 12V	D	50	13	12	220	22	25	BP3000	30	SELF 2000	4M	3/4"	YES
FO022600C	BATTERY KIT 3000 24V	D	50	13	24	310	13	15	BP3000	30	SELF 2000	4M	3/4"	YES
FO0225410	BATTERY KIT 3000 INLINE 12V	D	50	13	12	220	22	25	BP3000	30	SELF 2000	4M	3/4"	YES
FO0226380	BATTERY KIT 3000 INLINE 24V	D	50	13	24	310	13	15	BP3000	30	SELF 2000	4M	3/4"	YES
FO0225800	BATTERY KIT 3000/12V BIO	Bio D	50	13	12	220	22	25	BP3000 BIO	30	SELF 2000 BIO	4M	3/4"	YES
<b>BATTERY KIT PANTHER</b>														
FO034003B	BATTERY KIT PANTHER 12V	D	56	15	12	300	35	40	PANTHER DC	30	SELF 2000	4M	3/4"	YES
FO034103C	BATTERY KIT PANTHER 12-24V	D	35/70	9/18	24/12	420/150	25/16	30	PANTHER DC	30	SELF 2000	4M	3/4"	YES
FO0341220	BATTERY KIT PANTHER 12-24V	D	35/70	9/18	12/24	600/200	25/16	30	PANTHER DC	30	A60	5M	3/4"	YES
<b>BATTERY KIT BIPUMP</b>														
FO0363280	BATTERY KIT BIPUMP 12V	D	80	21	12	300	22	40	BIPUMP DC	30	A120	6M	1"	YES



FUEL MANAGEMENT SYSTEMS



DISPENSERS



KITS



PUMPS



METERS



NOZZLES

# PITSTOP

## FEATURES

- **READY TO INSTALL**
- **VERSATILITY**
- **STURDY STRUCTURE**

The PIUSI PITSTOP is a dispenser unit with two DC pumps, automatic hose reel, water filter and automatic nozzle with 14 meter. hose integrated into a sturdy supporting structure. Easy to install, versatile and compact, this dispenser is the all-in-one solution for setting up a perfect mobile refueling unit.

### PERFORMANCE

UP TO

**45 L/MIN**

FLOW RATE

**12/24V**

VOLTAGE

POWER

**14MT**

HOSE LENGTH

HOSE REEL

**200β/30μ**

FILTERING CAPACITY



PITSTOP



### PACKAGING

CODE	WEIGHT		PACKAGING		
	KG	LBS	MM	INCH	PCS/BOX
FO0212000	45	99	595X465X670	23,4X13,5X24,4	1
FO0213000	45	99	595X465X670	23,4X13,5X24,4	1



FILTRATION



TANK MONITORING



HOSE REEL



ACCESSORIES



MERCHANDISE

# PIUSI

INDEX

B

ANY BIODIESEL

A

AIR

A

ANTIFREEZE

Ad

AdBlue®

B

BIODIESEL

D

DIESEL

F

FOOD

G

GASOLINE

G

GREASE

K

KEROSENE

O

OIL

W

WATER

W

WINDSCREEN

## CHART

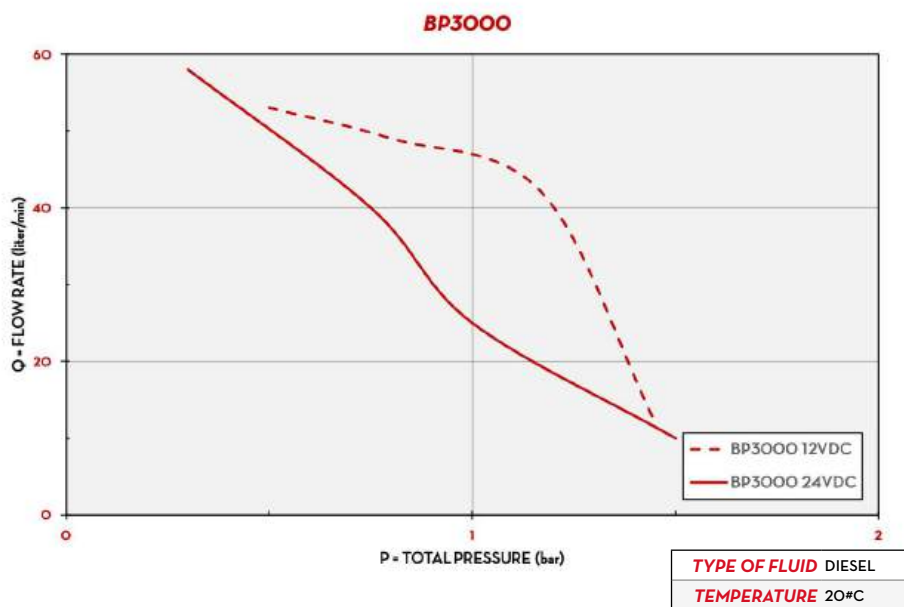

## DIMENSIONS

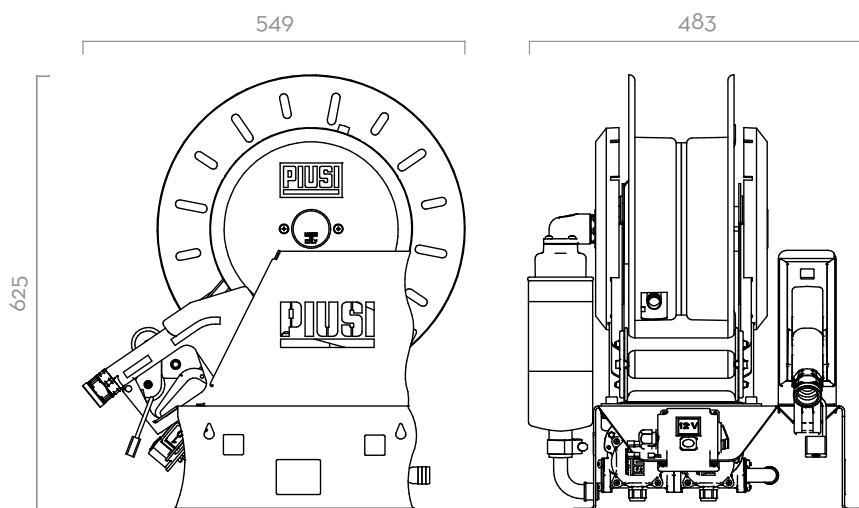

Dimensions expressed in millimeters

## IN THE BOX

- PITSTOP UNIT
- AUTOMATIC NOZZLE
- FILTER
- INSTRUCTION MANUAL

## DETAILS



ON/OFF SWITCH



PAD LOCK



BUILT-IN DC PUMPS



ADJUSTABLE ARM

## COMPONENTS

- **PUMP:**  
BP3000
- **FILTER:**  
WATER CAPTOR
- **NOZZLE:**  
A60

## TECHNICAL DATA

CODE	DESCRIPTION	FLUIDS TYPE	FLOW RATE		VOLTAGE			PUMP		DUTY CYCLE	NOZZLE	HOSE		INLET
			L/MIN	GPM	AC V./HZ	DC VOLT	POWER WATT	AMP. MAX.	TYPE			N°	MINUTES	
FOO212000	PIUSI PITSTOP DC 12V	D	45	11,9	12	400	33	BP 3000	2	30	A60	14M	3/4"	1"
FOO213000	PIUSI PITSTOP DC 24V	D	45	11,9	24	620	26	BP 3000	2	30	A60	14M	3/4"	1"



FUEL MANAGEMENT SYSTEMS



DISPENSERS



KITS



PUMPS



METERS



NOZZLES

# PIUSIBOX

## FEATURES

- SELF PRIMING PUMP
- BUILT-IN FILTER (PRO VERSION)
- EASY TO REPACK
- IP55

The PIUSIBOX is a portable fuel dispenser integrated with a self-priming transfer pump, filter, check valve and manual nozzle. Suitable for quick and safe refuel operations in all the situations where an easy mobile refueling solution is required.

### PERFORMANCE

UP TO

**45 L/MIN**

FLOW RATE

**12/24V**

VOLTAGE

POWER

**30 MIN**

DUTY CICLE



PIUSIBOX



### PACKAGING

CODE	WEIGHT		PACKAGING			N. BOXES / EUROPALLET	
	KG	LBS	MM	INCH	PCS/BOX		
FOO23100B	9,5	20,9	400X300X420	-	1	24	32
FOO23101B	12	26,5	400X300X420	-	1	24	32
FOO23200B	9,5	20,9	400X300X420	-	1	24	32
FOO23201B	12	26,5	400X300X420	-	1	24	32





FILTRATION



TANK MONITORING



HOSE REEL



ACCESSORIES



MERCHANDISE

# PIUSI

INDEX

B

ANY BIODIESEL

A

AIR

A

ANTIFREEZE

Ad

AdBlue®

B

BIODIESEL

D

DIESEL

F

FOOD

G

GASOLINE

G

GREASE

K

KEROSENE

O

OIL

W

WATER

W

WINDSCREEN

## CHART

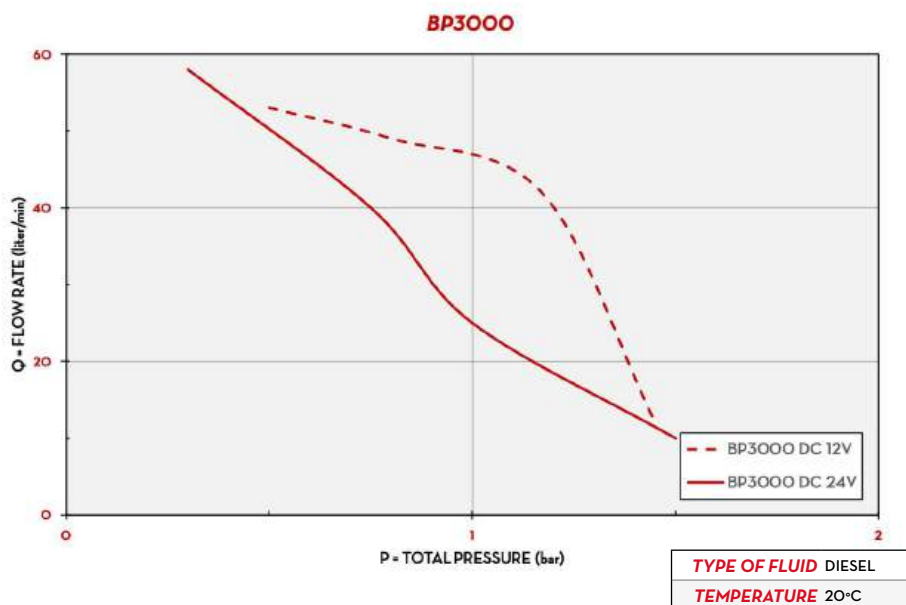

## DIMENSIONS

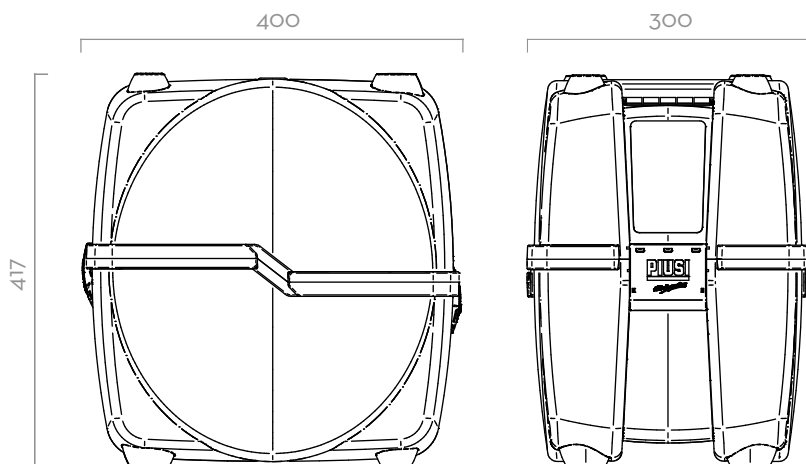

Dimensions expressed in millimeters

## IN THE BOX

- PIUSIBOX UNIT
- SUCTION&DELIVERY HOSE
- OIL&FUEL FILTER (PRO VERSION)
- CHECK VALVE
- INSTRUCTION MANUAL

## DETAILS



CHECK VALVE



ERGONOMIC HANDLE



ROTATING CONNECTION

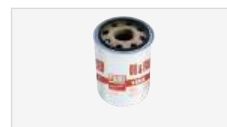

CARTRIDGE

## MATERIALS

- BODY: CAST IRON
- ROTOR: SINTERED STEEL
- VANES: ACETAL RESIN
- SEAL: NBR
- SHAFT: STEEL

## TECHNICAL DATA

CODE	DESCRIPTION	FLUIDS TYPE	FLOW RATE		VOLTAGE			PUMP TYPE	DUTY CYCLE MINUTES	FILTER	CARTRIDGE	NOZZLE TYPE	DELIVERY HOSE 5/8"	SUCTION HOSE 3/4"	FOOT VALVE MOD. VANTAGE
			L/MIN	GPM	AC V/HZ DC VOLT	POWER WATT	AMP. MAX.								
FOO23100B	PIUSIBOX 12V BASIC	D	45	11,9	12	260	22	BP 3000	30	NO	NO	MAN.	4M	2M	YES
FOO23101B	PIUSIBOX 12V PRO	D	43	11,7	12	260	22	BP 3000	30	YES	10μ	MAN.	4M	2M	YES
FOO23200B	PIUSIBOX 24V BASIC	D	45	11,9	24	310	12	BP 3000	30	NO	NO	MAN.	4M	2M	YES
FOO23201B	PIUSIBOX 24V PRO	D	43	11,7	24	310	12	BP 3000	30	YES	10μ	MAN.	4M	2M	YES



FUEL MANAGEMENT SYSTEMS



DISPENSERS



KITS



PUMPS



METERS



NOZZLES

# CARRY

## FEATURES

- EASY TO INSTALL
- SAFE TO MOVE
- LONG LASTING APPLICATION

The PIUSI CARRY pump is a diesel transfer DC pump designed to meet the needs of those who are looking for a long-lasting, high quality and portable pump. CARRY 3000 is equipped with a sturdy handle to allow easy carriage and comes complete with dispensing pipe, power cables and the dispensing nozzle.

### PERFORMANCE

UP TO  
**70 L/MIN**

FLOW RATE

**12/24V**

VOLTAGE  
POWER

**30 MIN**

DUTY CYCLE



CARRY PANTHER

CARRY



CARRY 3000 INLINE

### PACKAGING

CODE	WEIGHT		PACKAGING			N. BOXES / EUROPALLET	
	KG	LBS	MM	INCH	PCS/BOX	✕	
FO022300C	4,2	9,3	260X235X164	-	1	84	120
FO022400C	4,2	9,3	260X235X164	-	1	84	120
FO0223260	4,2	9,3	260X235X164	-	1	84	120
FO0224240	4,2	9,3	260X235X164	-	1	84	120
FO034004B	4,2	9,3	260X235X164	-	1	84	120
FO034104C	4,2	9,3	260X235X164	-	1	84	120



FILTRATION



TANK MONITORING



HOSE REEL



ACCESSORIES



MERCHANDISE

# PIUSI

INDEX

B

ANY BIODIESEL

A

AIR

A

ANTIFREEZE

Ad

AdBlue®

B

BIODIESEL

D

DIESEL

F

FOOD

G

GASOLINE

G

GREASE

K

KEROSENE

O

OIL

W

WATER

W

WINDSCREEN

## CHART



## IN THE BOX

- CARRY PUMP
- HANDLE
- ELECTRIC CABLE WITH CLAMPS
- CONNECTIONS
- INSTRUCTION MANUAL

## DETAILS



STURDY HANDLE



ELECTRIC CABLE WITH CLAMPS

## DIMENSIONS

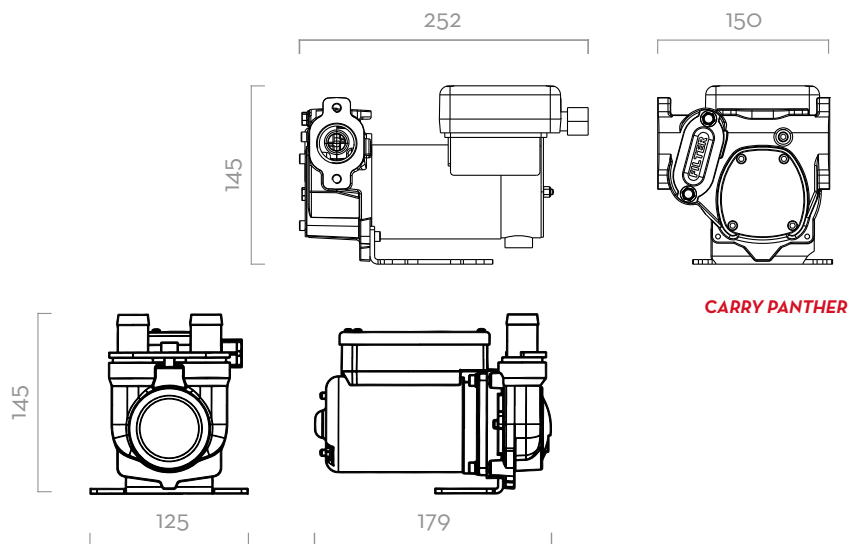

CARRY

Dimensions expressed in millimeters

## MATERIALS

- BODY: CAST IRON
- ROTOR: SINTERED STEEL
- VANES: ACETAL RESIN
- SEAL: NBR
- SHAFT: STEEL

## TECHNICAL DATA

CODE	DESCRIPTION	FLUIDS TYPE	FLOW RATE		VOLTAGE			FUSES CAPACITY AMPERE	DUTY CYCLE MINUTES	RPM	PRESSURE MAX BAR	ON/OFF SWITCH	INLET/OUTLET BSP
			L/MIN	GPM	DC VOLT	POWER WATT	AMP. MAX.						
FOO22300C	CARRY 3000 12V	D	50	13	12	300	24	25	30	2900	1,5	YES	3/4"
FOO22400C	CARRY 3000 24V / 12V	D	50/30	13/6	24/12	310/80	13/6,5	15	30	2900/1500	1,5	YES	3/4"
FOO223260	CARRY 3000 INLINE 12V	D	50	13	12	300	24	25	30	2900	1,5	YES	3/4"
FOO224240	CARRY 3000 INLINE 24V	D	50/30	13/6	24/12	310/80	24	15	30	2900/1500	1,5	YES	3/4"
FOO34004B	CARRY PANTHER 12V	D	56	15	12	420	13/6,5	40	30	2900	4	YES	1"
FOO34104C	CARRY PANTHER 12V / 24V	D	35/70	9/18	24/12	600/200	13/6,5	30	30	3500/1800	4	YES	1"



FUEL MANAGEMENT SYSTEMS



DISPENSERS



KITS



PUMPS



METERS



NOZZLES

# ST

## FEATURES

- RAYD TO USE
- EASY TO INSTALL
- STURDY STRUCTURE
- COMPACT DEISGN
- AVAILABLE WITH DIFFERENT PUMPS

The PIUSI ST is a versatile and compact diesel transfer station that can be used to fill mobile tanks or interact with distribution units. It is fitted with check valve, filter, nozzle and 4mt delivery hose. Its sturdy structure makes this dispenser suitable to be used in the harshest environments. It can be integrated with a protective metal box and water separating filter.

### PERFORMANCE

UP TO

**90 L/MIN**

FLOW RATE

**AC/DC**

VOLTAGE

POWER

**4MT**

LENGTH

DELIVERY HOSE

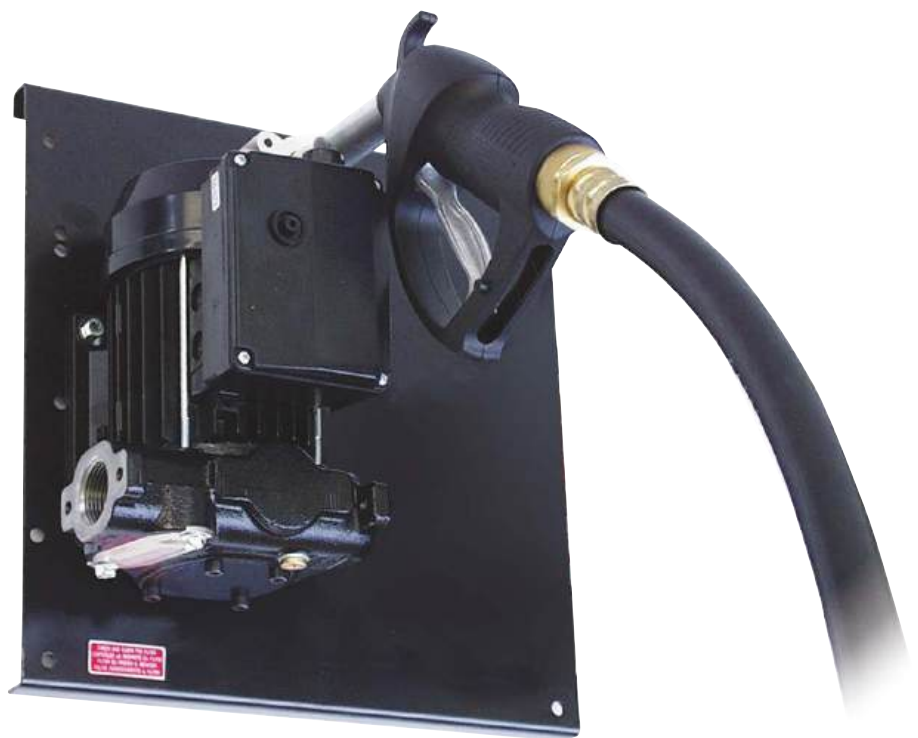

ST



### PACKAGING

CODE	WEIGHT		PACKAGING		
	KG	LBS	MM	INCH	PCS/BOX
000266P00	16	35	357X357X275	14,1X14,1X10,8	1
000286P00	16	35	357X357X275	14,1X14,1X10,8	1
000266P20	21	46	357X357X275	14,1X14,1X10,8	1
000214000	21	46	357X357X275	14,2X14,2X11,8	1
000216000	23	50	480X370X265	18,9X14,6X10,4	1
FO021000B	10	22	357X357X275	14,1X14,1X10,8	1
FO021100B	10	22	357X357X275	14,1X14,1X10,8	1
FO0340080	19	42	357X357X275	14,1X14,1X10,8	1



FILTRATION



TANK MONITORING



HOSE REEL



ACCESSORIES



MERCHANDISE

# PIUSI

INDEX

B

ANY BIODIESEL

A

AIR

A

ANTIFREEZE

Ad

AdBlue®

B

BIODIESEL

D

DIESEL

F

FOOD

G

GASOLINE

G

GREASE

K

KEROSENE

O

OIL

W

WATER

W

WINDSCREEN

### AVAILABLE WITH DIFFERENT PUMPS

### IN THE BOX

- ST UNIT
- DELIVERY HOSE
- NOZZLE
- NOZZLE HOLDER
- INSTRUCTION MANUAL



AC PUMP - PANTHER



AC PUMP - E80



AC PUMP - E120



AC PUMP - VISCOMAT VANE



DC PUMP - BP3000



DC PUMP - PANTHER DC

### DETAILS



MANUAL NOZZLE



AUTOMATIC NOZZLE

### DIMENSIONS

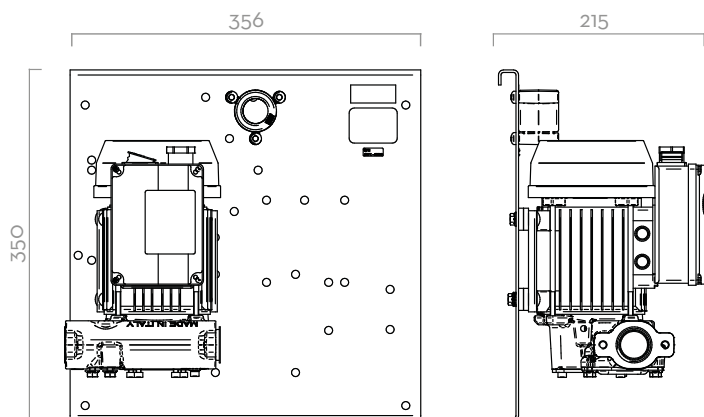

Dimensions expressed in millimeters

### COMPONENTS

- PUMPS:
  - PANTHER AC
  - E80/E120
  - VISCOMAT VANE
  - BP3000
  - PANTHER DC
- NOZZLE:
  - MANUAL NOZZLE
  - AUTOMATIC NOZZLE

### TECHNICAL DATA

CODE	DESCRIPTION	FLUIDS TYPE	FLOW RATE		VOLTAGE			METER	NOZZLE	FILTER	DELIVERY HOSE		OUTLET	
			L/MIN	GPM	AC V./HZ	DC VOLT	POWER WATT				AMP. MAX.	LENGTH	Ø	bsp
000266P00	ST PANTHER 56	D	56	15	230/50	350	3	NO	SELF 3000	NO	4M	3/4"	1"	
000286P00	ST PANTHER 56 A60	D	56	15	230/50	350	3	NO	A60	NO	4M	3/4"	1"	
000266P20	ST PANTHER 72/M	D	72	19	230/50	500	4,2	NO	SELF 3000	NO	4M	3/4"	1"	
000214000	ST E 80	D	80	21	230/50	700	3,5	NO	SELF 3000	NO	4M	1"	1"	
000216000	ST E 120	D	90	24	230/50	1150	5,7	NO	SELF 3000	NO	4M	1"	1"	
FOO21000B	ST BYPASS 3000 12V	D	42	11	12	260	22	NO	SELF 3000	NO	4M	3/4"	1"	
FOO21100B	ST BYPASS 3000 24V	D	42	11	24	300	12	NO	SELF 3000	NO	4M	3/4"	1"	
FOO340080	ST PANTHER DC 12V	D	56	15	12	420	35	NO	SELF 3000	NO	4M	3/4"	1"	

THE UNIT CAN ALSO BE SUPPLIED FOR OPERATING UNDER DIFFERENT VOLTAGES AND WITHOUT METER.



FUEL MANAGEMENT SYSTEMS



DISPENSERS



KITS



PUMPS



METERS



NOZZLES

# ST WITH METER

## FEATURES

- **READY TO USE**
- **EASY TO INSTALL**
- **STURDY STRUCTURE**
- **HIGH PRECISION METER**
- **AVAILABLE WITH DIFFERENT PUMPS**

The PIUSI ST WITH METER is a diesel transfer station for fixed installations composed by AC or DC pump, nozzle (manual or automatic) and precision meter - both mechanical (K33) or electronic (K600 B/3) - for safe and controlled refueling operations. Easy to install, this station can be used to fill mobile tanks or interact with distribution units.

### PERFORMANCE

UP TO

**90 L/MIN**

FLOW RATE

**AC/DC**

VOLTAGE

POWER

**± 1%**

ACCURACY

**4MT**

LENGTH

DELIVERY HOSE



ST WITH METER



METALLIC BOX (optional)



### PACKAGING

CODE	WEIGHT		PACKAGING		
	KG	LBS	MM	INCH	PCS/BOX
FO0385POA	16	35	357X357X275	14,1X14,1X10,8	1
FO0287POA	16	35	357X357X275	14,1X14,1X10,8	1
OO0390000	21	46	357X357X275	14,1X14,1X10,8	1
OO0392000	23	50	357X357X275	14,2X14,2X11,8	1
OO0395000	23	50	480X370X265	18,9X14,6X10,4	1
OO0395050	24	53	480X370X275	18,9X14,6X11,8	1
OO0397000	20	44	480X370X265	18,9X14,6X10,4	1
OO0287P40	19	41	357X357X275	14,1X14,1X10,8	1
FO023500B	13	29	357X357X275	14,1X14,1X10,8	1
FO023600B	13	29	357X357X275	14,2X14,2X11,8	1
FO023300B	14	31	480X370X265	18,9X14,6X10,4	1
FO023400B	14	31	480X370X265	18,9X14,6X10,4	1
FO024000A	24	53	357X357X275	14,1X14,1X10,8	1
FO024003A	24	53	357X357X275	14,1X14,1X10,8	1
FO024100A	24	53	357X357X275	14,1X14,1X10,8	1
FO024101A	11	11	357X357X275	14,1X14,1X10,8	1
FO0340070	17	37	357X357X275	14,1X14,1X10,8	1
FO0340160	17	11	357X357X275	14,1X14,1X10,8	1



FILTRATION



TANK MONITORING



HOSE REEL



ACCESSORIES



MERCHANDISE

**PIUSI**

INDEX

B

ANY BIODIESEL

A

AIR

A

ANTIFREEZE

Ad

AdBlue®

B

BIODIESEL

D

DIESEL

F

FOOD

G

GASOLINE

G

GREASE

K

KEROSENE

O

OIL

W

WATER

W

WINDSCREEN

AVAILABLE WITH DIFFERENT PUMPS

IN THE BOX



AC PUMP - PANTHER 56/72



AC PUMP - E80/E120



AC PUMP - VISCOMAT 70/90

- ST WITH METER UNIT
- METER
- DELIVERY HOSE
- NOZZLE
- NOZZLE HOLDER
- INSTRUCTION MANUAL



DC PUMP - BYPASS 3000



DC PUMP - PANTHER DC



DC PUMP - BIPUMP

DETAILS



K33 / K600 B/3



MAN. / AUTOM. NOZZLE

DIMENSIONS

COMPONENTS

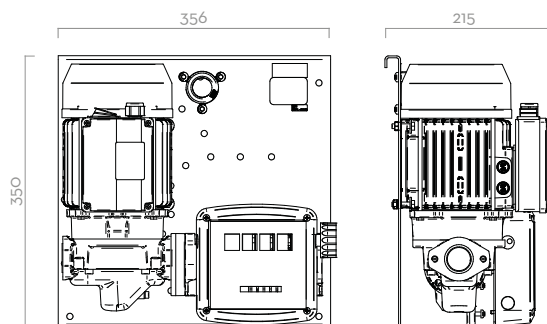

Dimensions expressed in millimeters

- PUMPS:  
PANTHER AC  
E80/E120  
VISCOMAT VANE  
BP3000  
PANTHER DC  
BIPUMP
- NOZZLE:  
MANUAL NOZZLE  
AUTOMATIC NOZZLE
- METERS:  
K33  
K600 B/3

TECHNICAL DATA

CODE	DESCRIPTION	FLUIDS TYPE	FLOW RATE		VOLTAGE			METER	NOZZLE	SUCTION HOSE	HOSE		OUTLET
			L/MIN	GPM	AC V/HZ DC VOLT	POWER WATT	AMP. MAX.				LENGTH (M)	Ø (MM)	
FOO385POA	ST PANTHER 56 K33	D	56	15	230/50	350	3	K33	SELF 3000	NO	4	20	3/4"
FOO287POA	ST PANTHER 56 K33 A60	D	56	15	230/50	350	3	K33	A60	NO	4	20	3/4"
OOO390000	ST E80 K33	D	80	21	230/50	700	3,5	K33	SELF 3000	NO	4	25	1"
OOO392000	ST E80 K33 A80	D	75	20	230/50	700	3,5	K33	A80	NO	4	25	1"
OOO395000	ST E120 K33	D	90	24	230/50	1150	5,7	K33	SELF 3000	NO	4	25	1"
OOO395050	ST E120/M K44	D	90	24	230/50	1150	5,7	K44	SELF 3000	NO	4	25	1"
OOO397000	ST E120 K33 A120	D	90	24	230/50	1150	5,7	K33	A120	NO	4	25	1"
OOO287P40	ST PANTHER 72/M K33 A80	D	72	19	230/50	500	4,2	K33	A80	NO	4	25	1"
FOO23500B	ST BYPASS 3000/12V K33	D	40	10	12	260	22	K33	SELF 3000	NO	4	20	3/4"
FOO23600B	ST BYPASS 3000 INLINE 24V K33	D	40	10	24	300	12	K33	SELF 3000	NO	4	20	3/4"
FOO23300B	ST BYPASS 3000/12V K33 A60	D	35	9	12	260	22	K33	A60	NO	4	20	3/4"
FOO23400B	ST BYPASS 3000 INLINE 24V K33 A60	D	35	9	24	300	12	K33	A60	NO	4	20	3/4"
FOO24000A	ST BIPUMP 12V K33 SELF 3000	D	80	21	12	530	44	K33	SELF 3000	NO	4	25	1"
FOO24003A	ST BIPUMP 12V K33 A120	D	80	21	12	530	44	K33	A120	NO	4	25	1"
FOO24100A	ST BIPUMP 24V K33 SELF 3000	D	80	21	24	540	22,5	K33	SELF 3000	NO	4	25	1"
FOO24101A	ST BIPUMP 24V K33 A120	D	80	21	24	540	22,5	K33	A120	NO	4	25	1"
FOO340070	ST PANTHER 12V K33 A60	D	56	15	12	420	35	K33	A60	NO	4	20	3/4"
FOO340160	ST PANTHER DC 12/24V K33 A60	D	70/35	18,5/9,2	24/12	420/150	25/16	K33	A60	NO	4	20	3/4"



FUEL MANAGEMENT SYSTEMS



DISPENSERS



KITS



PUMPS



METERS



NOZZLES

# ST WITH METER AND FILTER

## FEATURES

- READY TO USE
- VERSATILE
- EASY TO INSTALL
- COMPACT DESIGN
- FILTRATION GUARANTEED
- AVAILABLE WITH DIFFERENT PUMPS

PIUSI ST WITH METER AND FILTER is a range of dispensers particularly suited for all applications in which a filtration is required. The stations integrate PIUSI CLEAR or WATER CAPTOR FILTERS and are available with mechanical meter K33 or electronic meter K24/K600 B/3. They come with integrated check valve and 4-meter delivery hose.

### PERFORMANCE

UP TO <b>90 L/MIN</b>	<b>AC</b> CONTINUOUS DUTY
FLOW RATE	POWER
<b>± 1%</b>	UP TO <b>6MT</b> LENGTH
ACCURACY	DELIVERY HOSE



ST PANTHER 56, K33, A60 E WATER CAPTOR



ST PANTHER 56, K33, A60 E CLEAR CAPTOR



ST PANTHER 72 BIO, K33 BIO, A70 BIO AND FILTER BIODIESEL

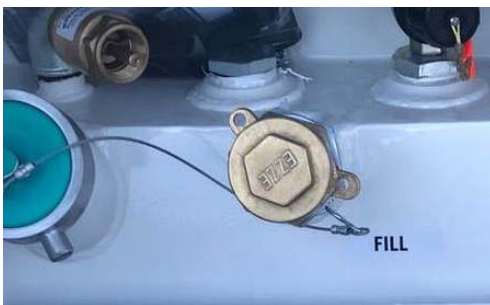

FILL



### PACKAGING

CODE	WEIGHT		PACKAGING		
	KG	LBS	MM	INCH	PCS/BOX
FO0386FOA	25	55	580X380X320	22,8X15X12,6	1
FO0265FOA	26	57	580X380X320	22,8X15X12,6	1
FO0395FOA	32	71	545X435X340	21,5X17,1X13,4	1
FO0386F60	22	48	380X380X480	15X15X18,9	1
FO0386R70	22	48	380X380X480	15X15X18,9	1
FO0265F40	26	57	580X380X320	22,8X15X12,6	1
FO0265S80	26	57	580X380X320	22,8X15X12,6	1
FO0395F60	32	71	545X435X340	21,5X17,1X13,4	1
FO0265S20	18	40	480X370X260	18,9X14,6X10,2	1
FO0265R70	18	40	480X370X260	18,9X14,6X10,2	1
FO0395B00	29	63	560X450X370	22X17X14,5	1
FO0265B00	21	46	580X400X340	22,8X15,7X13,3	1





FILTRATION



TANK MONITORING



HOSE REEL



ACCESSORIES



MERCHANDISE

# PIUSI

INDEX



ANY BIODIESEL



AIR



ANTIFREEZE



AdBlue®



BIODIESEL



DIESEL



FOOD



GASOLINE



GREASE



KEROSENE



OIL



WATER



WINDSCREEN

### AVAILABLE WITH DIFFERENT PUMPS AND METERS



AC PUMP - PANTHER 56/72



AC PUMP - E120



AUTOMATIC NOZZLE

### IN THE BOX

- ST WITH METER AND FILTER
- METER
- FILTER
- DELIVERY HOSE
- NOZZLE
- NOZZLE HOLDER
- INSTRUCTION MANUAL



MECHANICAL METER - K33



ELECTRONIC METER - K24



K600 B/3

### DETAILS



WATER CAPTOR FILTER



MAN. / AUTOM. NOZZLE



K24 / K600 B/3 METER



K33 METER

### DIMENSIONS

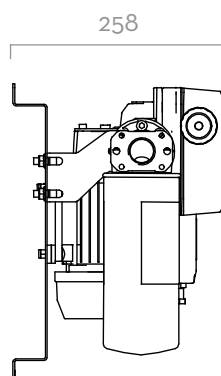
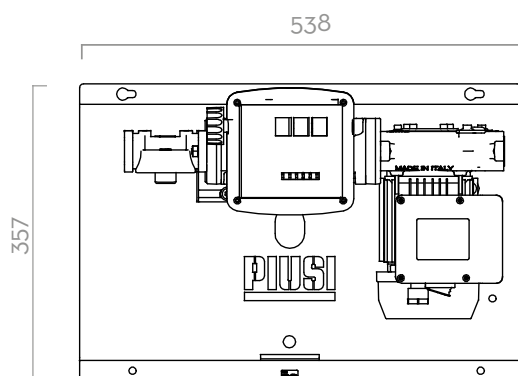

Dimensions expressed in millimeters

### COMPONENTS

- PUMPS:  
PANTHER AC  
E80/E120
- NOZZLE:  
AUTOMATIC NOZZLE
- METER:  
K33  
K24  
K600 B/3
- FILTER  
WATER CAPTOR

### TECHNICAL DATA

CODE	DESCRIPTION	FLUIDS TYPE	FLOW RATE		VOLTAGE			METER	NOZZLE	FILTER	DELIVERY HOSE		SUCTION HOSE		INLET
			L/MIN	GPM	AC V/ HZ	POWER. WATT	AMP. MAX.				LENGHT	Ø	LENGHT	BSP	
FOO386FOA	ST PANTHER 56 FILTER + A60	D	52	14	230/50	350	3	K33	A60	YES	6M	3/4"	4M	1"	
FOO265FOA	ST PANTHER 72 FILTER + A60	D	70	18	230/50	500	4,2	K33	A60	YES	6M	3/4"	4M	1"	
FOO395FOA	ST E120 FILTER + A120	D	85	22	230/50	1150	5,7	K33	A120	YES	6M	1"	4M	1"	
FOO386F60	ST PANTHER 56 FILTER + A60	D	52	14	230/50	350	3	K33	A60	YES	6M	3/4"	-	-	
FOO386R70	ST PANTHER 56 + CLEAR CAPTOR + A60	D	52	14	230/50	350	3	K33	A60	YES	6M	3/4"	-	-	
FOO265F40	ST PANTHER 72 FILTER + A60	D	70	18	230/50	500	4,2	K33	A60	YES	6M	3/4"	-	-	
FOO265S80	ST PANTHER 72 K600 B/F/6T/PA60	D	70	18	230/50	500	4,2	K600 B/3	A60	YES	6M	1"	-	-	
FOO395F60	ST E 120 FILTER + A120	D	85	22	230/50	1150	5,7	K33	A120	YES	6M	1"	-	-	
FOO265S20	ST PANTHER 72 FILTER + K24 METER	D	70	18	230/50	500	4,2	K24	A80	YES	6M	3/4"	-	-	
FOO265R70	ST PANTHER 72 + CLEAR CAPTOR + A80	D	70	18	230/50	500	4,2	K24	A80	YES	6M	1"	-	-	
FOO395B00	ST E120 K150/F/6MT/PA120 B100	BIO D	85	22	230/50	1150	5,7	K150 BIO	A120 BIO	NO	6M	1"	-	-	
FOO265B00	ST PANTHER 72 K33/F/6MT/PA70 B100	BIO D	70	18	230/50	500	4,2	K33 BIO	A70 BIO	NO	6M	3,4"	-	-	



FUEL MANAGEMENT SYSTEMS



DISPENSERS



KITS



PUMPS



METERS



NOZZLES

# ST BOX

## FEATURES

- STURDY STRUCTURE
- LOCKABLE AND SAFE
- READY TO USE
- FILTRATION GUARANTEED
- NOZZLE CONTACT (PRO VERSION ONLY)

The PIUSI ST BOX is a diesel refueling station complete with pump, flow meter and filter, with lockable metal protection box. The unit is complete with antistatic hose for diesel fuel and automatic dispensing nozzle. The PRO version features the electronic access control box (ACCESS 85).

### PERFORMANCE

UP TO  
**90 L/MIN**

FLOW RATE

**AC**  
CONTINUOUS DUTY

POWER

**± 1%**

ACCURACY



### PACKAGING

CODE	WEIGHT		PACKAGING		
	KG	LBS	MM	INCH	PCS/BOX
FO0365020	-	-	-	-	-
FO0365050	36	72	575X320X607	22,6X12,6X23,9	1
FO039900A	50	110	590X340X720	23,2X13,4X28,3	1
FO0365010	40	88	575X320X607	22,6X12,6X23,9	1
FO0365B40	40	88	575X320X607	22,6X12,6X23,9	1
FO0365B30	40	88	575X320X607	22,6X12,6X23,9	1



FILTRATION



TANK MONITORING



HOSE REEL



ACCESSORIES



MERCHANDISE

# PIUSI

INDEX



ANY BIODIESEL



AIR



ANTIFREEZE



AdBlue®



BIODIESEL



DIESEL



FOOD



GASOLINE



GREASE



KEROSENE



OIL



WATER



WINDSCREEN

## CHART

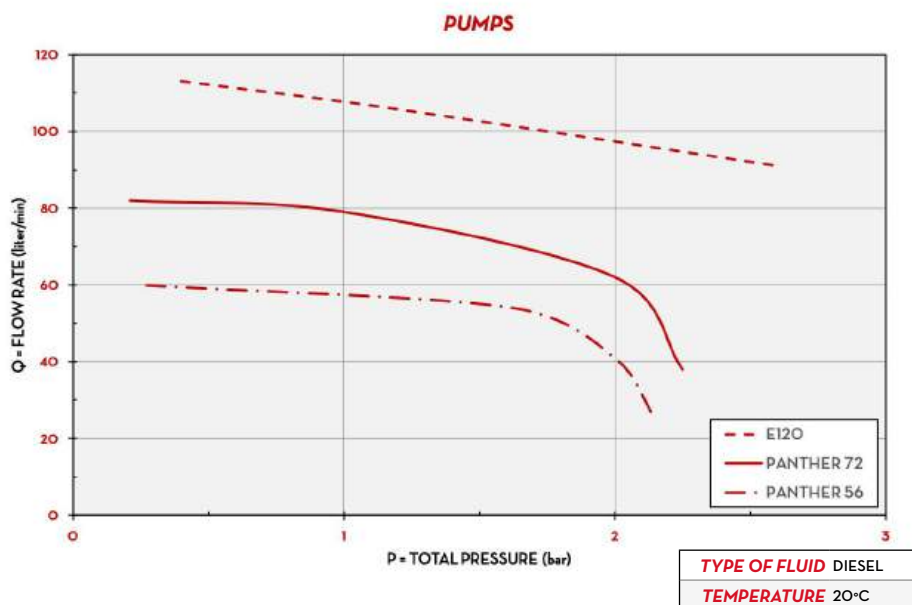

## DIMENSIONS

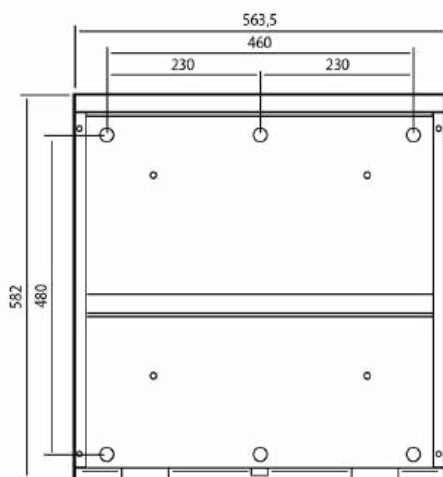

Dimensions expressed in millimeters

## IN THE BOX

- ST BOX UNIT
- METER
- FILTER
- DELIVERY HOSE
- NOZZLE
- INSTRUCTION MANUAL

## DETAILS



K33 MECH. METER



WATER CAPTOR FILTER

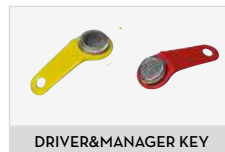

DRIVER&MANAGER KEY



ACCESS 85

## COMPONENTS

- PUMPS:  
PANTHER AC  
E80/E120  
BIPUMP
- NOZZLE:  
AUTOMATIC NOZZLE
- METER:  
K33  
K24
- FILTER  
WATER CAPTOR
- ACCESS CONTROL  
ACCESS85

## TECHNICAL DATA

CODE	DESCRIPTION	FLUIDS TYPE	FLOW RATE		VOLTAGE			PUMP	METER	NOZZLE	FILTER	HOSE		INLET
			L/MIN	GPM	AC V./HZ DC VOLT	POWER WATT	AMP. MAX.					LENGTH	Ø	
FO0365020	ST BOX PANTHER 56 BASIC	D	56	15	230/50	350	3	PANTH. 56	K33	A60	YES	6M	1"	1"
FO0365050	ST BOX E 120 BASIC	D	90	22	230/50	750	5,7	E 120	K33	A120	YES	8M	1"	1"
FO039900A	ST BOX BIPUMP 12V K33 A120	D	80	21	12	530	44	BIPUMP	K33	A80	NO	4M	1"	1"
FO0365010	ST BOX PANTHER 72 PRO - ACCESS 85	D	70	19	230/50	500	4,2	PANTH.72	K33	A60	YES	8M	1"	1"
FO0365B40	ST BOX P72M K600 B/3 PULS A70 WC 6M B100	D, B	70	19	230/50	500	4,2	PANTH.72	K600	A70	YES	6M	1"	1"
FO0365B30	ST CASSETTA P72/M K33 A70 WC 6MT B100	D, B	70	19	230/50	500	4,2	PANTH.72	K33	A70	YES	6M	1"	1"

PRO VERSION ONLY



FUEL MANAGEMENT SYSTEMS



DISPENSERS



KITS



PUMPS



METERS



NOZZLES

# ST 200 AC

## FEATURES

- STURDY METALLIC FRAME
- READY TO USE
- EASY TO MOVE
- HEAVY DUTY

The PIUSI ST 200 AC is a dispenser that allows high flow refueling thanks to the two integrated E120 self-priming rotary electric vane pumps. Fitted with by-pass valve and elevated reliability seal, the dispenser works even at low working temperatures and in every condition on worksites. The oval gear mechanical flow meter guarantees great precision (available on request). It is also available with wheels and handle (on request) for easier handling.

### PERFORMANCE

UP TO  
**200 L/MIN**

FLOW RATE

**AC**  
CONTINUOUS DUTY

POWER



ST 200 AC



HANDY KIT: VERSION WITH WHEELS AND HANDLE

### PACKAGING

CODE	WEIGHT		PACKAGING		
	KG	LBS	MM	INCH	PCS/BOX
FO0315000	46	101	587X395X420	23,1X15,6X16,5	1
F16860000	-	-	-	-	-



FILTRATION



TANK MONITORING



HOSE REEL



ACCESSORIES



MERCHANDISE

# PIUSI

INDEX

B

ANY BIODIESEL

A

AIR

A

ANTIFREEZE

Ad

AdBlue®

B

BIODIESEL

D

DIESEL

F

FOOD

G

GASOLINE

G

GREASE

K

KEROSENE

O

OIL

W

WATER

W

WINDSCREEN

## CHART

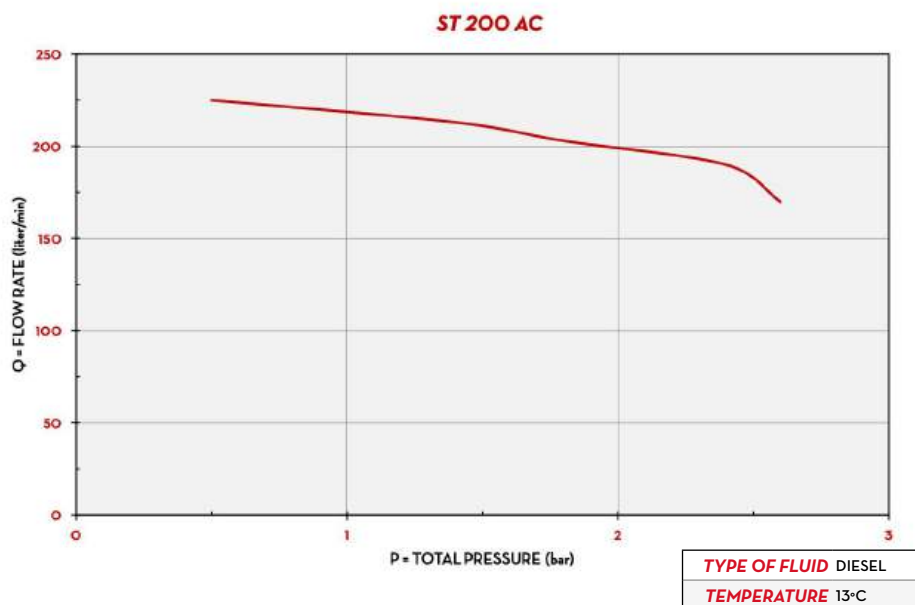

## IN THE BOX

- ST 200 AC UNIT
- INSTRUCTION MANUAL

## DETAILS



ON/OFF SWITCH

## DIMENSIONS

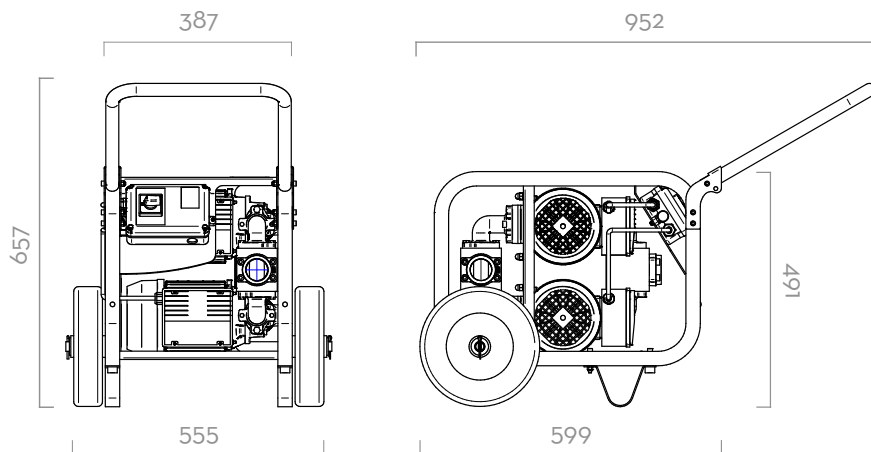

Dimensions expressed in millimeters

## MATERIALS

- BODY: CAST IRON
- ROTOR: SINTERED STEEL
- VANES: ACETAL RESIN
- SEAL: VITON
- SHAFT: STEEL

## TECHNICAL DATA

CODE	DESCRIPTION	FLUIDS TYPE	FLOW RATE		VOLTAGE			PUMP		MAX PRESSURE	OUTLET
			L/MIN	GPM	AC V/HZ DC VOLT	POWER WATT	AMP. MAX.	TYPE	N°	BAR	BSP
FO0315000	ST 200 BASIC	D	200	52,7	230/50	2050	10	E 120	2	2,5	1" 1/2
F16860000	HANDY KIT (HANDLE + WHEELS)	D	-	-	-	-	-	-	-	-	-



FUEL MANAGEMENT SYSTEMS



DISPENSERS



KITS



PUMPS



METERS



NOZZLES

# ST 200 DC

## FEATURES

- STURDY STRUCTURE
- COMPACT DESIGN
- READY TO USE
- HIGH RELIABILITY
- HEAVY DUTY

PIUSI ST 200 DC is a 24V portable dispensing unit for high flow applications. The low weight of the unit makes it easy to handle and suitable for operating on worksites in every condition; both on tanks or for mobile applications. Thanks to the mechanical meter K700, this sturdy dispenser guarantees the maximum precision (on request).

### PERFORMANCE

UP TO

**185 L/MIN**

FLOW RATE

**24V**  
VOLTAGE

POWER

**20 MIN**  
(40MIN OFF)

DUTY CYCLE



ST 200 DC



### PACKAGING

CODE	WEIGHT		PACKAGING		
	KG	LBS	MM	INCH	PCS/BOX
FO0318000	18	40	480X370X265	18,9X14,6X10,4	1



FILTRATION



TANK MONITORING



HOSE REEL



ACCESSORIES



MERCHANDISE

# PIUSI

INDEX

B

ANY BIODIESEL

A

AIR

A

ANTIFREEZE

Ad

AdBlue®

B

BIODIESEL

D

DIESEL

F

FOOD

G

GASOLINE

G

GREASE

K

KEROSENE

O

OIL

W

WATER

W

WINDSCREEN

## CHART

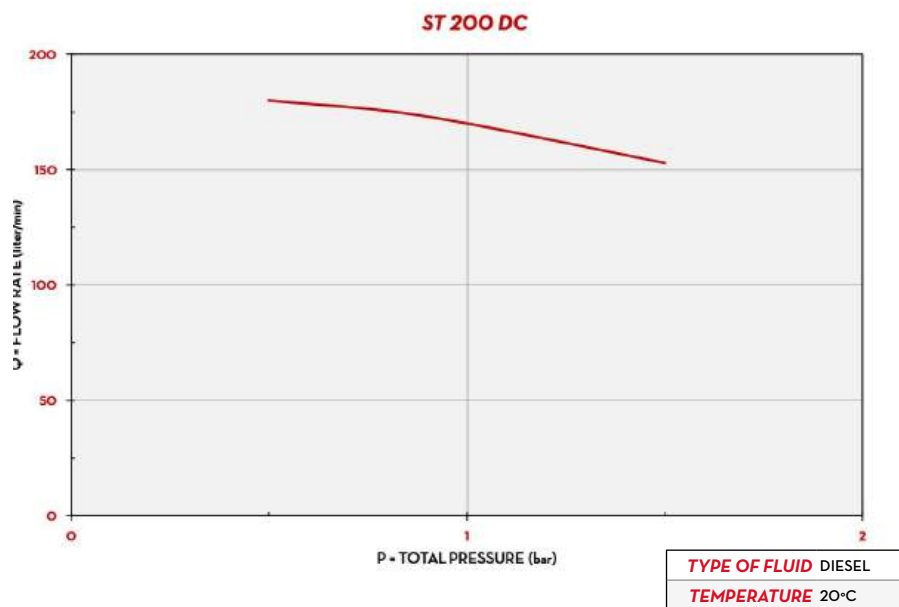

## IN THE BOX

- ST 200 DC UNIT
- ELECTRIC CABLE WITH CLAMPS
- INSTRUCTION MANUAL

## DETAILS



ON/OFF SWITCH

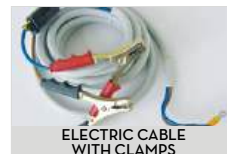

ELECTRIC CABLE WITH CLAMPS

## DIMENSIONS

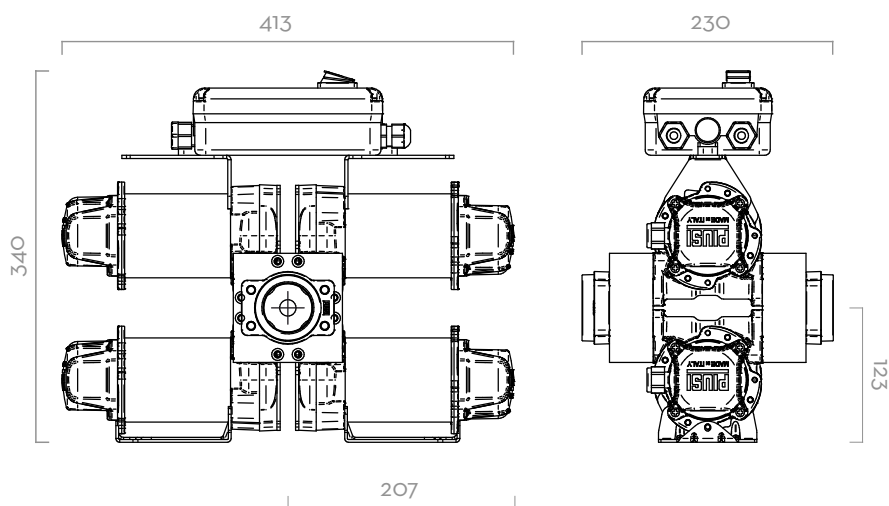

Dimensions expressed in millimeters

## MATERIALS

- BODY: CAST IRON
- ROTOR: SINTERED STEEL
- VANES: ACETAL RESIN
- SEAL: NBR
- SHAFT: STEEL

## TECHNICAL DATA



CODE	DESCRIPTION	FLUIDS TYPE	FLOW RATE		VOLTAGE			DUTY CICLE	PUMP		MAX PRESSURE	OUTLET
			L/MIN	GPM	AC V/HZ	DC VOLT	POWER WATT		AMP. MAX.	MINUTES		
FO0318000	ST 200 DC 24 V	D	185	42-48	24	1200	50	30	BYPASS 3000	4	2	1" 1/2



# KITS ACCESSORIES



## ATEX

EX50 DRUM	CODICE	DESCRIZIONE
	F1815600B	(EX) ADAPTER FOR CONDUIT EX50
	F1862600A	(EX)CABLE+CABLEGLAND ECEX EX50 12V
	F20305000	KIT ANTISIFONE EX50





F1815600B
F1862600A

EX100 DRUM	CODICE	DESCRIZIONE
	F21770000	BUNG ADAPTER 2" BSP COMPLETE
	F22436010	ANTISIPHONE KIT FOR EX100/EX140/E140 BSP
	F22053000	MOTOR SUPPORT FEET EX80/100/140

F22436010
F22053000
F21770000



EX140 DRUM	CODICE	DESCRIZIONE
	F21770000	BUNG ADAPTER 2" BSP COMPLETE
	F22436010	ANTISIPHONE KIT FOR EX100/EX140/E140 BSP
	F22053000	MOTOR SUPPORT FEET EX80/100/140





F22436010
F22053000
F21770000



EX50 ST	CODICE	DESCRIZIONE
	F1815600B	(EX) ADAPTER FOR CONDUIT EX50
	F1862600A	(EX)CABLE+CABLEGLAND ECEX EX50 12V

F1815600B
F1862600A



## MOBILE

BATTERIA KIT	CODICE	DESCRIZIONE
	F16586000	DRUM 3000 KIT
	F16631000	KIT DRUM 3000 K33 / FILTER / ADAPTER

F16586000
F16631000

PIUSIBOX	CODICE	DESCRIZIONE
	F16483010	CARTUCCIA 10 MICRON 3/4IN PIUSI BOX 15PC
	R20764000	K24 ASSEMBLY KIT FOR PIUSIBOX N.







R20764000
F16483010







## ST

ST BOX	CODE	DESCRIPTION
	F1249600A	MANAGER KEY 2018
	F1590400A	KIT DRIVER KEY YELLOW (10PCS)
	F17121000	LEVEL PROBE FOR ACCESS 85
	F1721800A	ST BOX NEW







F17121000
F1249600A
F1590400A

ST 200 AC	CODE	DESCRIPTION
	F16860000	KIT WHEELS \ HANDLE ST200
	F18798000	KIT HOSE 1 1/2" 10 MT+CAMLOCK+HOSETAIL
	F18799000	KIT HOSE 1 1/2" 20 MT+CAMLOCK+HOSETAIL

F18798000
F18799000
F16860000

ST 200 DC	CODE	DESCRIPTION
	F18798000	KIT HOSE 1 1/2" 10 MT+CAMLOCK+HOSETAIL
	F18799000	KIT HOSE 1 1/2" 20 MT+CAMLOCK+HOSETAIL

F18798000
F18799000



# **PUMPS**



FUEL MANAGEMENT SYSTEMS



DISPENSERS



KITS



PUMPS



METERS



NOZZLES

# EX100

## FEATURES

- HIGH FLOW RATE
- HEAVY DUTY
- CONTINUOUS DUTY
- THERMAL PROTECTION
- UL VERSION AVAILABLE
- REMOVABLE PUMP FEET

PIUSI EX100 is the new pump of the EX line, suitable for the transfer of gasoline and diesel with high performance and continuous duty. The directive on the use of materials in potentially explosive atmospheres is very precise, as confirmed by the ATEX certification. Simple to use, compact, versatile, it performs high flow rate and continuous duty cycle.

### PERFORMANCE

UP TO  
**100 L/MIN**

FLOW RATE

**AC**  
VOLTAGE

POWER



EX100

OUR PUMPS COMPLIES WITH THE FOLLOWING MARKING ATEX/IECEX

II	2	G	Ex	d	IIA	T4	Gb
GROUP	CATEGORY	TYPE OF EXPLOSIVE ATMOSPHERE	PERMANENT PREFIX	PROTECTION METHOD	GAS GLASS	TEMPERATURE CLASS	EQUIPMENT PROTECTION LEVEL

### PACKAGING

CODE	WEIGHT		PACKAGING		
	KG	LBS	MM	INCH	PCS/BOX
FO0390010	25	55	240X400X350	9,4X15,7X13,8	1
FO0390020	25	55	240X400X350	9,4X15,7X13,8	1
FO0390030	25	55	240X400X350	9,4X15,7X13,8	1



FILTRATION



TANK MONITORING



HOSE REEL



ACCESSORIES



MERCHANDISE

# PIUSI

INDEX

B

ANY BIODIESEL

A

AIR

A

ANTIFREEZE

Ad

AdBlue®

B

BIODIESEL

D

DIESEL

F

FOOD

G

GASOLINE

G

GREASE

K

KEROSENE

O

OIL

W

WATER

W

WINDSCREEN

### CHART

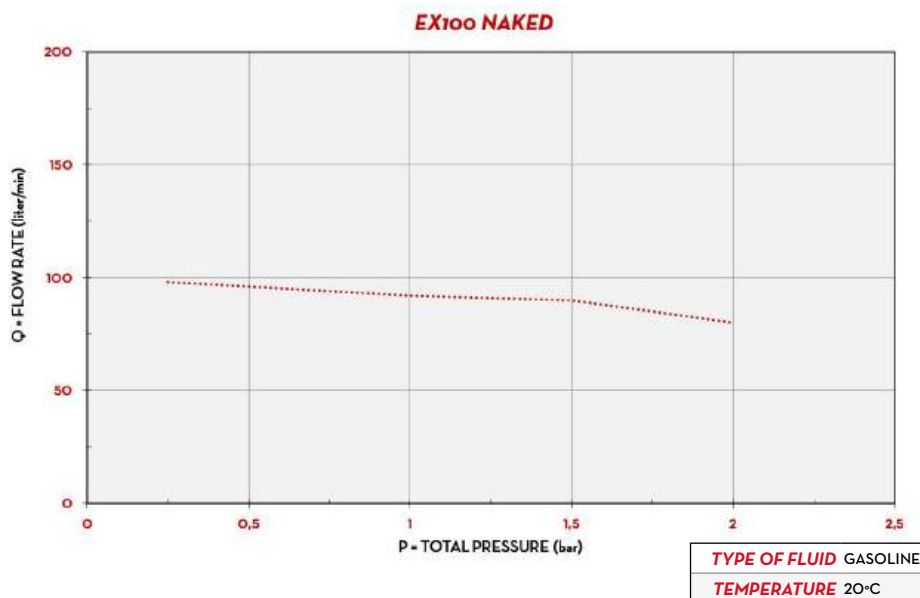

### DIMENSIONS

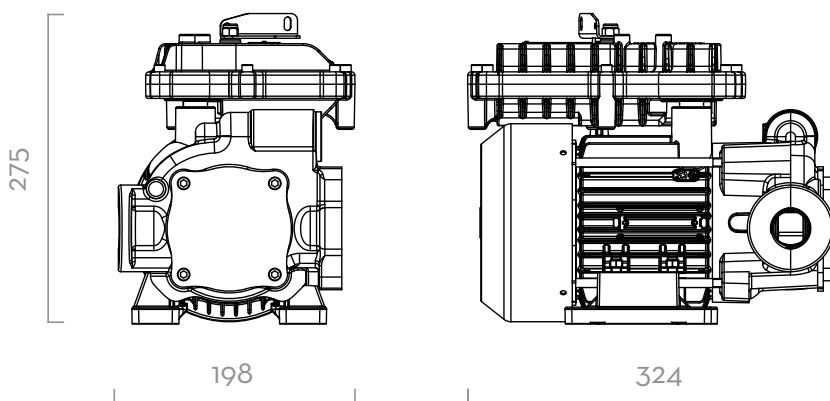

Dimensions expressed in millimeters

### IN THE BOX

- EX100 PUMP
- PUMP FEET
- INSTRUCTION MANUAL

### DETAILS



ON/OFF SWITCH



VANE ROTOR



BYPASS VALVE

### MATERIALS

- BODY: CAST IRON
- ROTOR: SINTERED STEEL
- VANES: TECHNOPOLYMER
- SEAL: VITON
- SHAFT: STEEL



PUMP

- > MAX 6M (20FT),
- > SUCTION HOSE Ø 1" MIN,
- > MAX SUCTION HEIGHT:
  - 2M (7FT) W/O NON RETURN VALVE
  - 4M (14FT) W NON RETURN VALVE



TANK

### TECHNICAL DATA

CODE	DESCRIPTION	FLUIDS TYPE	FLOW RATE		VOLTAGE			DUTY CICLE	RPM	INLET		OUTLET	
			L/MIN	GPM	AC VOLT/HZ	POWER WATT	AMP. MAX.			CONTINUOUS	BSP	BSP	
FO0390010	EX 100 230/50 ATEX	D G K	100	25	230/50	1035	4,5	YES	1450	1" 1/4	1"		
FO0390020	EX 100 230/60 ATEX	D G K	100	25	230/60	874	3,8	YES	1750	1" 1/4	1"		
FO0390030	EX 100 250/50 ATEX	D G K	100	25	250/50	1000	3,8	YES	1450	1" 1/4	1"		

( ) UPON REQUEST IT IS AVAILABLE WITH DIFFERENT VOLTAGES AND 60 HZ FREQUENCY. THE PUMP CAN BE USED ONLY WITH THE FOLLOWING FLUIDS: DIESEL, KEROSENE, PETROL, PETROL ALCOHOL MIXED MAX 15%, AVGAS 100/100LL, JET A/A1 - ASPEN 2/4



FUEL MANAGEMENT SYSTEMS



DISPENSERS



KITS



PUMPS



METERS



NOZZLES

# EX140



## FEATURES

- HIGH FLOW RATE
- HEAVY DUTY
- CONTINUOUS DUTY
- THERMAL PROTECTION
- UL VERSION AVAILABLE
- REMOVABLE PUMP FEET

The entirely new EX line is characterized by a high flow rate that works with a continuous duty cycle, and has been designed to be particularly suitable for Heavy Duty, i.e. for those demanding fleets that need to dispense fuels such as Gasoline, diesel or kerosene quickly.

### PERFORMANCE

UP TO  
**140 L/MIN**

FLOW RATE

**AC**  
VOLTAGE

POWER



EX140

OUR PUMPS COMPLIES WITH THE FOLLOWING MARKING ATEX/IECEX

II	2	G	Ex	d	IIA	T4	Gb
GROUP	CATEGORY	TYPE OF EXPLOSIVE ATMOSPHERE	PERMANENT PREFIX	PROTECTION METHOD	GAS GLASS	TEMPERATURE CLASS	EQUIPMENT PROTECTION LEVEL
II	2	G	Ex	d	IIA	T4	Gb

### PACKAGING

CODE	WEIGHT		PACKAGING		
	KG	LBS	MM	INCH	PCS/BOX
FO0395010	25	55	240X400X350	9,4X15,7X13,8	1
FO0395020	25	55	240X400X350	9,4X15,7X13,8	1
FO0395030	25	55	240X400X350	9,4X15,7X13,8	1



FILTRATION



TANK MONITORING



HOSE REEL



ACCESSORIES



MERCHANDISE

# PIUSI

INDEX

B

ANY BIODIESEL

A

AIR

A

ANTIFREEZE

Ad

AdBlue®

B

BIODIESEL

D

DIESEL

F

FOOD

G

GASOLINE

G

GREASE

K

KEROSENE

O

OIL

W

WATER

W

WINDSCREEN

## CHART

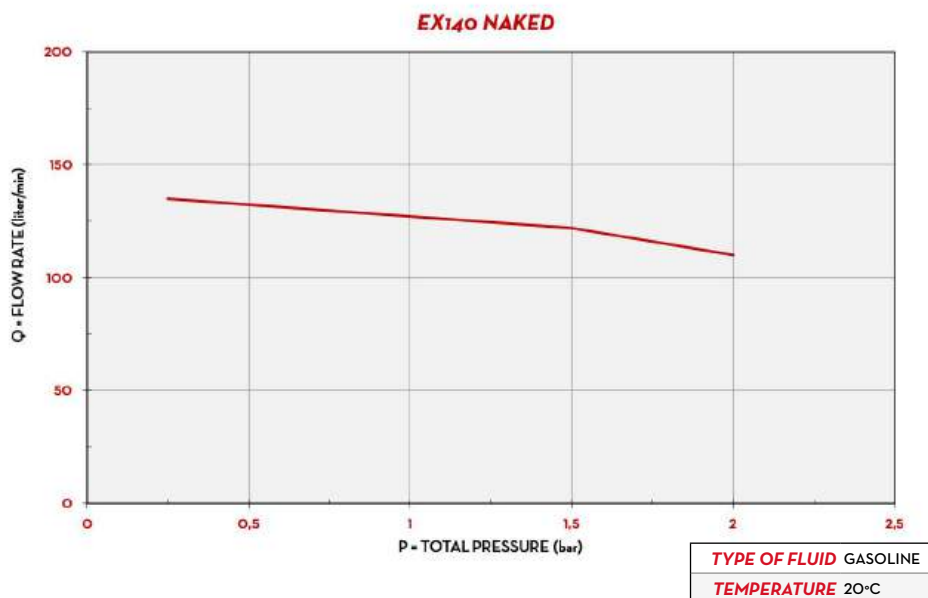

## DIMENSIONS

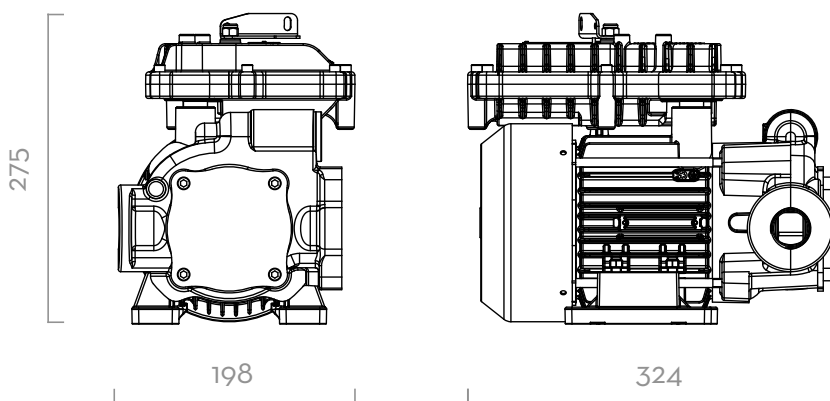

Dimensions expressed in millimeters

## IN THE BOX

- EX140 PUMP
- PUMP FEET
- INSTRUCTION MANUAL

## DETAILS



ON/OFF SWITCH



VANE ROTOR



BYPASS VALVE

## MATERIALS

- BODY: CAST IRON
- ROTOR: SINTERED STEEL
- VANES: TECHNOPOLYMER
- SEAL: VITON
- SHAFT: STEEL



PUMP

- > MAX 6M (20FT),
- > SUCTION HOSE Ø 1" MIN,
- > MAX SUCTION HEIGHT:
  - 2M (7FT) W/O NON RETURN VALVE
  - 4M (14FT) W NON RETURN VALVE



TANK

## TECHNICAL DATA

CODE	DESCRIPTION	FLUIDS TYPE	FLOW RATE		VOLTAGE			DUTY CICLE	RPM	INLET		OUTLET	
			L/MIN	GPM	AC VOLT/HZ	POWER WATT	AMP. MAX.			CONTINUOUS	BSP	BSP	
FO0395010	EX 140 230/50	D G K	140	37	230/50	1150	5	YES	1450	1" 1/4	1"		
FO0395020	EX 140 250/50	D G K	140	37	250/50	1125	4,5	YES	1450	1" 1/4	1"		
FO0395030	EX 140 230/60	D G K	140	37	230/60	920	4	YES	1750	1" 1/4	1"		

( ) UPON REQUEST IT IS AVAILABLE WITH DIFFERENT VOLTAGES AND 60 HZ FREQUENCY. THE PUMP CAN BE USED ONLY WITH THE FOLLOWING FLUIDS: DIESEL, KEROSENE, PETROL, PETROL ALCOHOL MIXED MAX 15%, AVGAS 100/100LL, JET A/A1 - ASPEN 2/4



FUEL MANAGEMENT SYSTEMS



DISPENSERS



KITS



PUMPS



METERS



NOZZLES

# EX50 / EX75 DC

## FEATURES

- COMPACT AND STURDY DESIGN
- FLANGED COMPONENTS
- ANTI-NOISE FILTER
- THERMAL PROTECTION
- SUCTION UNIT WITH INTEGRATED FILTER (DRUM VERSION)
- UL LISTED MOTOR AVAILABLE

The PIUSI EX50/EX75 DC is a transfer pump suitable for flammable fuels such as petrol, kerosene and diesel. It is fully compliant with ATEX/IECEX requirements for the usage in potentially explosive atmospheres. Designed to transfer flammable fluids from tanks of any type, this pump is available in DC version and is fitted with a bypass valve and can dispense up to 75 l/min, with reduced absorption to ensure a long life to the pump.

### PERFORMANCE

UP TO

**75 L/MIN**

FLOW RATE

**DC 12V**

VOLTAGE

POWER

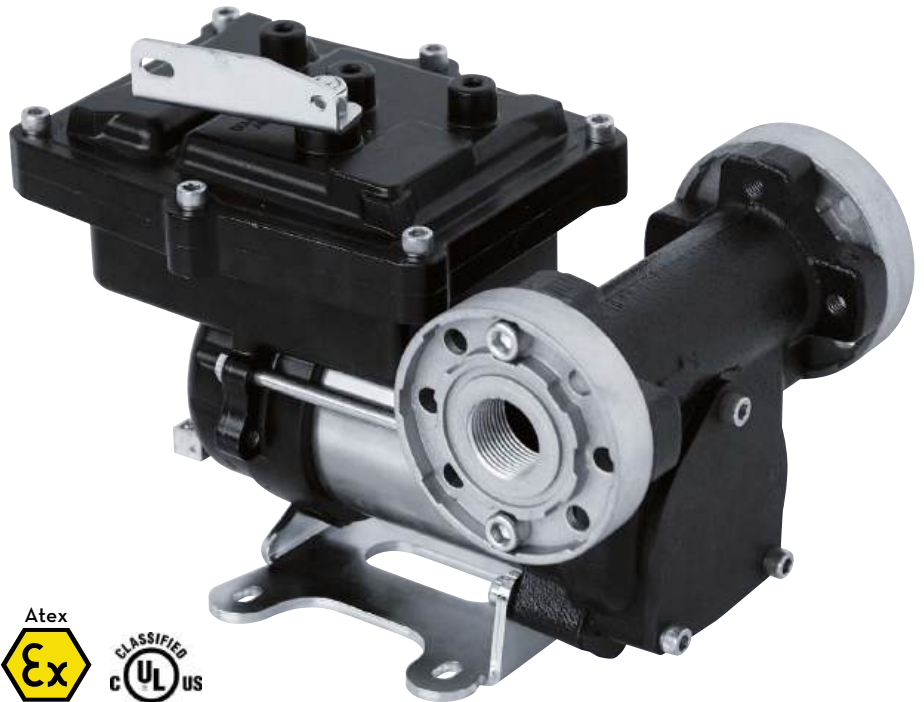



EX75 DC



OUR PUMPS COMPLIES WITH THE FOLLOWING MARKING ATEX/IECEX

II	2	G	Ex	d	db	IIA	IIB	T4	Gb
GROUP	CATEGORY	TYPE OF EXPLOSIVE ATMOSPHERE	PERMANENT PREFIX	PROTECTION METHOD		GAS GLASS		TEMPERATURE CLASS	EQUIPMENT PROTECTION LEVEL
						EX50	EX75	EX50	EX75

### PACKAGING

CODE	WEIGHT		PACKAGING			N. BOXES / EUROPALLET	
	KG	LBS	MM	INCH	PCS/BOX		
FO0371000	6,9	15,2	345X175X225	-	1	60	84
FO0380000	8	17,8	350X185X260	-	1	60	84





FILTRATION



TANK MONITORING



HOSE REEL



ACCESSORIES



MERCHANDISE

# PIUSI

INDEX

B

ANY BIODIESEL

A

AIR

A

ANTIFREEZE

Ad

AdBlue®

B

BIODIESEL

D

DIESEL

F

FOOD

G

GASOLINE

G

GREASE

K

KEROSENE

O

OIL

W

WATER

W

WINDSCREEN

### CHART

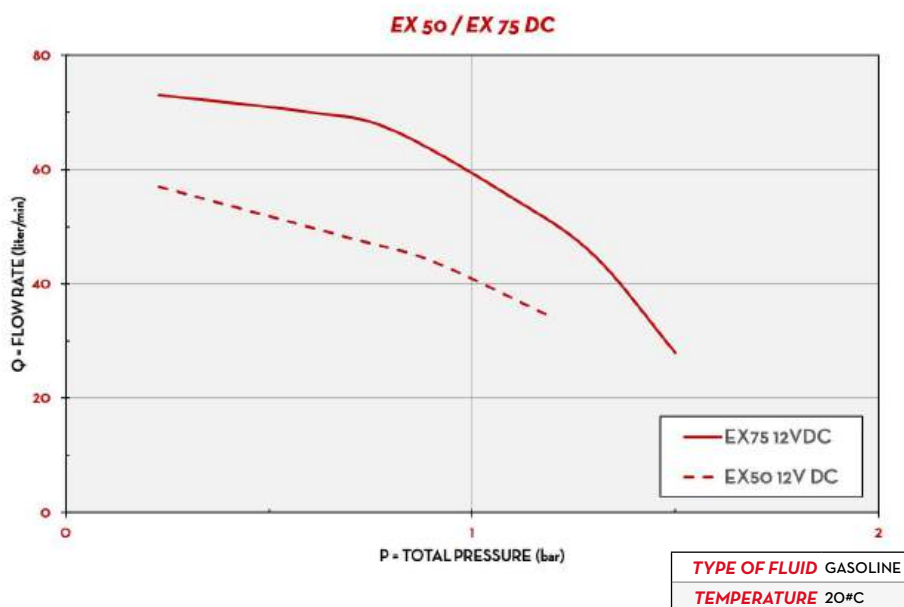

### IN THE BOX

- EX50 / EX75 DC PUMP
- FLANGED CONNECTIONS
- INSTRUCTION MANUAL

### DETAILS



ON/OFF SWITCH



FLANGED CONNECTIONS

### DIMENSIONS

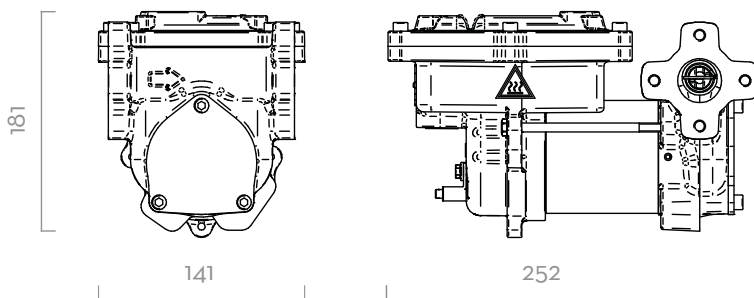

Dimensions expressed in millimeters

### MATERIALS

- BODY: CAST IRON
- ROTOR: SINTERED STEEL
- VANES: PPS
- SEAL: VITON
- SHAFT: STEEL



PUMP

- > MAX 6M (20FT),
- > SUCTION HOSE Ø 1" MIN,
- > MAX SUCTION HEIGHT:
  - 2M (7FT) W/O NON RETURN VALVE
  - 4M (14FT) W NON RETURN VALVE



TANK

### TECHNICAL DATA

CODE	DESCRIPTION	FLUIDS TYPE	FLOW RATE		VOLTAGE			DUTY CYCLE	RPM	OUTLET
			L/MIN	GPM	AC VOLT/HZ	POWER WATT	AMP. MAX.	MINUTES		BSP
FO0371000	EX50 12V DC ATEX	D G K	50	13	12	250	21	30	2700	1"
FO0380000	EX75 12V DC ATEX	D G K	75	19,8	12	240	20	30	2700	1"

( ) UPON REQUEST IT IS AVAILABLE WITH DIFFERENT VOLTAGES AND 60 HZ FREQUENCY. THE PUMP CAN BE USED ONLY WITH THE FOLLOWING FLUIDS: DIESEL, KEROSENE, PETROL, PETROL ALCOHOL MIXED MAX 15%, AVGAS 100/100LL, JET A/A1 - ASPEN 2/4



FUEL MANAGEMENT SYSTEMS



DISPENSERS



KITS



PUMPS



METERS



NOZZLES

# EXGO!

## FEATURES

- CONTINUOUS DUTY
- COMPACT AND STURDY DESIGN
- EASY TO INSTALL
- BUILT-IN BYPASS
- THERMAL PROTECTION
- REDUCED NOISE LEVEL
- SELF-PRIMING

The PIUSI EX GO! is a compact and sturdy ATEX vane pump; expressly engineered to work safely in potentially explosives atmosphere. As the name says, this continuous duty DC pump is easy to place thanks to the small sizes and represents the ideal solution for small mobile tanks thanks to the remote control (on/off switch) and long cables (5mt EXGO! Switch - 3mt EXGO! without Switch). It can be used to dispense several fluids: Gasoline and E15, Diesel, Paraffinic Biodiesel. It is equipped with built-in bypass valve and a thermal protected motor.

### PERFORMANCE

UP TO  
**32 L/MIN**

FLOW RATE

MAX  
**1,2 BAR**

OPERATING PRESSURE

**DC 12V**  
VOLTAGE  
POWER

**CONTINUOUS  
DUTY**



EXGO!



EXGO! BATTERY KIT



OUR PUMPS COMPLIES WITH THE FOLLOWING MARKING ATEX/IECEx  
EX50 EX75 EX50 EX75

II	2	G	Ex	d	db	IIA	IIB	T4	Gb
GROUP	CATEGORY	TYPE OF EXPLOSIVE ATMOSPHERE	PERMANENT PREFIX	PROTECTION METHOD		GAS GLASS		TEMPERATURE CLASS	EQUIPMENT PROTECTION LEVEL

### PACKAGING

CODE	WEIGHT		PACKAGING			N. BOX / EUROPALLET	
	KG	LBS	MM	INCH	PCS/BOX		
FO0381020	5,43	12	280X160X140	-	1	-	-
FO0381500	5,43	12	280X160X140	-	1	-	-
FO0225X00	9,8	21,6	350X350X180	-	1	H	



FILTRATION



TANK MONITORING



HOSE REEL



ACCESSORIES



MERCHANDISE

# PIUSI

INDEX

B

ANY BIODIESEL

A

AIR

A

ANTIFREEZE

Ad

AdBlue®

B

BIODIESEL

D

DIESEL

F

FOOD

G

GASOLINE

G

GREASE

K

KEROSENE

O

OIL

W

WATER

W

WINDSCREEN

## CHART

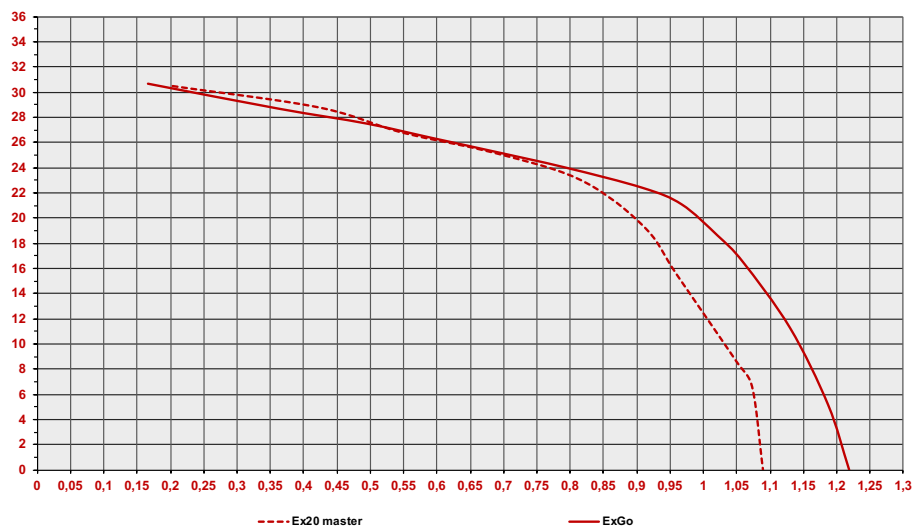

## DIMENSIONS

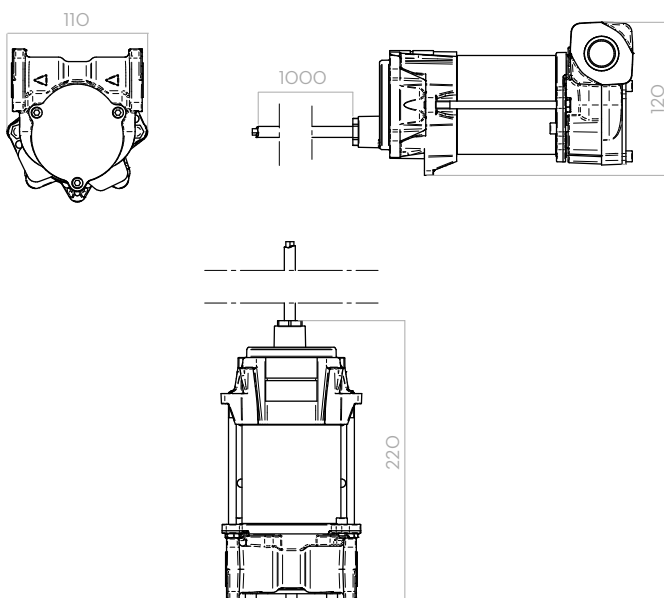

Dimensions expressed in millimeters

## IN THE BOX

- EXGO! PUMP/EXGO BATTERY KIT
- DELIVERY HOSE 2,5 MT (ONLY EXGO BATTERY KIT)
- SELF2000 NOZZLE (ONLY EXGO BATTERY KIT)
- INSTRUCTION MANUAL

## DETAILS



BUILT-IN BY-PASS VALVE



SWITCH ON/OFF



ELECTRIC CABLE WITH CLAMPS



SELF 2000 NOZZLE WITH DELIVERY HOSE 2.5M ONLY EXGO BATTERY KIT

## MATERIALS

- BODY: CAST IRON
- ROTOR: SINTERED STEEL
- VANES: PPS
- SEAL: FKM
- SHAFT: STEEL

## TECHNICAL DATA

CODE	DESCRIPTION	FLUIDS TYPE	FLOWRATE		VOLTAGE			FUSIBLES	DUTY CYCLE	NOZZLE	RPM	HOSE		IN	OUT	CHECK FILTER
			L/MIN	GPM	DC VOLT	POWER WATT	AMP. MAX.					AMPERE	MINUTE			
FO0381020	EXGO! 12V DC ATEX	B D G K	32	8,5	12	108	9A	25A	CONTINUOUS	-	1400	-	-	3/4"	3/4"	-
FO0381500	(EX) EX20 12V DC (W/O SWITCH)	B D G K	32	8,5	12	108	9A	25A	CONTINUOUS	-	1400	-	-	3/4"	3/4"	-
FO0225X00	EXGO BATTERY KIT	B D G K	32	8,5	12	108	9A	25A	CONTINUOUS	SELF 2000	1400	2,5M	3/4"	3/4"	3/4"	SI



FUEL MANAGEMENT SYSTEMS



DISPENSERS



KITS



PUMPS



METERS



NOZZLES

# PANTHER AC

## FEATURES

- COMPACT AND STURDY DESIGN
- READY TO USE
- EASY TO INSTALL
- INTEGRATED FILTER

The PIUSI PANTHER AC is a versatile self-priming rotary electric vane transfer pump available in three versions (56 - 72 - 90) particularly suitable for dispensers, fixed fuel transferring system and other industrial applications. It is equipped with a by-pass valve and an incorporated filter to stop impurities.

### PERFORMANCE

UP TO

**90 L/MIN**

FLOW RATE

**AC**

**CONTINUOUS DUTY\***

POWER



**PANTHER 56** (flanges not included)

**PANTHER 72 - PANTHER 90** (flanges included)



**PANTHER 72 BIO**



### PACKAGING

CODE	WEIGHT		PACKAGING			N. BOXES / EUROPALLET	
	KG	LBS	MM	INCH	PCS/BOX		
<b>PANTHER 56</b>							
FO0730000	7,4	16,3	345X175X255	-	1	60	84
000731000	7,4	16,3	345X175X255	-	1	60	84
000733000	7,4	16,3	345X175X255	-	1	60	84
<b>PANTHER 72</b>							
000732000	7,9	17,4	345X175X255	-	1	60	84
000735000	7,9	17,4	345X175X255	-	1	60	84
FO0732B00	7,9	17,4	345X175X255	-	1	60	84
<b>PANTHER 90</b>							
FO073302A	9,007	19,9	345X175X255	-	1	60	84

The electric motor is exempted from Energy Efficiency Regulation (EU) 2019/1781 in accordance to Article 2(2)(a).



FILTRATION



TANK MONITORING



HOSE REEL



ACCESSORIES



MERCHANDISE



ANY BIODIESEL



AIR



ANTIFREEZE



AdBlue®



BIODIESEL



DIESEL



FOOD



GASOLINE



GREASE



KEROSENE



OIL



WATER



WINDSCREEN

### CHART

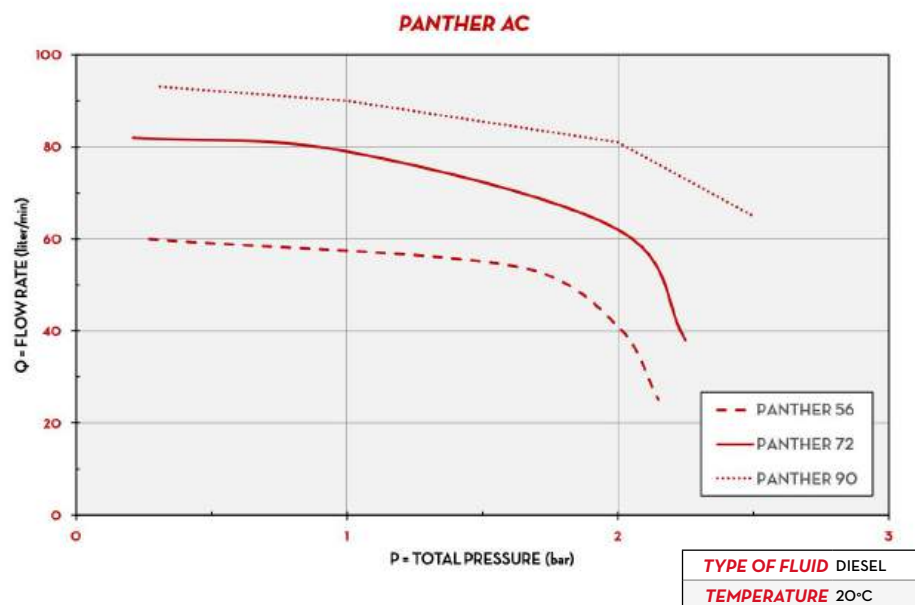

### IN THE BOX

- PANTHER AC PUMP
- INSTRUCTION MANUAL

### DETAILS



VANE ROTOR

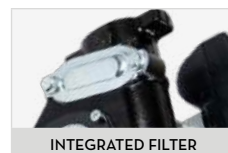

INTEGRATED FILTER

### DIMENSIONS

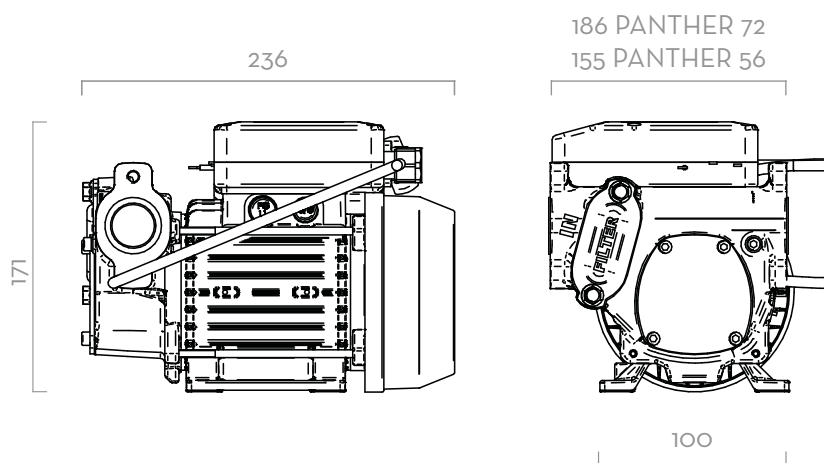

Dimensions expressed in millimeters

### MATERIALS

- BODY: CAST IRON
- ROTOR: SINTERED STEEL
- VANES: TECHNOPOLYMER
- SHAFT: STEEL



PUMP



TANK

- MAX 6M (20FT),
- SUCTION HOSE Ø 1" MIN,
- MAX SUCTION HEIGHT:
- 2M (7FT) W/O NON RETURN VALVE
- 4M (14FT) W NON RETURN VALVE

### TECHNICAL DATA

CODE	DESCRIPTION	FLUIDS TYPE	FLOW RATE		VOLTAGE				RPM	INLET OUTLET BSP	FLANGE CON- NECTION	BYPASS VALVE	INLET FILTER	DUTY CYCLE MINUTE
			L/MIN	GPM	SINGLEPHASE MOTOR V./HZ	THREEPHASE MOTOR V./HZ	POWER WATT	AMP. MAX.						
<b>PANTHER 56</b>														
FO0730000	PANTHER 56 230/50	D	56	15	230/50	-	350	3	2900	1"	-	YES	YES	
000731000	PANTHER 56 230/60	D	70	18	230/60	-	500	3,9	3400	1"	-	YES	YES	
000733000	PANTHER 56 400/50	D	56	15	-	400/50	500	1,3	2900	1"	-	YES	YES	
<b>PANTHER 72</b>														
000732000	PANTHER 72 230/50	D	72	19	230/50	-	500	4,2	2900	1"	YES	YES	YES	
000735000	PANTHER 72 400/50	D	72	19	-	400/50	500	1,6	2900	1"	YES	YES	YES	
FO0732B00	PANTHER 72 230V/50HZ B100	B D	72	19	230/50	-	500	4,2	2900	1"	YES	YES	YES	
<b>PANTHER 90</b>														
FO073302A	PANTHER 90 230/50	D	90	23,8	230/50	-	700	4,9	2900	1"	YES	YES	YES	30

UPON REQUEST IT IS AVAILABLE WITH DIFFERENT VOLTAGES AND 60 HZ FREQUENCY.  
(\* ) EXCEPT PANTHER 90



FUEL MANAGEMENT SYSTEMS



DISPENSERS



KITS



PUMPS



METERS



NOZZLES

# VISCOMAT VANE

## FEATURES

- VERSATILITY
- MOBILE AND READY TO USE
- MULTIPURPOSE PUMP
- ADJUSTABLE BYPASS

The PIUSI VISCOMAT VANE is an electric vane pump suitable for all those applications where it is necessary to apply a transfer system with high suction capacity in order to transfer fluids with low viscosity up to 500 cSt. The pump is fitted with an asynchronous and self-ventilating motor, closed and available in different voltages and frequencies in order to adapt to any working condition.

### PERFORMANCE

UP TO

**50 L/MIN**

FLOW RATE

**AC**

**CONTINUOUS DUTY**

POWER

UP TO

**500 CST**

VISCOSITY



VISCOMAT VANE



### PACKAGING

CODE	WEIGHT		PACKAGING			N. BOXES / EUROPALLET	
	KG	LBS	MM	INCH	PCS/BOX	✈	🚚
<b>VISCOMAT 70</b>							
FO033490A	14,1	31,1	355X185X285	-	1	60	72
FO033190A	14,1	31,1	350X200X280	-	1	60	72
<b>VISCOMAT 90</b>							
FO0303M00	14,1	31,1	350X200X280	-	1	60	72
000303000	14,1	31,1	350X200X280	-	1	60	72

The electric motor is exempted from Energy Efficiency Regulation (EU) 2019/1781 in accordance to Article 2(2)(a).



FILTRATION



TANK MONITORING



HOSE REEL



ACCESSORIES



MERCHANDISE

# PIUSI

INDEX

B

ANY BIODIESEL

A

AIR

A

ANTIFREEZE

Ad

AdBlue®

B

BIODIESEL

D

DIESEL

F

FOOD

G

GASOLINE

G

GREASE

K

KEROSENE

O

OIL

W

WATER

W

WINDSCREEN

## CHART

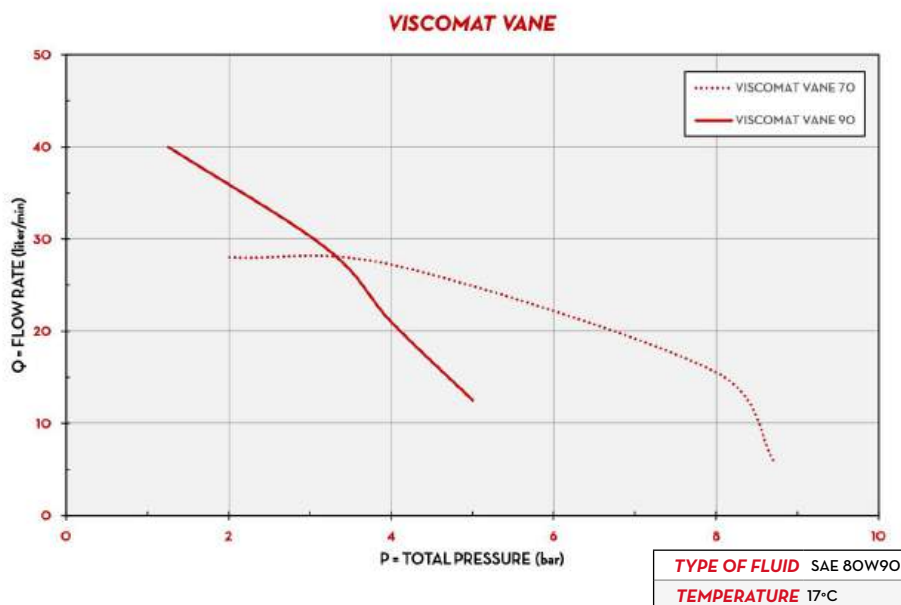

## DIMENSIONS

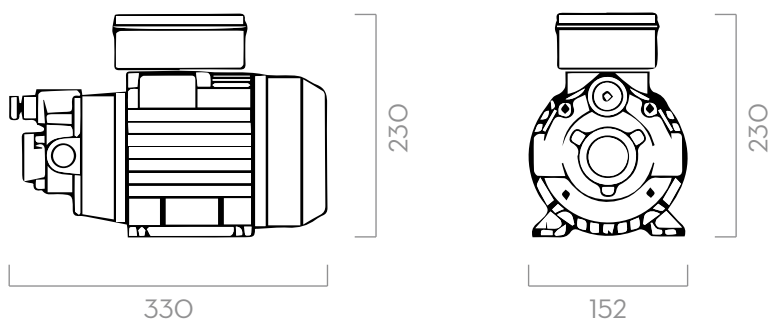

Dimensions expressed in millimeters

## IN THE BOX

- VISCOMAT VANE PUMP
- INSTRUCTION MANUAL

## DETAILS



ON/OFF SWITCH

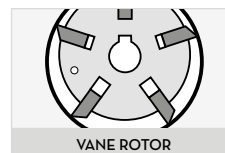

VANE ROTOR



ADJUSTABLE BYPASS VALVE

## MATERIALS

- BODY: CAST IRON
- ROTOR: SINTERED STEEL
- VANES: TECHNOPOLYMER
- SHAFT: STEEL



PUMP

- SUCTION HOSE Ø 1" MIN,
- MAX SUCTION HEIGHT:
  - 2M (7FT) W/O NO BACK VALVE
  - 4M (14FT) W NO BACK VALVE



TANK

## TECHNICAL DATA

CODE	DESCRIPTION	FLUIDS TYPE	FLOW RATE		PRESSURE		VOLTAGE				RPM	INLET/OUTLET		ADJUSTABLE BYPASS VALVE
			L/MIN	GPM	BAR	PSI	SINGLEPHASE MOTOR V./HZ	THREEPHASE MOTOR V./HZ	POWER WATT	AMP. MAX.		BSP		
<b>VISCOMAT 70</b>														
FO033490A	VISCOMAT 70 M 230/50-60	D O B	25	7	6	85	230/50-60	-	1200/1100	5,5 - 5,1	1470/1650	1"	YES	
FO033190A	VISCOMAT 70 T 400/50-60	D O B	25	7	6	85	-	400/50 - 400/60	650/1000	2,2 - 3,1	1450/1750	1"	YES	
<b>VISCOMAT 90</b>														
FO0303M00	VISCOMAT 90 M 230/50-60	D O B	50	13	5	71	230/50-60	-	1350/1600	6,2 - 4,9	1400/1600	1"	NO	
000303000	VISCOMAT 90 T 400/50	D O B	50	13	5	71	-	400/50	2000	5	1450	1"	YES	

UPON REQUEST IT IS AVAILABLE WITH DIFFERENT VOLTAGE AND FREQUENCY



FUEL MANAGEMENT SYSTEMS



DISPENSERS



KITS



PUMPS



METERS



NOZZLES

# E80 / E120

## FEATURES

- VERSATILITY
- STURDY STRUCTURE
- LONG LASTING
- REASY TO USE
- THERMAL PROTECTION

The PIUSI E80 and E120 are self-priming rotary electric vane pumps, compact and easy to install, suitable to meet all those use requirements needing a high-performance and long lasting product. The sturdy structure along with the thermal protection and the top-quality components allow its use at low working temperatures.

### PERFORMANCE

UP TO

**100 L/MIN**

FLOW RATE

**AC**

**CONTINUOUS DUTY**

POWER



E80/E120



E120 BIO

### PACKAGING

CODE	WEIGHT		PACKAGING			N. BOXES / EUROPALLET	
	KG	LBS	MM	INCH	PCS/BOX	✕	
<b>E80</b>							
000305000	10,26	22,6	355X185X285	-	1	60	72
000307000	10,26	22,6	355X185X285	-	1	60	72
<b>E120</b>							
000326000	13,25	29,2	355X185X285	-	1	60	72
000312000	13,25	29,2	355X185X285	-	1	60	72
FO0326B00	13,25	29,2	355X185X285	-	1	60	72

The electric motor is exempted from Energy Efficiency Regulation (EU) 2019/1781 in accordance to Article 2(2)(a).





FILTRATION



TANK MONITORING



HOSE REEL



ACCESSORIES



MERCHANDISE



ANY BIODIESEL



AIR



ANTIFREEZE



AdBlue®



BIODIESEL



DIESEL



FOOD



GASOLINE



GREASE



KEROSENE



OIL



WATER



WINDSCREEN

### CHART

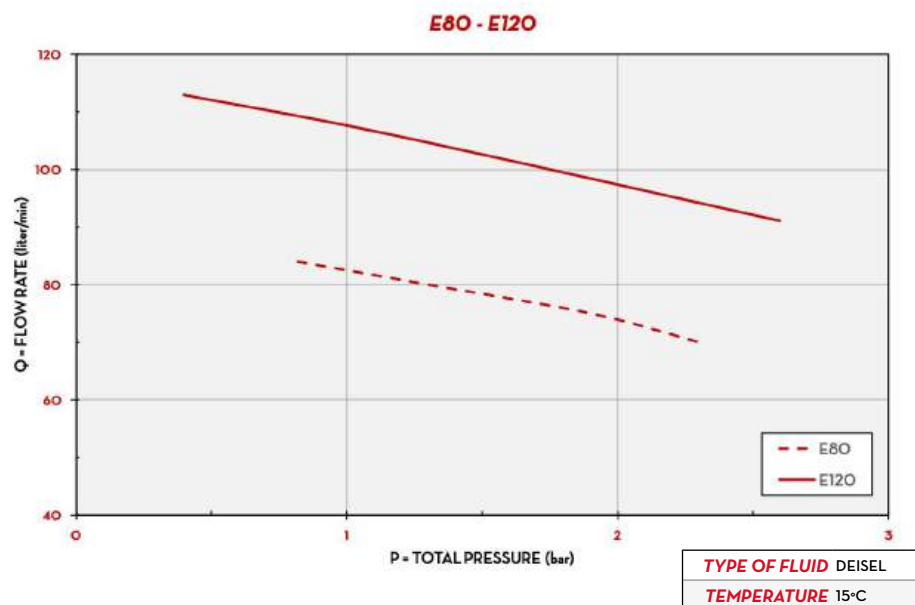

### IN THE BOX

- E80/E120 PUMP
- FLANGED CONNECTION
- INSTRUCTION MANUAL

### DETAILS



VANE ROTOR



FLANGED CONNECTION

### DIMENSIONS

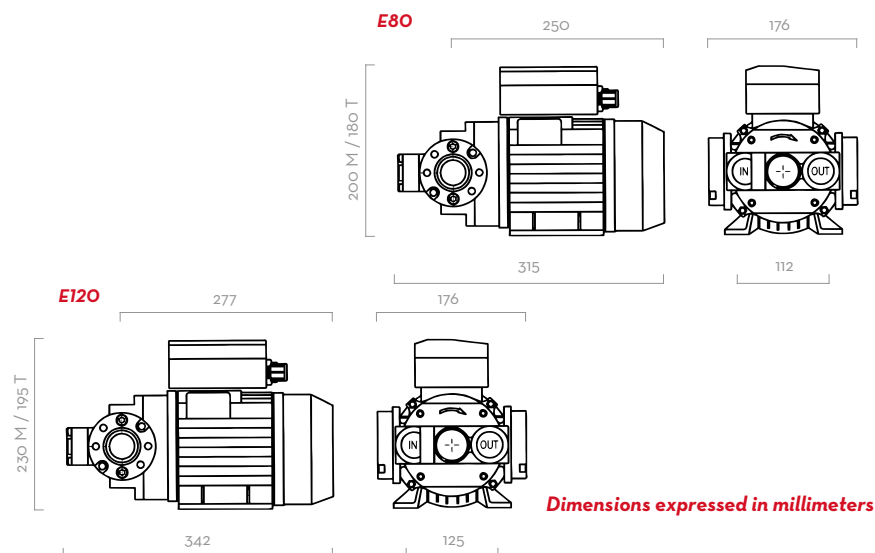

### MATERIALS

- BODY: CAST IRON
- ROTOR: SINTERED STEEL
- VANES: ACETAL RESIN
- SEAL: VITON
- SHAFT: STEEL



PUMP

- > MAX 6M (20FT),
- > SUCTION HOSE Ø 1" MIN,
- > MAX SUCTION HEIGHT:
  - 2M (7FT) W/O NON RETURN VALVE
  - 4M (14FT) W NON RETURN VALVE



TANK

### TECHNICAL DATA

CODE	DESCRIPTION	FLUIDS TYPE	FLOW RATE		VOLTAGE				RPM	INLET OUTLET		FLANGE CONNECTION	BYPASS VALVE	INLET FILTER
			L/MIN	GPM	SINGLEPHASE MOTOR V/HZ	THREEPHASE MOTOR V/HZ	POWER WATT	AMP. MAX.		BSP				
<b>E 80</b>														
000305000	E 80 M	D	70	18	230/50	-	500	3,5	1400	1"	YES	YES	NO	
000307000	E 80 T	D	70	18	-	400/50	550	1,6	1450	1"	YES	YES	NO	
<b>E 120</b>														
000326000	E 120 M	D	100	26	230/50	-	750	5,7	1450	1"	YES	YES	NO	
000312000	E 120 T	D	100	26	-	400/50 460/60	750 - 1000	2 - 2,2	1450/1750	1"	YES	YES	NO	
FO0326B00	E 120/M + INT. FLANGE D.80 B100	BIO D	100	26	230/50	-	750	5,7	1450	1"	YES	YES	NO	



FUEL MANAGEMENT SYSTEMS



DISPENSERS



KITS



PUMPS



METERS



NOZZLES

# E140

## FEATURES

- CONTINUOUS DUTY
- HIGH FLOW RATE
- HEAVY DUTY PUMP
- STURDY DESIGN

The E140 diesel transfer pump is versatile and suitable for different industries including automotive, agriculture, transportation, garages and construction. The E140 volumetric, self-priming vane pump for diesel transfer has a high seal and is reliable in conditions of use at low temperatures. With its solid and resistant body, the E140 is an easy to install diesel transfer pump, suitable for use in diesel dispensers and fixed fuel transfer systems, as well as other industrial applications. The compact cast iron structure makes the E140 electric pump the perfect system for performance and reliability.

### PERFORMANCE

UP TO  
**140 L/MIN**

FLOW RATE

**AC**  
VOLTAGE

POWER



E140



### PACKAGING

CODE	WEIGHT		PACKAGING			N. BOXES / EUROPALLET	
	KG	LBS	MM	INCH	PCS/BOX		
FO0395060	18	40	350X250X300	14X10X12	1	60	72
FO039505A	18	40	350X250X300	14X10X12	1	60	72

The electric motor is exempted from Energy Efficiency Regulation (EU) 2019/1781 in accordance to Article 2(2)(a).



FILTRATION



TANK MONITORING



HOSE REEL



ACCESSORIES



MERCHANDISE



ANY BIODIESEL



AIR



ANTIFREEZE



AdBlue®



BIODIESEL



DIESEL



FOOD



GASOLINE



GREASE



KEROSENE



OIL



WATER



WINDSCREEN

### CHART

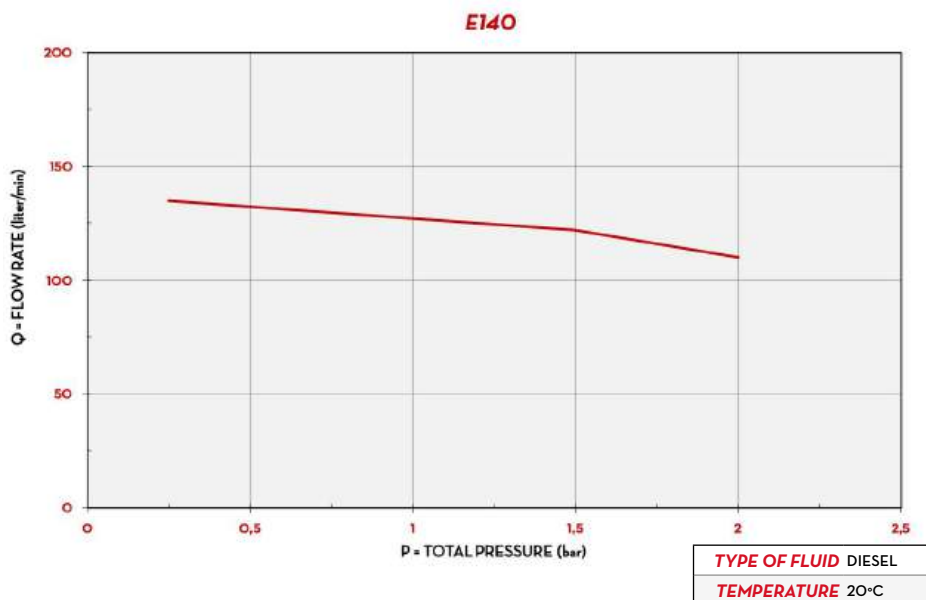

### IN THE BOX

- E140 PUMP
- INSTRUCTION MANUAL

### DETAILS



BYPASS VALVE



VANE ROTOR

### DIMENSIONS

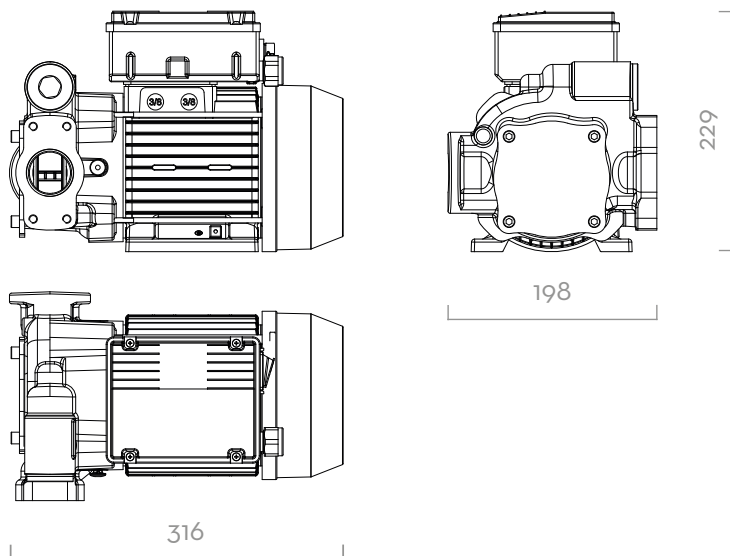

### MATERIALS

- BODY: CAST IRON
- ROTOR: SINTERED STEEL
- VANES: TECHNOPOLYMER
- SEAL: VITON
- SHAFT: STEEL

Dimensions expressed in millimeters

### TECHNICAL DATA

CODE	DESCRIPTION	FLUIDS TYPE	FLOW RATE		VOLTAGE			DUTY CICLE CONTINUOUS	RPM	INLET	OUTLET
			L/MIN	GPM	AC VOLT/HZ	POWER WATT	AMP. MAX.			BSP	
FO0395060	E 140 250/50	D	140	37	250/50	1180	5	S1	1450	1" 1/4	1"
FO039505A	E 140 230/50	D	140	37	230/50	1150	5	S1	1450	1" 1/4	1"



FUEL MANAGEMENT SYSTEMS



DISPENSERS



KITS



PUMPS



METERS



NOZZLES

# E300

## FEATURES

- HIGH-FLOW PUMP
- STURDY STRUCTURE
- HEAVY DUTY APPLICATION
- IP44

The PIUSI E300 is an electric pump with open impeller suitable for all applications in which high-flows are required. Thus, it is the ideal equipment for topping up and transferring diesel from drums. It comes with an incorporated check valve in the suction port to prevent the siphon effect while ensuring automatic re-priming.

### PERFORMANCE

UP TO

**300 L/MIN**

FLOW RATE

**AC**

**CONTINUOUS DUTY**

POWER

**1,7 BAR**

**MAX**

OPERATING PRESSURE

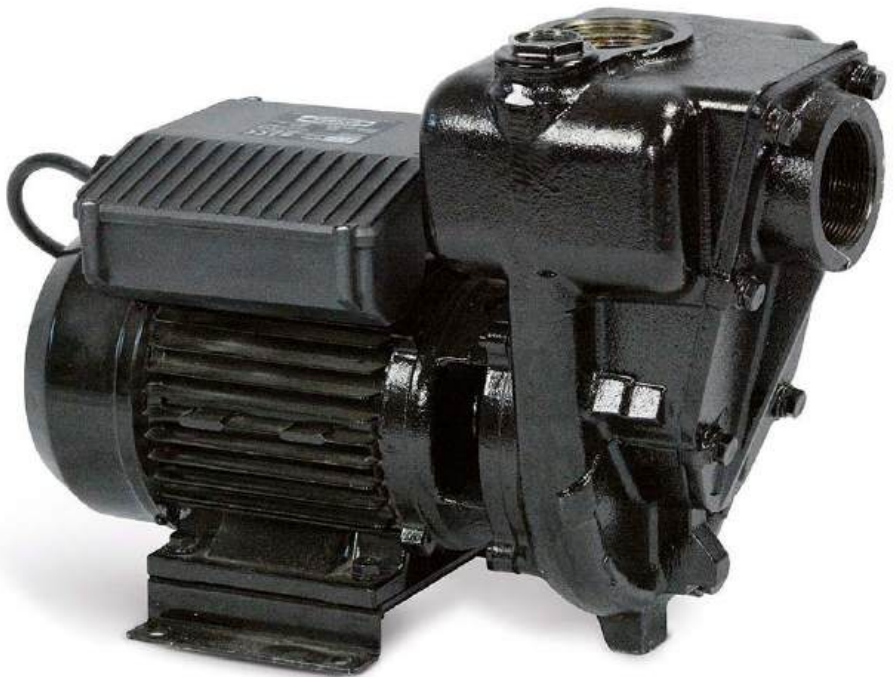

E300

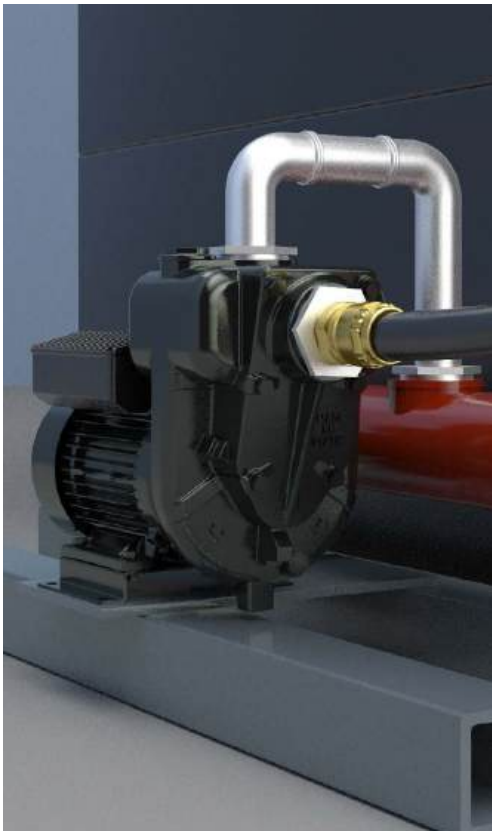

### PACKAGING

CODE	WEIGHT		PACKAGING		
	KG	LBS	MM	INCH	PCS/BOX
FO0321000	27	59	220X420X330	8,7X16,5X13	1



FILTRATION



TANK MONITORING



HOSE REEL



ACCESSORIES



MERCHANDISE



ANY BIODIESEL



AIR



ANTIFREEZE



AdBlue®



BIODIESEL



DIESEL



FOOD



GASOLINE



GREASE



KEROSENE



OIL



WATER



WINDSCREEN

### CHART

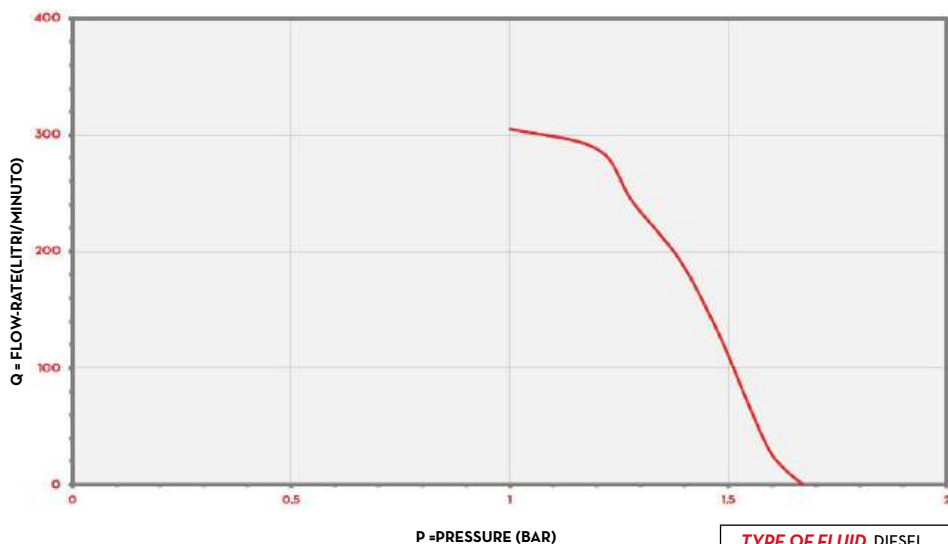

**TYPE OF FLUID** DIESEL  
**TEMPERATURE** 10°C

### DIMENSIONS

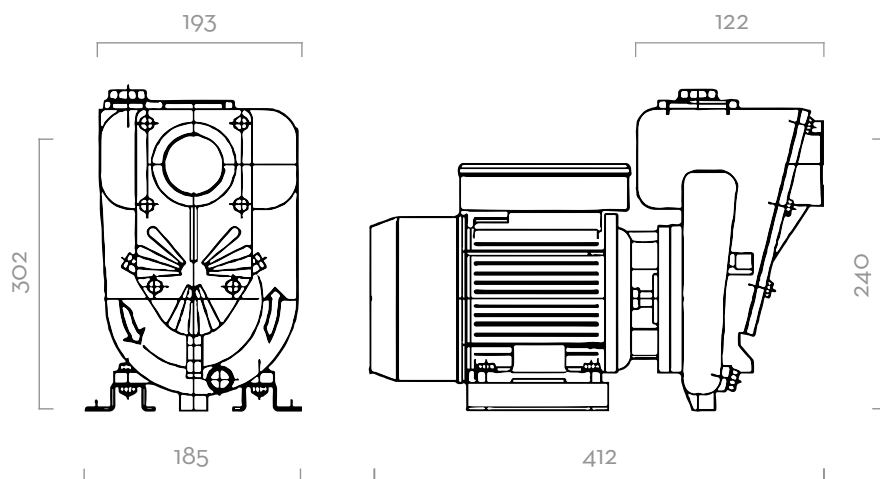

Dimensions expressed in millimeters

### IN THE BOX

- E300 PUMP
- INSTRUCTION MANUAL

### DETAILS



OPEN IMPELLER



2" IN/OUT CONNECTIONS



STEADY SUPPORT

### MATERIALS

- BODY: CAST IRON
- OPEN IMPELLER: CAST IRON
- SEAL: VITON
- SHAFT: STEEL

### TECHNICAL DATA

CODE	DESCRIPTION	FLUIDS TYPE	FLOW RATE		VOLTAGE			RPM	INLET/OUTLET	
			L/MIN	GPM	AC VOLT/HZ	POWER WATT	AMP. MAX.		BSP	
FO0321000	E 300	D	300	80	230/50	1500	7	2580	2"	

# PIUSI 3000 SUPREME



## READY FOR A NEW GENERATION OF REFUELLING PUMPS?

### THE PROBLEMS TYPICALLY ASSOCIATED WITH REFUELLING FROM TRANSPORTABLE TANKS

1. **Security:** is the pump operated by a simple ON button, making it susceptible to unauthorised fuel withdrawals?
2. **Unknown withdrawals:** are you in doubt about who has withdrawn fuel and when?
3. **Overheating:** does the pump overheat when dispensing fuel to vehicles with large fuel tanks?
4. **Failures or malfunctions:** has the pump suffered damage as a result of being connected to the wrong voltage?

### PIUSI 3000 SUPREME IS THE SOLUTION!

1. **Dedicated app** - Secure, controlled and traceable fuel access, only to authorised users in possession of a security PIN
2. **Flow Control Technology** - Automatically reduces the flow rate in the event of overheating. You can also reduce the flow rate manually, from an app, if you want to dispense fuel into small cans
3. **Multi-Battery Technology** - Multi-voltage power supply from 12V to 24V\*, with protection in the event of connection with reversed polarity

\* The Piusi 3000 Supreme does not have the ability to monitor the battery and does not provide any type of protection for it.





### 3 VERSIONS COVERING A FULL RANGE OF NEEDS

	SITE DIMENSIONS		
	1 pump		2 or more pumps
	PIUSI SUPREME	PIUSI SUPREME PRO	B.SMART
Integrated flow control	✓	✓	✓
Login with security PIN	✓	✓	✓
Delivery time-out	✓	✓	✓
Preset function	✓	✓	✓
User Management	Up to 2 users	Up to 10 users	Up to 500 users for each dispenser, unlimited in the system
Dispense history	Last 20	Latest 100, downloadable with CSV file	Filterable report by date
Dispense calendar	-	✓ in the app	✓ in the webapp with filterable report by date
Total dispensed	-	✓ in the last 30 days	✓ Filterable report by date
In-app reminder/To do list	-	✓	-
Level indicator management	-	-	✓ with the TANK WATCHDOG add-on
Consumption management of vehicles and users	-	-	✓ with the FUEL ECONOMY add-on
Geolocation of dispenses	-	-	✓ with the MAPLY add-on

It is possible to upgrade to the higher version even after purchasing the pump

### SOFTWARE UPGRADE (ONE TIME FEE)



ADD-ON	
CODE	DESCRIPTION
FOO250A20	PIUSI SUPREME STANDARD-PRO ADD-ON
FOO250A00	PIUSI SUPREME - B.SMART ADD-ON



FUEL MANAGEMENT SYSTEMS



DISPENSERS



KITS



PUMPS



METERS



NOZZLES

# PIUSI 3000 SUPREME

## FEATURES

- VOLTAGE FROM 12 TO 24V\*
- BLUETOOTH CONNECTION
- TOTAL CONTROL VIA APP
- VIBRATION RESISTANCE
- LOW NOISE
- COMPATIBLE WITH DIESEL UP TO B20 - HVO/XTL
- MAX. PRESSURE 1,5 BAR
- IP55

The **PIUSI 3000 SUPREME** is a highly innovative device designed to offer full pump control and management from a smartphone app, thus helping users fill up with diesel from mobile tanks quickly and safely.

The PIUSI 3000 SUPREME combines new digital technologies with PIUSI's long and proven track-record in the design of fluid management systems such as pumps and flow meters. This new pump is designed to dispense diesel, measure the volume dispensed, manage operator access and solve the problems typically faced by users of transportable tanks.

## PERFORMANCE

UP TO <b>50 L/MIN</b>	FROM <b>12V TO 24V*</b>
FLOW RATE	VOLTAGE
CONTINUOUS DUTY	<b>±0,5%</b>
DUTY CYCLE	ACCURACY

\* The Piusi 3000 Supreme does not have the ability to monitor the battery and does not provide any type of protection for it.



PIUSI 3000 SUPREME



## PACKAGING

CODE	WEIGHT		PACKAGING		
	KG	LBS	MM	INCH	PCS/BOX
FOO250H00	5,4	11,9	270X190X180	-	1
FOO250V00	5,4	11,9	270X190X180	-	1
FOO250D00	7,4	16,3	300X300X180	-	1
FOO250K00	10	22	490X390X310	-	1
FOO250D10	11,5	25,3	490X390X310	-	1





FILTRATION



TANK MONITORING



HOSE REEL



ACCESSORIES



MERCHANDISE

# PIUSI

INDEX



ANY BIODIESEL



AIR



ANTIFREEZE



AdBlue®



BIODIESEL



DIESEL



FOOD



GASOLINE



GREASE



KEROSENE



OIL



WATER



WINDSCREEN



BASE BRACKET KIT



2" DIRECT MOUNT KIT

### DIMENSIONS

#### BASE BRACKET KIT

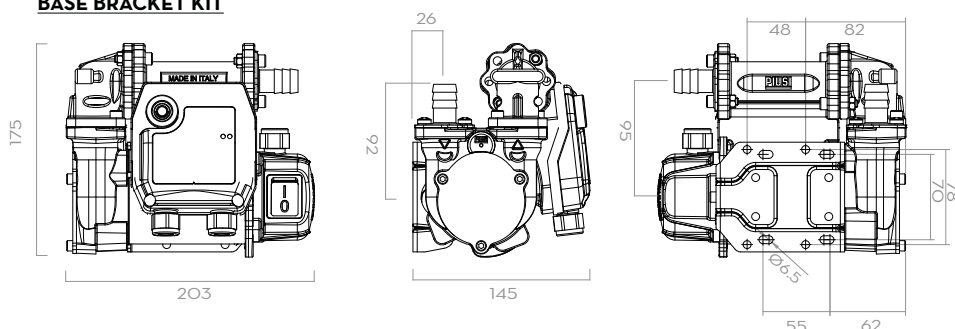

#### 2" DIRECT MOUNT KIT

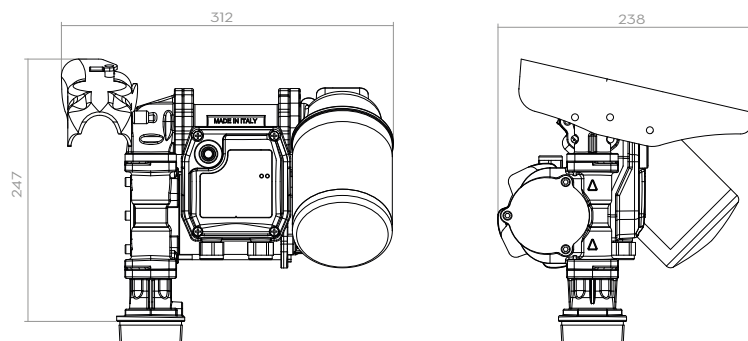

Dimensions expressed in millimeters

### IN THE BOX

- PUMPS
- SUCTION FILTER (BASE BRACKET KIT)
- DELIVERY HOSE (BASE BRACKET KIT & 2" DIRECT MOUNT)
- AUTOMATIC NOZZLE A60
- ELECTRIC CABLE 4M
- OIL & FUEL FILTER (2" DIRECT MOUNT)
- 2" SUCTION CONNECTION (2" DIRECT MOUNT KIT)
- BASE BRACKET (BASE BRACKET KIT)
- NOZZLE HOLDER (2" DIRECT MOUNT KIT)
- ACCESS KEY (IPZ)
- INSTRUCTION MANUAL

### DETAILS



BENDING PROTECTION



ELECTRIC CABLE

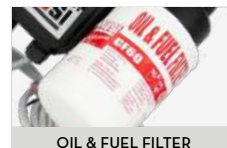

OIL & FUEL FILTER



AUTOMATIC NOZZLE A60

### COMPONENTS

- BODY: CAST IRON
- ROTOR: SINTERED STEEL
- VANES: ACETAL RESIN
- SEAL: NBR
- SHAFT: STEEL

### ACCESSORIES

- AUTOMATIC NOZZLE A60 + HOOK  
COD. F00603S00 (2" DIRECT MOUNT KIT & BASE BRACKET KIT)
- DIESEL HOSE 4M (COD. F24103000)

### TECHNICAL DATA

CODE	DESCRIPTION	FLUIDS TYPE	FLOW RATE		VOLTAGE			RPM	DUTY CYCLE CONTINUOUS	FUSES CAPACITY AMPERE	HOSE		SPIN ON FILTER	NOZZLE
			L/MIN	GPM	DC VOLT	POWER WATT	AMP. MAX.				LENG.	Ø		
F00250H00	PIUSI 3000 SUPREME PUMP ONLY B.O.	D	50	13	FROM 12 TO 24	200W	16A/8A	2700	YES	25A	-	-	-	-
F00250V00	PIUSI 3000 SUPREME PUMP ONLY B.V.	D	50	13	FROM 12 TO 24	200W	16A/8A	2700	YES	25A	-	-	-	-
F00250D00	PIUSI 3000 SUPREME PUMP ONLY DRUM	D	50	13	FROM 12 TO 24	200W	16A/8A	2700	YES	25A	-	-	YES	-
F00250K00	PIUSI 3000 SUPREME BASE BRACKET KIT	D	50	13	FROM 12 TO 24	200W	16A/8A	2700	YES	25A	4MT	3/4"	-	A60
F00250D10	PIUSI 3000 SUPREME 2" DIRECT MOUNT KIT	D	50	13	FROM 12 TO 24	200W	16A/8A	2700	YES	25A	4MT	3/4"	YES	A60



FUEL MANAGEMENT SYSTEMS



DISPENSERS



KITS



PUMPS



METERS



NOZZLES

# BP3000

## FEATURES

- VERSATILE
- ON BOARD APPLICATION
- EMC COMPATIBILITY
- VIBRATION RESISTANT
- IP55

The PIUSI BP3000 is a long-lasting, self-priming vane pump. Powerful, versatile and compact, it is equipped with a built-in by-pass valve. Available in both 12V and 24V versions, it represents the core of the PIUSI range of pumps for on-board applications, particularly in the off-road and earthmoving machinery industry.



BP3000 INLINE



BP3000



BP3000 BIO



### PERFORMANCE

UP TO <b>50 L/MIN</b>	<b>DC</b> VOLTAGE
FLOW RATE	POWER
<b>30 MIN</b>	UP TO <b>4MT</b>
DUTY CICLE	SELF-PRIMING

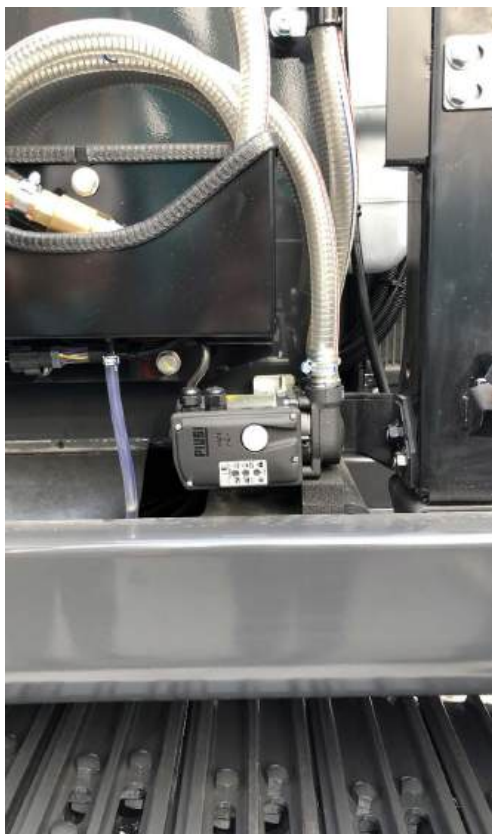

### PACKAGING

CODE	WEIGHT		PACKAGING		
	KG	LBS	MM	INCH	PCS/BOX
FO0342000	3,5	7,9	200X120X140	7,9X4,7X5,5	1
FO0347000	3,5	7,9	200X120X140	7,9X4,7X5,5	1
FO0357000	3,5	7,9	200X120X140	7,9X4,7X5,5	1
FO0357500	3,5	7,9	200X120X140	7,9X4,7X5,5	1
FO0358000	3,5	7,9	200X120X140	7,9X4,7X5,5	1
FO0358500	3,5	7,9	200X120X140	7,9X4,7X5,5	1
FO0342B00	3,5	7,9	200X120X140	7,9X4,7X5,5	1



FILTRATION



TANK MONITORING



HOSE REEL



ACCESSORIES



MERCHANDISE

# PIUSI

INDEX



ANY BIODIESEL



AIR



ANTIFREEZE



AdBlue®



BIODIESEL



DIESEL



FOOD



GASOLINE



GREASE



KEROSENE



OIL



WATER



WINDSCREEN

## CHART

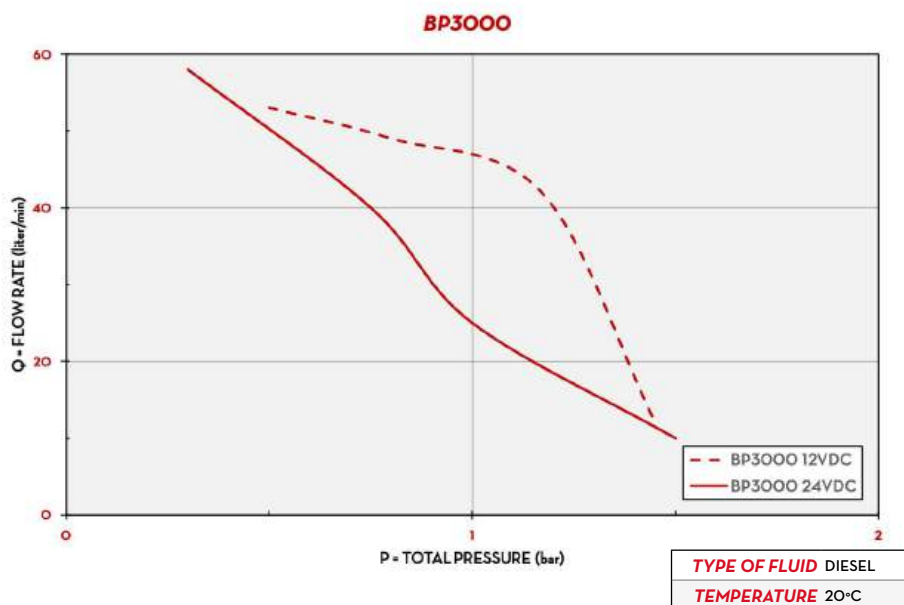

## DIMENSIONS

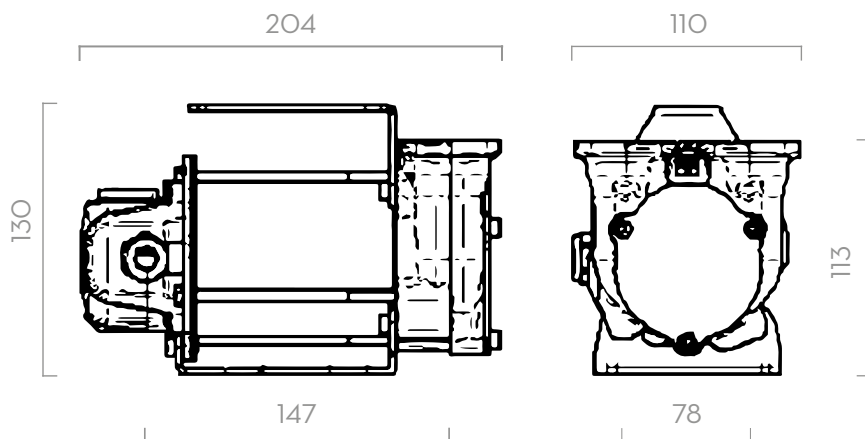

Dimensions expressed in millimeters

## IN THE BOX

- BP3000 PUMP
- INSTRUCTION MANUAL

## DETAILS



VANE ROTOR



IN-LINE VERSION AVAILABLE



CONNECTION KIT

## MATERIALS

- BODY: CAST IRON
- ROTOR: SINTERED STEEL
- VANES: ACETAL RESIN
- SEAL: NBR
- SHAFT: STEEL



PUMP

- > MAX 6M (20FT),
- > SUCTION HOSE Ø 1" MIN,
- > MAX SUCTION HEIGHT:
  - 2M (7FT) W/O NON RETURN VALVE
  - 4M (14FT) W NON RETURN VALVE



TANK

## TECHNICAL DATA

CODE	DESCRIPTION	FLUIDS TYPE	FLOW RATE		VOLTAGE			DUTY CYCLE	RPM	THREADED PORTS BSP	MAX WORKING PRESSURE BAR
			L/MIN	GPM	DC VOLT	POWER WATT	AMP. MAX.				
FO0342000	BP3000 12V	D	50	13	12	300	24	30	2900	-	1,5
FO0347000	BP3000 24V	D	50 / 30	13 / 6	24/12	310 / 80	13 / 6,5	30	2900 / 1500	-	1,5
FO0357000	BP3000 12V INLINE	D	50	13	12	300	24	30	2900	-	1,5
FO0357500	BP3000 12V INLINE 3/4" BSP	D	50	13	12	300	24	30	2900	3/4"	1,5
FO0358000	BP3000 24V INLINE	D	50 / 30	13 / 6	24/12	310 / 80	13 / 6,5	30	2900 / 1500	-	1,5
FO0358500	BP3000 24V INLINE 3/4" BSP	D	50 / 30	13 / 6	24/12	310 / 80	13 / 6,5	30	2900 / 1500	3/4"	1,5
FO0342B00	BP3000 12V B100	BIO D	50	13	12	300	24	30	2900	-	1,5



FUEL MANAGEMENT SYSTEMS



DISPENSERS



KITS



PUMPS



METERS



NOZZLES

# PANTHER DC

## FEATURES

- STURDY STRUCTURE
- EASY TO INSTALL
- COMPACT DESIGN
- IP55

The PANTHER DC is a rotary, self-priming vane pump suitable for all applications in which important flow rates are required. This equipment is fitted with an incorporated filter (500µ) and by-pass valve. The 24/12 V version can be used with both voltages.

### PERFORMANCE

UP TO

**70 L/MIN**

FLOW RATE

**12/24V**

VOLTAGE

POWER

**30 MIN**

DUTY CYCLE



PANTHER DC



### PACKAGING

CODE	WEIGHT		PACKAGING		
	KG	LBS	MM	INCH	PCS/BOX
FO034000B	7,5	16,5	345X175X255	13,6X6,9X10	1
FO034001C	7,5	16,5	345X175X255	13,6X6,9X10	1
FO034100C	7,5	16,5	345X175X255	13,6X6,9X10	1
FO034101C	7,5	16,5	345X175X255	13,6X6,9X10	1
FO034116C	7,5	16,5	345X175X255	13,6X6,9X10	1



FILTRATION



TANK MONITORING



HOSE REEL



ACCESSORIES



MERCHANDISE

# PIUSI

INDEX

B

ANY BIODIESEL

A

AIR

A

ANTIFREEZE

Ad

AdBlue®

B

BIODIESEL

D

DIESEL

F

FOOD

G

GASOLINE

G

GREASE

K

KEROSENE

O

OIL

W

WATER

W

WINDSCREEN

## CHART

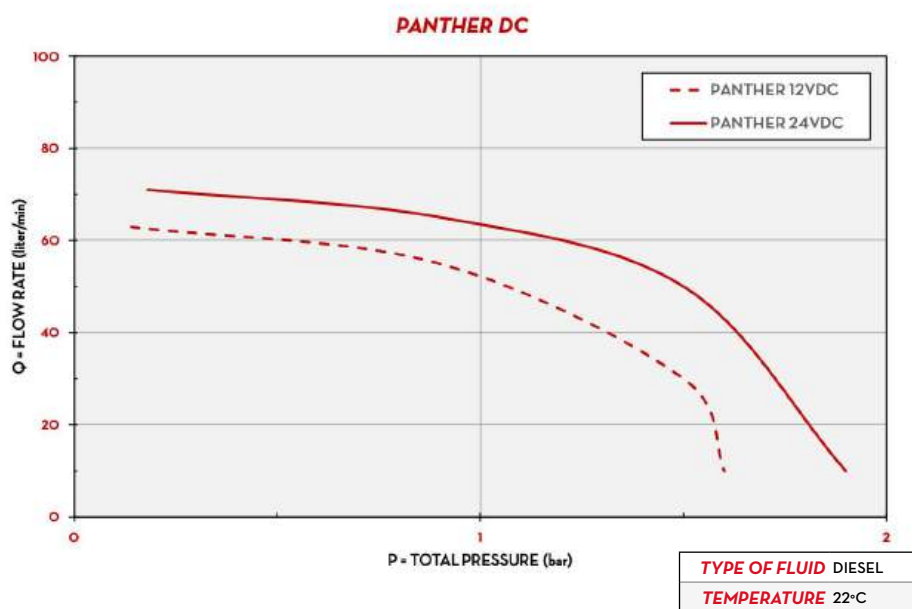

## DIMENSIONS

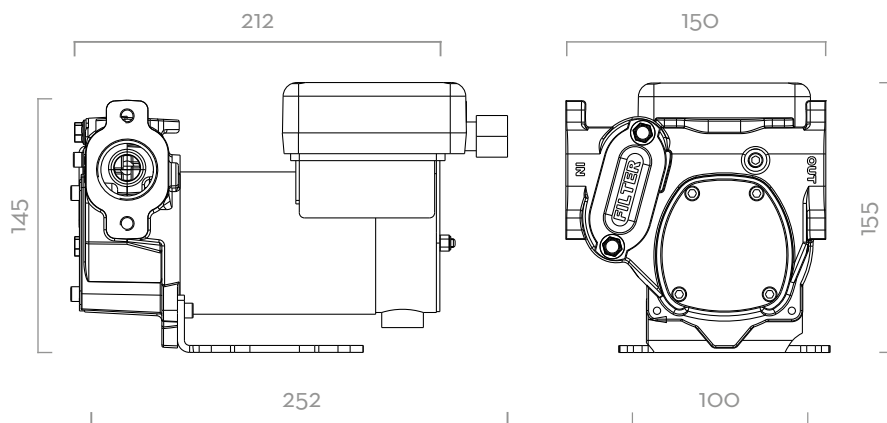

Dimensions expressed in millimeters

## IN THE BOX

- PANTHER DC PUMP
- INSTRUCTION MANUAL

## DETAILS



ON/OFF SWITCH



1" BSP THREADED



INTEGRATED FILTER

## MATERIALS

- BODY: CAST IRON
- ROTOR: SINTERED STEEL
- VANES: ACETAL RESIN
- MOTOR: ALUMINIUM CASING



PUMP

- MAX 6M (20FT),
- SUCTION HOSE Ø 1" MIN,
- MAX SUCTION HEIGHT:
  - 2M (7FT) W/O NON RETURN VALVE
  - 4M (14FT) W NON RETURN VALVE



TANK

## TECHNICAL DATA

CODE	DESCRIPTION	FLUIDS TYPE	FLOW RATE		VOLTAGE			DUTY CICLE	RPM	OUTLET
			L/MIN	GPM	DC VOLT	POWER WATT	AMP. MAX.			
FO034000B	PANTHER DC 12V	D	56	14,8	12	300	35	30	2900	1"
FO034001C	PANTHER DC 12V W/CABLE 2MT W/PLIERS	D	56	14,8	12	300	35	30	2900	1"
FO034100C	PANTHER DC 24/12V	D	70 / 35	18,5 / 9,2	24/12	420 / 150	25 / 16	30	3600 / 1800	1"
FO034101C	PANTHER DC 12/24V W/CABLE 2MT W/CLIPS	D	70 / 35	18,5 / 9,2	24/12	420 / 150	25 / 16	30	3600 / 1800	1"
FO034116C	PANTHER DC 12/24V W/CABLE 4MT W/CLIPS	D	70 / 35	18,5 / 9,2	24/12	420 / 150	25 / 16	30	3600 / 1800	1"



FUEL MANAGEMENT SYSTEMS



DISPENSERS



KITS



PUMPS



METERS



NOZZLES

# BIPUMP

## FEATURES

- STURDY STRUCTURE
- COMPACT DESIGN
- HEAVY DUTY
- HIGH RELIABILITY
- IP55

The PIUSI BIPUMP is a diesel transfer pump, available both in 12 and 24 V versions, designed to meet the needs of those who are looking for a long-lasting quality, high flow rate pump, applicable to different industries. It is easy to install and is suitable for being applied on diesel dispensers and fixed fuel transfer systems, as well as other applications.

### PERFORMANCE

UP TO

**85 L/MIN**

FLOW RATE

**12/24V**

VOLTAGE

POWER

**30 MIN**

DUTY CICLE



BIPUMP



### PACKAGING

CODE	WEIGHT		PACKAGING			N. BOXES / EUROPALLET	
	KG	LBS	MM	INCH	PCS/BOX	✕	
FO0363A0A	12,7	28,1	345X175X255	-	1	60	72
FO0363B0A	12,6	27,9	345X175X255	-	1	60	72
FO036301A	9,9	21,8	345X175X255	-	1	60	72
FO036302A	9,9	21,8	345X175X255	-	1	60	72
FO036303A	9,9	21,8	345X175X255	-	1	60	72
FO036304A	9,9	21,8	345X175X255	-	1	60	72
FO036321A	12,36	27,2	345X175X255	-	1	60	72



FILTRATION



TANK MONITORING



HOSE REEL



ACCESSORIES



MERCHANDISE

# PIUSI

INDEX

B

ANY BIODIESEL

A

AIR

A

ANTIFREEZE

Ad

AdBlue®

B

BIODIESEL

D

DIESEL

F

FOOD

G

GASOLINE

G

GREASE

K

KEROSENE

O

OIL

W

WATER

W

WINDSCREEN

## CHART

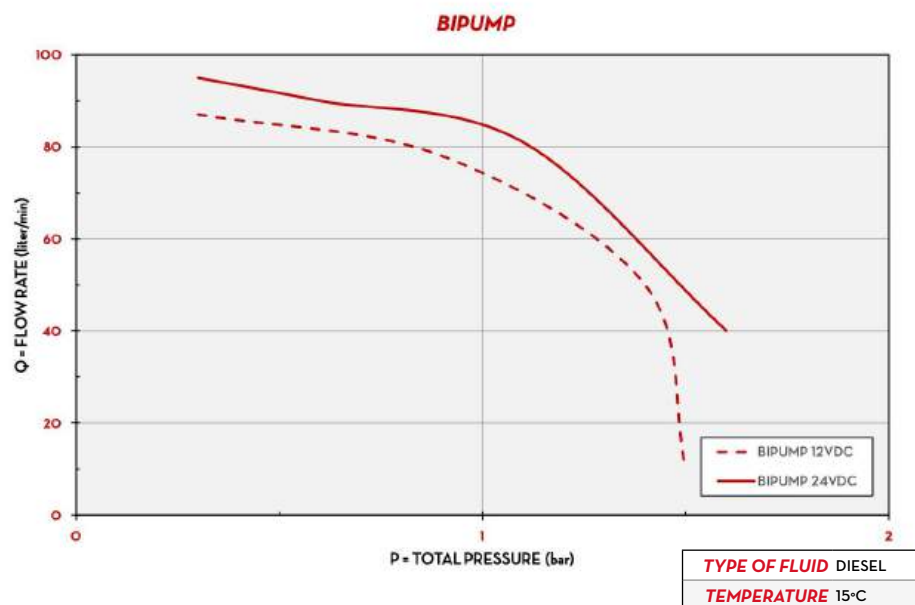

## DIMENSIONS

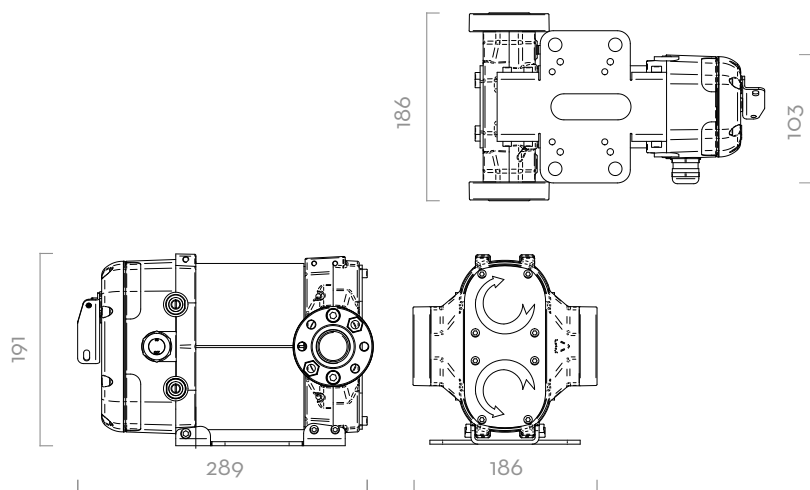

Dimensions expressed in millimeters

## IN THE BOX

- BIPUMP UNIT
- FLANGED CONNECTIONS
- INSTRUCTION MANUAL

## DETAILS



ON/OFF SWITCH



FLANGED CONNECTIONS

## MATERIALS

- BODY: CAST IRON
- ROTOR: SINTERED STEEL
- VANES: ACETAL RESIN
- SEAL: NBR
- SHAFT: STEEL



PUMP

- MAX 6M (20FT),
- SUCTION HOSE Ø 1" MIN,
- MAX SUCTION HEIGHT:
- 2M (7FT) W/O NON RETURN VALVE
- 4M (14FT) W NON RETURN VALVE



TANK

## TECHNICAL DATA

CODE	DESCRIPTION	FLUIDS TYPE	FLOW RATE		VOLTAGE			DUTY CICLE	RPM	OUTLET
			L/MIN	GPM	DC VOLT	POWER WATT	AMP. MAX.			
FOO363AOA	BIPUMP 12V WITH ON/OFF SWITCH	D	85	22,4	12	500	42	30	2000	1"
FOO363BOA	BIPUMP 24V WITH ON/OFF SWITCH	D	85	22,4	24	500	21	30	2000	1"
FOO363O1A	BIPUMP 12V WITH CABLE 2M	D	85	22,4	12	500	42	30	2000	1"
FOO363O2A	BIPUMP 12V WITH CABLE 4M	D	85	22,4	12	500	42	30	2000	1"
FOO363O3A	BIPUMP 24V WITH CABLE 2M	D	85	22,4	24	500	21	30	2000	1"
FOO363O4A	BIPUMP 24V WITH CABLE 4M	D	85	22,4	24	500	21	30	2000	1"
FOO36321A	BIPUMP 12/24 WITHOUT ON/OFF SWITCH	D	85	22,4	12/24	500/500	42/21	30/30	2000	1"



FUEL MANAGEMENT SYSTEMS



DISPENSERS



KITS



PUMPS



METERS



NOZZLES

# PIUSI HAND PUMP

## FEATURES

- OPTIMIZED SUCTION CAPACITY
- STURDY CONNECTOR
- HEAVY DUTY LEVER
- FLUENT REVOLUTION
- HIGH EFFICIENCY
- ADJUSTABLE SUCTION PIPE

The PIUSI HAND PUMP is a rotary vane pump suitable for transferring low viscosity oils and diesel. Entirely designed, manufactured and certified in Italy, this sturdy pump guarantees a professional performance and easy transfer.

## PERFORMANCE

UP TO

**38L**

PER 100 REVOLUTIONS

FLOW RATE

**3MT**

LENGTH

DELIVERY HOSE



PIUSI HAND PUMP WITH HOSE AND STAINLESS STEEL SPOUT



## PACKAGING

CODE	WEIGHT		PACKAGING			N. BOXES / EUROPALLET	
	KG	LBS	MM	INCH	PCS/BOX		
FOO33250A	2,1	4,6	350X170X140	-	1	50	100
FOO33252A	3,2	7	300X300X180	-	1	50	100





FILTRATION



TANK MONITORING



HOSE REEL



ACCESSORIES



MERCHANDISE

# PIUSI

INDEX

B

ANY BIODIESEL

A

AIR

A

ANTIFREEZE

Ad

AdBlue®

B

BIODIESEL

D

DIESEL

F

FOOD

G

GASOLINE

G

GREASE

K

KEROSENE

O

OIL

W

WATER

W

WINDSCREEN

## CHART

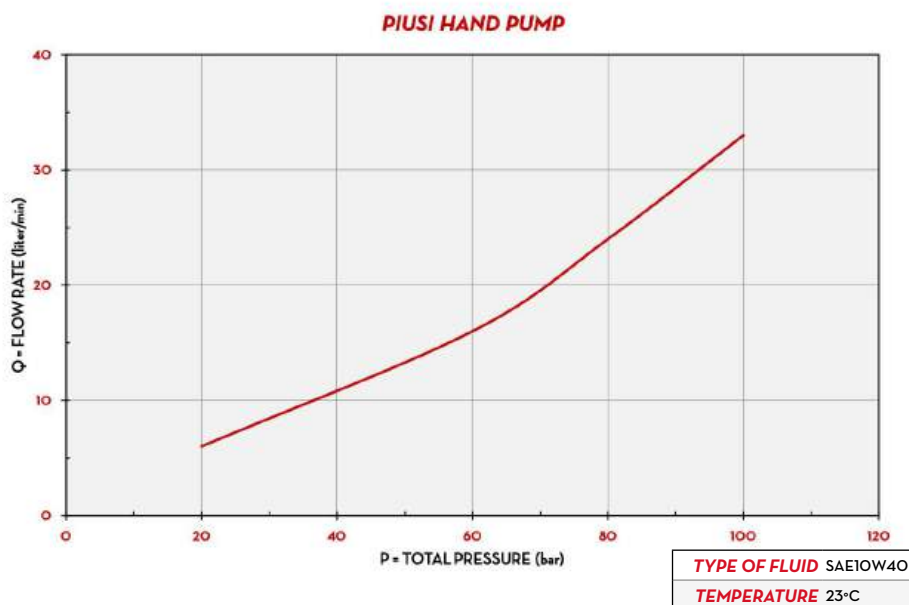

## DIMENSIONS

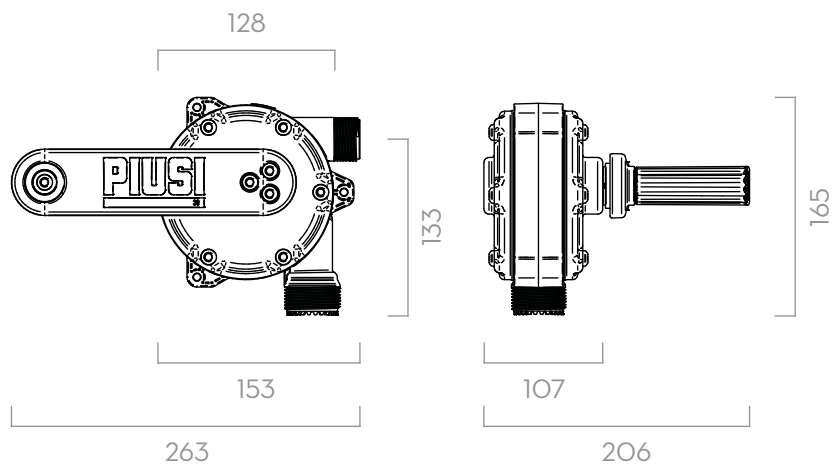

Dimensions expressed in millimeters

## IN THE BOX

- PIUSI HAND PUMP
- SPOUT
- SUCTION PIPE
- DRUM CONNECTOR
- INSTRUCTION MANUAL

## DETAILS



2" BSP DRUM CONNECTOR



SUCTION PIPE



NON-SLIP HANDLE



STAINLESS STEEL SPOUT

## MATERIALS

- BODY: STAINLESS STEEL, TECHNOPYLIMER
- ROTOR: TECHNOPYLIMER
- VANES: TECHNOPYLIMER

## TECHNICAL DATA

CODE	DESCRIPTION	FLUIDS TYPE	CAPACITY PER 100 REVOLUTIONS		DRUM CONNECTOR	SUCTION TUBE	"S" SPOUT AND HOSE TAIL	DELIVERY HOSE LENGTH
			L	USG				
FO033250A	PIUSI HAND PUMP 2" BSP	D O	38	10	2" BSP	YES	YES	-
FO033252A	KIT PIUSI HAND PUMP 2" BSP WITH HOSE	D O	38	10	2" BSP	YES	-	3M



FUEL MANAGEMENT SYSTEMS



DISPENSERS



KITS



PUMPS



METERS



NOZZLES

# HAND PUMPS

## FEATURES

- STURDY CONNECTOR
- SUCTION PIPE INCLUDED
- MULTI-PURPOSE PUMPS

Besides the top-quality Hand Pump, PIUSI offers a range of HAND PUMPS with different characteristics - piston or rotary - and fittings to transfer fluids from drums.

### PERFORMANCE

UP TO

**90L**

PER 100 REV

FLOW RATE

UP TO

**1,1 MT**

LENGTH

SUCTION HOSE



PM GPI PISTON

### PACKAGING

CODE	WEIGHT		PACKAGING			N. BOXES / EUROPALLET	
	KG	LBS	MM	INCH	PCS/BOX	✕	
FO031600B	5,3	11,7	465X395X240	-	1	30	40
FO034900B	3,0	6,6	600X110X65	-	1	160	240
FO035100B	3,0	6,6	300X150X105	-	1	160	200



FILTRATION



TANK MONITORING



HOSE REEL



ACCESSORIES



MERCHANDISE

# PIUSI

INDEX

IS

ANY BIODIESEL

A

AIR

A

ANTIFREEZE

Ad

AdBlue®

B

BIODIESEL

D

DIESEL

F

FOOD

G

GASOLINE

G

GREASE

K

KEROSENE

O

OIL

W

WATER

W

WINDSCREEN



PISTON HAND PUMP



ALUMINIUM ROTATIVE

### IN THE BOX

- ROTARY/PISTON PUMP
- SUCTION TUBE
- CONNECTOR/ADAPTOR
- SPOUT/DELIVERY HOSE
- INSTRUCTION MANUAL

### DETAILS



NON-SLIP HANDLE



PISTON HAND PUMP

### MATERIALS

- BODY: IRON/STAINLESS STEEL/ALUMINIUM



## TECHNICAL DATA





CODE	DESCRIPTION	FLUIDS TYPE	CAPACITY	INLET / OUTLET	SUCTION HOSE LENGTH MM
			L / 100REV		
FOO3160OB	PM GPI PISTON	O D G K	90	1-3/4" NPT	1100
FOO3490OB	PISTON HAND PUMP 25 L/M	D O	25	END HOSE Ø 20	880
FOO3510OB	PISTON HAND PUMP 35 L/M	D O	35	END HOSE Ø 20	880







# PUMPS ACCESSORIES



## POMPE ATEX AC/DC

EX50	CODE	DESCRIPTION		
	F1862600A	(EX)CABLE+CABLEGLAND ECEX EX50 12V	 	<b>F1815600B</b> <b>F1862600A</b>
	F1815600B	(EX) ADAPTER FOR CONDUIT EX50		
	F1862400C	(EX) PRESSACAVO EXxdI/2NPT IECEx		

EX100	CODE	DESCRIPTION			
	F21770000	BUNG ADAPTER 2" BSP COMPLETE	  	<b>F22436010</b> <b>F22053000</b> <b>F21770000</b>	
	F22436010	ANTISIPHONE KIT FOR EX100/EX140/E140 BSP			
	F22053000	MOTOR SUPPORT FEET EX80/100/140			

EX140	CODE	DESCRIPTION			
	F21770000	BUNG ADAPTER 2" BSP COMPLETE	  	<b>F22436010</b> <b>F22053000</b> <b>F21770000</b>	
	F22436010	ANTISIPHONE KIT FOR EX100/EX140/E140 BSP			
	F22053000	MOTOR SUPPORT FEET EX80/100/140			

## HAND PUMP

PIUSI HAND PUMP	CODE	DESCRIPTION		
	F15236000	ADATTATORE M/F 2IN - 56X4 ADBLUE	 	<b>R1512800A</b> <b>F15236000</b>
	R1512800A	ADAPTER M/F 2" - S7OX6 ADBLUE		



## POMPE AC/DC

E80 / E120	CODICE	DESCRIZIONE
	F1392000A	KIT ANTI-SYPHON FOR P56/72 E80/120

E140	CODICE	DESCRIZIONE
	F22436010	ANTISIPHON KIT FOR EX100/EX140/E140 BSP



  
**F22436010**

BP3000	CODICE	DESCRIZIONE
	F1701800A	KIT TERMINAL BOX+4M CABLE W\CLAMP 12-24V
	F1728900A	KIT TERMINAL BOX+2M CABLE W\CLAMP 12-24V
	F1729000A	KIT TERMINAL BOX+6M CABLE W\CLAMP 12-24V
	R1601100B	ELECTRICAL BOX WITH SWITCH BP3000



  
**R1601100B**  
  
**F1701800A**  
**F1729000A**  
**F1728900A**

### SPECIFIC CONNECTIONS FOR BP3000



	F1617300A	LP 3/4 90° HOSE TAIL KIT (1 PCS.)		F16178000	LP 90° FLANGED ELBOW-NEW
	F1726200A	HOSE TAIL 90° 1"		F16770000	KIT N.1 ELBOW 90° WITHOUT FLANGE

	F16172000	LP 3/4 STRAIGHT HOSE TAIL KIT (2 PCS.)-N		F16799000	FLANGED ADAPTER BP3000-VANTAGE 1" G-F
	F17124000	STRAIGHT HOSE TAIL 1" BP3000		F17313000	FLANGED ADAPTER BP3000 \ VANTAGE 1ING -
				F17314000	FLANGED ADAPTER BP3000\ VANTAGE 3/4ING -F

PANTHER DC	CODICE	DESCRIZIONE
	F1001100A	CABLE 2X6X2 MT EYELET TERMINAL 12V
	F1004000A	CABLE 2X6X2 MT EYELET TERMINAL 24V
	F1004100A	CABLE 2X6X4 MT EYELET TERMINAL 12V
	F1003900A	CABLE 2X6X4 MT EYELET TERMINAL 24V
	R13242000	KIT MANIGLIA PANTHER DC

  
**R10011000**  
**R10040000**  
**R10041000**  
**R10039000**  
  
**R13242000**

BIPUMP	CODICE	DESCRIZIONE
	F1420000B	KIT MANIGLIA BIPUMP
	F1433400A	CABLE 2X6X2MT BIPUMP
	F1433500A	CABLE 2X6X4MT BIPUMP

  
**R14334000**  
**R14335000**  
  
**F1420000B**

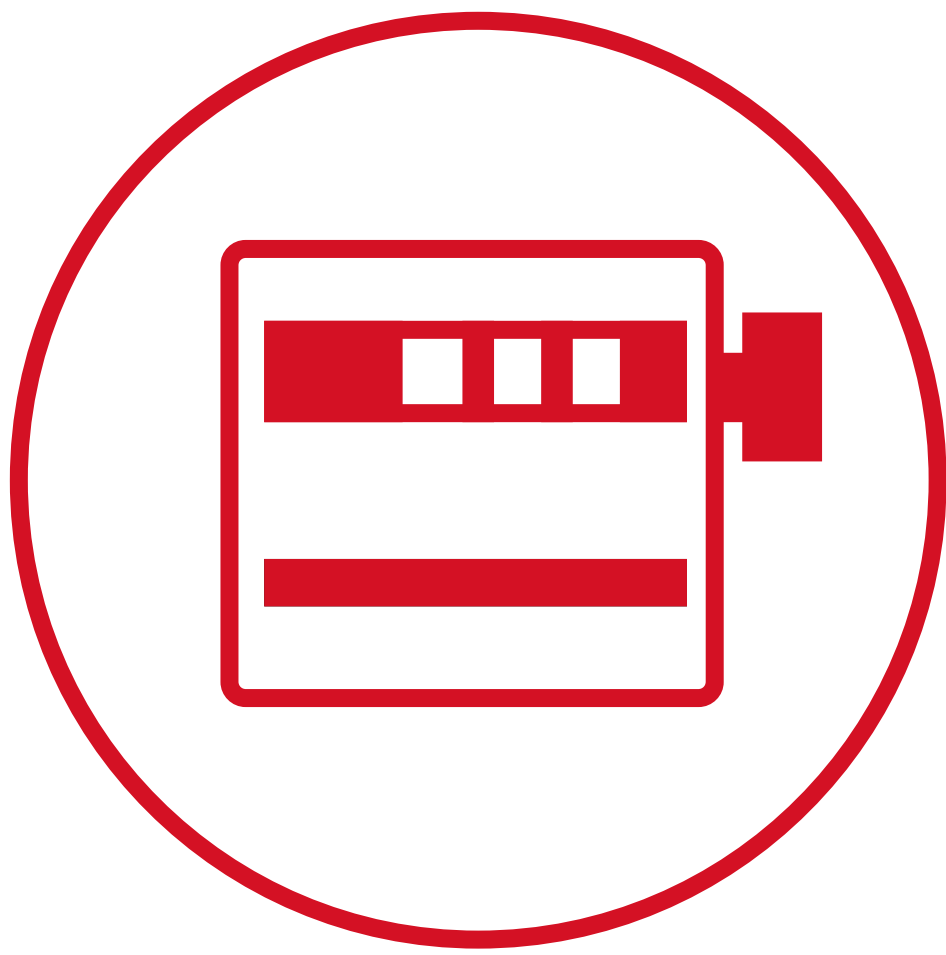

**METERS**





FUEL MANAGEMENT SYSTEMS



DISPENSERS



KITS



PUMPS



METERS



NOZZLES

# K24 ATEX



## FEATURES

- BURSTING PRESSURE 100 BAR
- LCD DISPLAY
- FLOW RATE INDICATION
- EASY TO CALIBRATE
- UL VERSION AVAILABLE

The PIUSI K24 ATEX, specifically designed to be compliant with ATEX/IECEX requirements, is manufactured using high-quality materials compatible with gasoline, kerosene and diesel to be used in potentially explosive areas. This turbine flow meter is equipped with a 6-digit totalizer and partial reset.

### PERFORMANCE

**7-120**

L/MIN

FLOW RATE

**20 BAR**

MAX

OPERATING PRESSURE

**± 1%**

ACCURACY

**0,3%**

REPEATABILITY



K24 ATEX / IECEX



OUR PRODUCT COMPLIES WITH THE FOLLOWING MARKING ATEX/IECEX

II	2	G	Ex	ia	IIB	T4	Gb
GROUP	CATEGORY	TYPE OF EXPLOSIVE ATMOSPHERE	PERMANENT PREFIX	PROTECTION METHOD	GAS GLASS	TEMPERATURE CLASS	EQUIPMENT PROTECTION LEVEL

### PACKAGING

CODE	WEIGHT		PACKAGING		
	KG	LBS	MM	INCH	PCS/BOX
<b>K24 A ATEX/IECEX METER</b>					
FOO408X00	0,65	1,4	115X16OX135	4,5X6,3X5,3	1
<b>K24 A ATEX/IECEX PULSER</b>					
FOO408Y00	0,65	1,4	115X16OX135	4,5X6,3X5,3	1





FILTRATION



TANK MONITORING



HOSE REEL



ACCESSORIES



MERCHANDISE

# PIUSI

INDEX

B

ANY BIODIESEL

A

AIR

A

ANTIFREEZE

Ad

AdBlue®

B

BIODIESEL

D

DIESEL

F

FOOD

G

GASOLINE

G

GREASE

K

KEROSENE

O

OIL

W

WATER

W

WINDSCREEN

## CHART

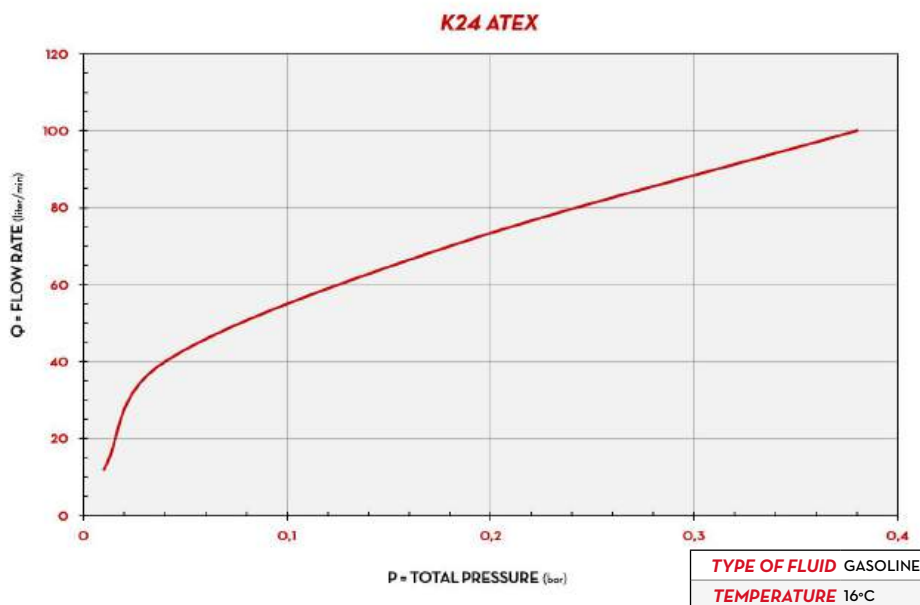

## DIMENSIONS

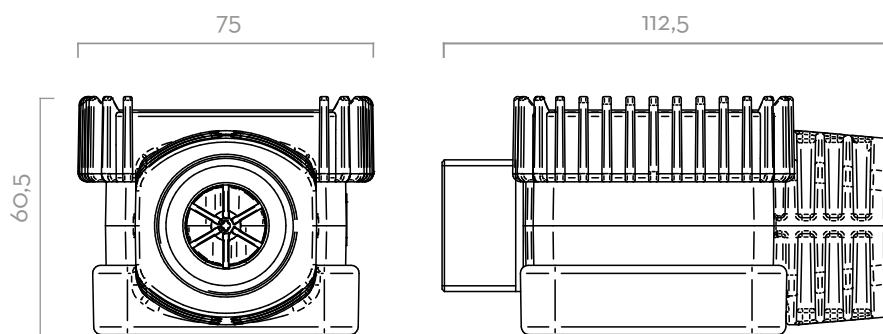

Dimensions expressed in millimeters

## IN THE BOX

- K24 ATEX METER
- INSTRUCTION MANUAL

## DETAILS



## MATERIALS

- BODY: ALUMINIUM
- GEARS: TECHNOPOLYMER

## TECHNICAL DATA

CODE	DESCRIPTION	FLUIDS TYPE	FLOW RATE		PRESSURE		SPECIAL BATTERY INCLUDED N° 1.3V LITHIUM	FLANGE	INLET / OUTLET
			L/MIN	GPM	BAR	PSI			
<b>K24 A ATEX/IECEX METER</b>									
FOO408X00	K24 A M/F 1" BSP ATEX/IECEX	D G K	7 - 120	2 - 32	20	300	YES	NO	M 1" BSP - F 1" BSP
<b>K24 A ATEX/IECEX PULSER</b>									
FOO408Y00	K24 A PULSER M/F 1" BSP ATEX/IECEX (92 PULSE/L)	D G K	7 - 120	2 - 32	20	300	NO	NO	M 1" BSP - F 1" BSP

FLUIDS PERMITTED: DIESEL, KEROSENE, PETROL, PETROL ALCOHOL MIXED MAX 20%, AVGAS 100/100LL (PUMP ONLY), JET A/A1 (PUMP ONLY) - ASPEN 2/4. UL CLASSIFIED VERSION AVAILABLE



FUEL MANAGEMENT SYSTEMS



DISPENSERS



KITS



PUMPS



METERS



NOZZLES

# K33 ATEX



## FEATURES

- BURSTING PRESSURE 28 BAR
- 3 DIGIT DISPLAY
- EASY TO CALIBRATE
- 4 FLOW DIRECTIONS

The PIUSI K33 ATEX is an oval gear mechanical meter engineered for an accurate measuring of the quantity of fluid dispensed that meets the ATEX/IECEX requirements related to the use in potentially explosive atmospheres. Reliable and easy to install, it can be calibrated on site and simply fitted with both rigid or flexible pipes or can be put directly on pumps and tanks.

### PERFORMANCE

**20-120**

L/MIN

FLOW RATE

**3,5 BAR**

MAX

OPERATING PRESSURE

**± 1%**

ACCURACY

**0,3%**

REPEATABILITY



K33 - ATEX



OUR PRODUCTS COMPLIES WITH THE FOLLOWING MARKING ATEX

<b>II</b>	<b>2</b>	<b>G</b>	<b>c</b>	<b>IIB</b>	<b>T6</b>
GROUP	CATEGORY	TYPE OF EXPLOSIVE ATMOSPHERE	PROTECTION METHOD	GAS GLASS	TEMPERATURE CLASS

### PACKAGING

CODE	WEIGHT		PACKAGING			N. BOXES / EUROPALET	
	KG	LBS	MM	INCH	PCS/BOX		
FO057000A	2,02	4,44	180X180X170	-	1	192	240
FO057001A	2,02	4,44	180X180X170	-	1	192	240
FO057002A	2,02	4,44	180X180X170	-	1	192	240
FO057003A	2,02	4,44	180X180X170	-	1	192	240



FILTRATION



TANK MONITORING



HOSE REEL



ACCESSORIES



MERCHANDISE

# PIUSI

INDEX

B

ANY BIODIESEL

A

AIR

A

ANTIFREEZE

Ad

AdBlue®

B

BIODIESEL

D

DIESEL

F

FOOD

G

GASOLINE

G

GREASE

K

KEROSENE

O

OIL

W

WATER

W

WINDSCREEN

## CHART



## DIMENSIONS

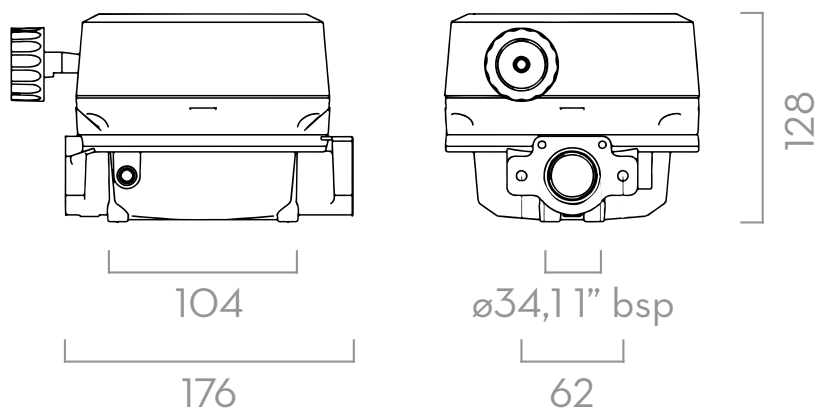

Dimensions expressed in millimeters

## IN THE BOX

- K33 ATEX METER
- INSTRUCTION MANUAL

## DETAILS



NUTATING DISK SYSTEM



4 FLOW DIRECTIONS



ATEX APPROVED



SAFETY BONDING

## MATERIALS

- BODY: ALUMINIUM
- NUTATING DISK CHAMBER: TECHNOPYLIMER

## TECHNICAL DATA

CODE	DESCRIPTION	FLUIDS TYPE	FLOW DIRECTION	FLOW RATE		PRESSURE		INLET / OUTLET
				L/MIN	GPM	BAR	PSI	
FO057000A	K33 - ATEX VER. A	D G K	←	20 - 120	5 - 32	3,5	50	1" BSP
FO057001A	K33 - ATEX VER. B	D G K	↑	20 - 120	5 - 32	3,5	50	1" BSP
FO057002A	K33 - ATEX VER. C	D G K	↓	20 - 120	5 - 32	3,5	50	1" BSP
FO057003A	K33 - ATEX VER. D	D G K	→	20 - 120	5 - 32	3,5	50	1" BSP

FLUIDS PERMITTED: DIESEL, KEROSENE, PETROL, PETROL ALCOHOL MIXED MAX 20%, AVGAS 100/100LL (PUMP ONLY), JET A/A1 (PUMP ONLY) - ASPEN 2/4. UL CLASSIFIED VERSION AVAILABLE



FUEL MANAGEMENT SYSTEMS



DISPENSERS



KITS



PUMPS



METERS



NOZZLES

# K150 ATEX



## FEATURES

- HEAVY DUTY CONDITIONS
- HIGH FLOW RATE
- BURSTING PRESSURE 28 BAR
- EASY READING
- 4 FLOW DIRECTIONS

K150 ATEX is expressly engineered to meet the market requirements of a meter suitable for flow rates superior than 120 l/min and that can be used both for fluids such as diesel and biodiesel, as well as in potentially explosives atmosphere; with gasoline for example. K150 is easy to calibrate and ready to use; its aluminium cover and sturdy body make this meter suitable for a wide arrange of application while guaranteeing the same precision and quality that have always featured PIUSI equipment. The mechanical display allows to read quickly the quantity dispensed. It can be installed everywhere thanks to the (optional) 1,5" flange kit. K150 is certified CE, ATEX/UL and tested in PIUSI laboratories for over 4 milion litres to guarantee the maximum reliability.

### PERFORMANCE

UP TO <b>25-150</b> L/MIN FLOW RATE	<b>3,5 BAR</b> MAX OPERATING PRESSURE
<b>± 1%</b> ACCURACY	<b>0,3%</b> REPEATABILITY



K150

OUR PRODUCTS COMPLIES WITH THE FOLLOWING MARKING ATEX

<b>II</b> GROUP	<b>2</b> CATEGORY	<b>G</b> TYPE OF EXPLOSIVE ATMOSPHERE	<b>c</b> PROTECTION METHOD	<b>IIB</b> GAS GLASS	<b>T6</b> TEMPERATURE CLASS
--------------------	----------------------	--	-------------------------------	-------------------------	--------------------------------

### PACKAGING

CODE	WEIGHT		PACKAGING			BOXES/EUROPALLET	
	KG	LBS	MM	INCH	PCS/BOX		
FO055A00	2,38	5,25	185X185X170	7,28X7,28X6,69	1	192	240
FO055B00	2,38	5,25	185X185X170	7,28X7,28X6,69	1	192	240
FO055C00	2,38	5,25	185X185X170	7,28X7,28X6,69	1	192	240
FO055D00	2,38	5,25	185X185X170	7,28X7,28X6,69	1	192	240



FILTRATION



TANK MONITORING



HOSE REEL



ACCESSORIES



MERCHANDISE

# PIUSI

INDEX

BIS

ANY BIODIESEL

A

AIR

A

ANTIFREEZE

Ad

AdBlue®

B

BIODIESEL

D

DIESEL

F

FOOD

G

GASOLINE

G

GREASE

K

KEROSENE

O

OIL

W

WATER

W

WINDSCREEN

## CHART

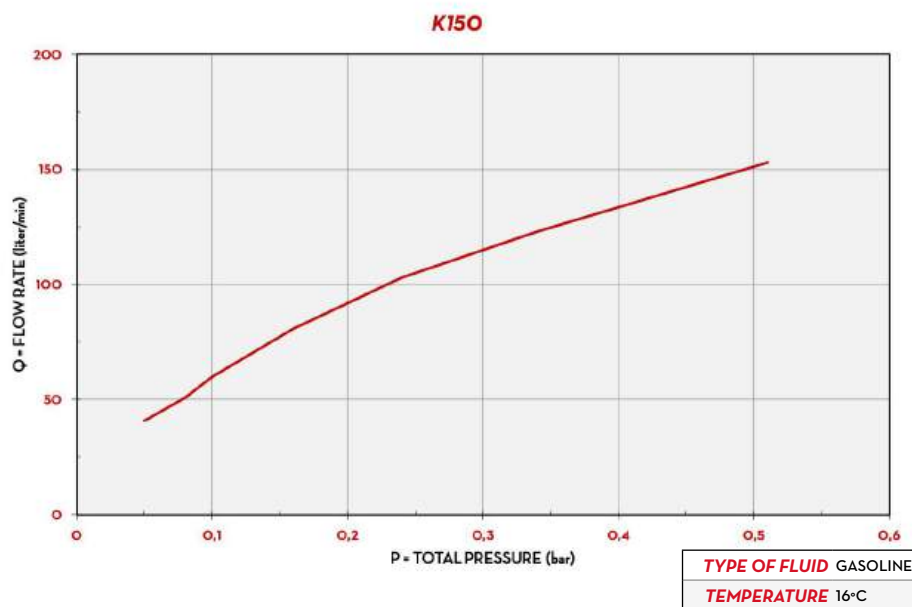

## DIMENSIONS

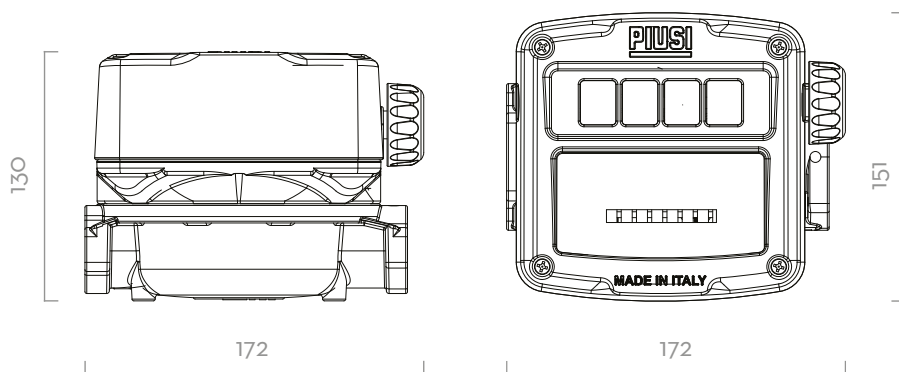

Dimensions expressed in millimeters

## IN THE BOX

- K150 ATEX METER
- INSTRUCTION MANUAL

## DETAILS



NUTATING DISK



4 FLOW DIRECTIONS



ATEX APPROVED



METALLIC COVER

## MATERIALS

- BODY AND COVER: ALUMINIUM
- NUTATING DISK CHAMBER: TECHNOPOLYMER

## TECHNICAL DATA

CODE	DESCRIPTION	FLUIDS TYPE	FLOW RATE		FLOW DIRECTIONS	PRESSURE		INLET/OUTLET
			L/MIN	GPM		BAR	PSI	
FO055A00	(EX) K150 METER VER.A ATEX	D G K	25-150	6,6-40	←	3,5	50	1" BSP
FO055B00	(EX) K150 METER VER.B ATEX	D G K	25-150	6,6-40	↑	3,5	50	1" BSP
FO055C00	(EX) K150 METER VER.C ATEX	D G K	25-150	6,6-40	↓	3,5	50	1" BSP
FO055D00	(EX) K150 METER VER.D ATEX	D G K	25-150	6,6-40	→	3,5	50	1" BSP

THE PIUSI K150 IS A MECHANICAL METER EXPRESSLY ENGINEERED FOR HEAVY DUTY AND HIGH FLOW RATE APPLICATIONS. IT IS EASY TO CALIBRATE AND READY-TO-USE; ITS ALUMINIUM COVER AND STURDY BODY MAKE THIS METER SUITABLE FOR A WIDE ARRANGE OF APPLICATIONS WHILE GUARANTEEING THE SAME PRECISION AND QUALITY THAT HAVE ALWAYS BEEN A FEATURE OF PIUSI EQUIPMENT.





FILTRATION



TANK MONITORING



HOSE REEL



ACCESSORIES



MERCHANDISE

# PIUSI

INDEX



ANY BIODIESEL



AIR



ANTIFREEZE



AdBlue®



BIODIESEL



DIESEL



FOOD



GASOLINE



GREASE



KEROSENE



OIL



WATER



WINDSCREEN

## CHART

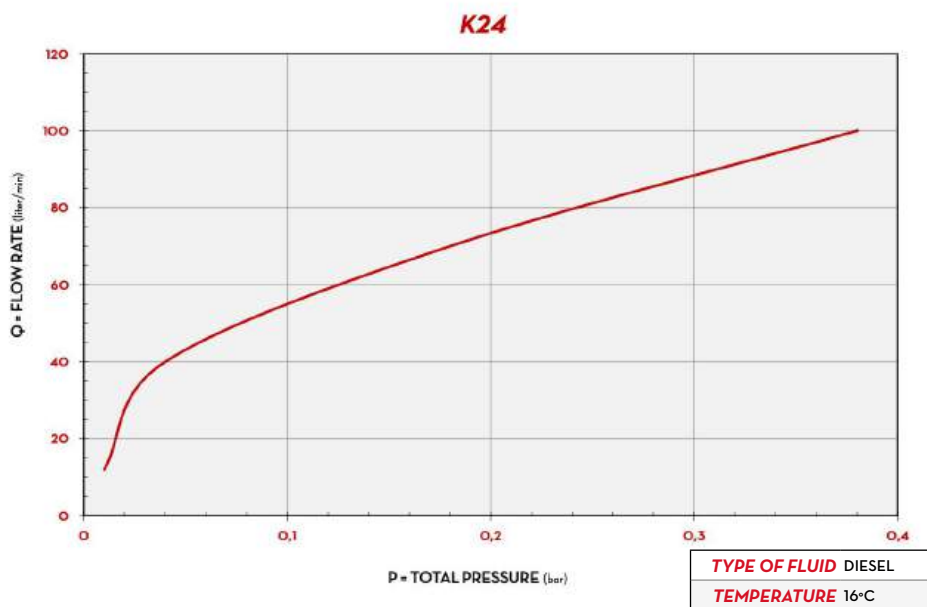

## DIMENSIONS

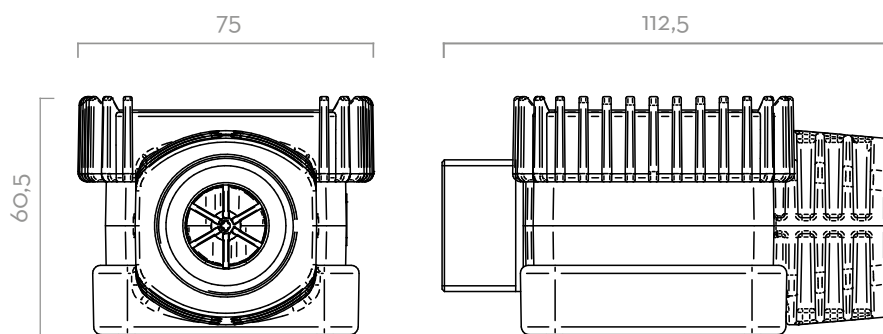

Dimensions expressed in millimeters

## TECHNICAL DATA

CODE	DESCRIPTION	FLUIDS TYPE	FLOW RATE		PRESSURE		BATTERY 2X AAA BATTERY 1,5V (INCLUDED)	FLANGE	INLET / OUTLET
			L/MIN	GPM	BAR	PSI			
<b>K24</b>									
FOO40700A	K24 METER M/MF LITER BLACK 1INBSP	D	7 - 120	2 - 32	10	150	YES	NO	M 1" BSP - M 1" BSP
FOO408100	K24 M/F 1" BSP	D	7 - 120	2 - 32	20	300	YES	NO	M 1" BSP - F 1" BSP
<b>K24 PULSER</b>									
FOO40722A	K24 PULSER M/MF LITER BLACK 1INBSP	D	7 - 120	2 - 32	10	150	NO	NO	M 1" BSP - M 1" BSP

UPON REQUEST AVAILABLE IN NPTF VERSION AND DISPLAY IN GALLON/QUARTER OR PRINT  
N° 2X1,5V BATTERY INCLUDED

## IN THE BOX

- K24 METER
- INSTRUCTION MANUAL

## DETAILS



## MATERIALS

- BODY: ALUMINIUM
- GEARS: TECHNOPOLYMER



FUEL MANAGEMENT SYSTEMS



DISPENSERS



KITS



PUMPS



METERS



NOZZLES

# K600/3

## FEATURES

- ADJUSTABLE FLANGES
- SUITABLE FOR INDUSTRIAL APPLICATIONS
- IDEAL FOR MOBILE INSTALLATIONS
- LOW ENERGY CONSUMPTIONS

The PIUSI K600/3 is an oval gear meter suitable for monitoring the delivery of diesel, oil and antifreeze. The meter is equipped with an integrated filter and is also available in pulser version.

### PERFORMANCE

UP TO <b>10-100 L/MIN</b>	<b>30 BAR</b> MAX
FLOW RATE	OPERATING PRESSURE
<b>± 0,5%</b>	<b>0,2%</b>
ACCURACY	REPEATABILITY



K600/3 METER



K600/3 PULSER

### PACKAGING

CODE	WEIGHT		PACKAGING		
	KG	LBS	MM	INCH	PCS/BOX
<b>METER</b>					
FOO496A00	1,6	3,5	200X120X140	7,9X4,7X5,5	1
<b>PULSER</b>					
FOO472A00	2,6	5,7	200X120X140	7,9X4,7X5,5	1





FILTRATION



TANK MONITORING



HOSE REEL



ACCESSORIES



MERCHANDISE



ANY BIODIESEL



AIR



ANTIFREEZE



AdBlue®



BIODIESEL



DIESEL



FOOD



GASOLINE



GREASE



KEROSENE



OIL



WATER



WINDSCREEN

### CHART

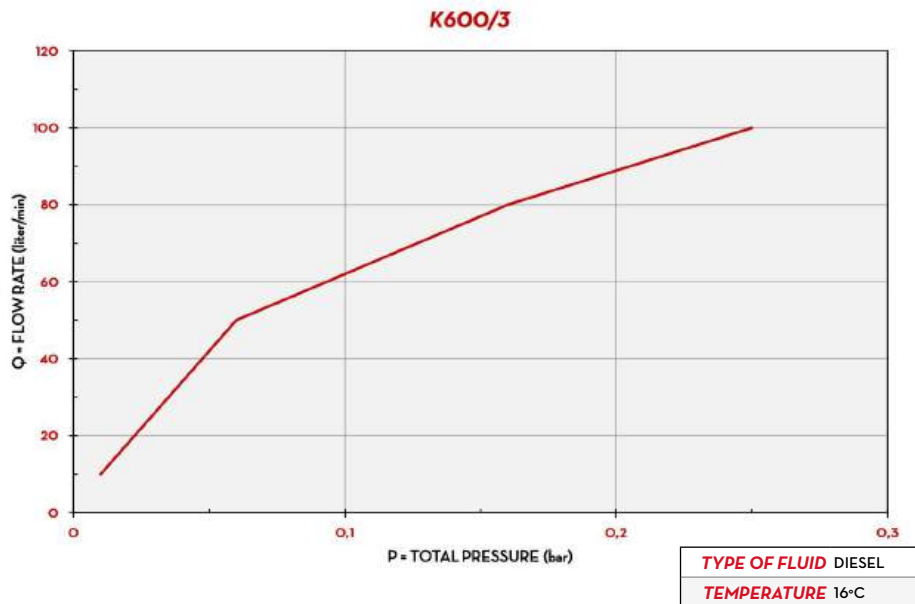

### IN THE BOX

- K600/3 METER
- FLANGES
- INSTRUCTION MANUAL

### DETAILS



5-DIGIT DISPLAY



OVAL GEARS

### DIMENSIONS

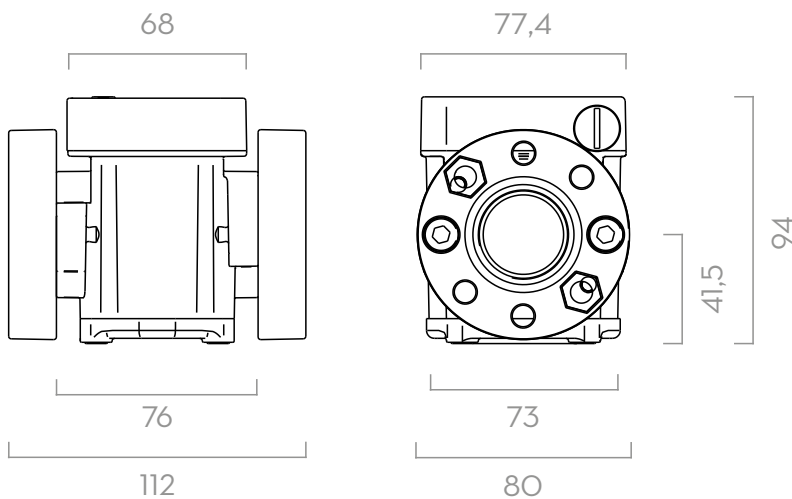

Dimensions expressed in millimeters

### MATERIALS

- BODY: ALUMINIUM
- GEARS: TECHNOPOLYMER

### TECHNICAL DATA

CODE	DESCRIPTION	FLUIDS TYPE	FLOW RATE		PRESSURE		BATTERY N°2 X 1,5V (INCLUDED)	FLANGE	INLET / OUTLET	INLET FILTER
			L/MIN	GPM	BAR	PSI				
<b>METER</b>										
FOO496A00	K600/3 METER 1" BSP DIESEL		10 - 100	2,64 - 26,4	30	426	YES	YES	1" BSP	YES
<b>PULSER</b>										
FOO472A00	K600/3 PULSER 1IN BSP DIESEL		10 - 100	2,64 - 26,4	30	426	NO	YES	1" BSP	YES

UPON REQUEST AVAILABLE IN NPTF VERSION AND DISPLAY IN GALLON/QUARTER OR PRINT



FUEL MANAGEMENT SYSTEMS



DISPENSERS



KITS



PUMPS



METERS



NOZZLES

# K600 B/3

## FEATURES

- BETTER VISIBILITY
- ADJUSTABLE FLANGES
- ROTATING DISPLAY
- STANDARD BATTERY
- PULSE-OUT VERSION AVAILABLE
- IP66

The PIUSI K600 B/3 is an oval gear meter suitable for monitoring the delivery of diesel, biodiesel and antifreeze. This special version includes a large 80mm built-in digital display that can be rotated to suit every application. Among its features: 5-digit partial total and resettable total. Pulser version available.

### PERFORMANCE

UP TO <b>10-100 L/MIN</b>	<b>30 BAR</b> MAX
FLOW RATE	OPERATING PRESSURE
<b>± 0,5%</b>	<b>0,2%</b>
ACCURACY	REPEATABILITY



K600 B/3 METER



K600 B/3 B100

### PACKAGING

CODE	WEIGHT		PACKAGING		
	KG	LBS	MM	INCH	PCS/BOX
FOO491000	2	4,4	200X120X140	7,9X4,7X5,5	1
FOO491000	2	4,4	200X120X140	7,9X4,7X5,5	1
FOO492000	2	4,4	200X120X140	7,9X4,7X5,5	1



FILTRATION



TANK MONITORING



HOSE REEL



ACCESSORIES



MERCHANDISE



ANY BIODIESEL



AIR



ANTIFREEZE



AdBlue®



BIODIESEL



DIESEL



FOOD



GASOLINE



GREASE



KEROSENE



OIL



WATER



WINDSCREEN

### CHART



**TYPE OF FLUID** DIESEL  
**TEMPERATURE** 16°C

### DIMENSIONS

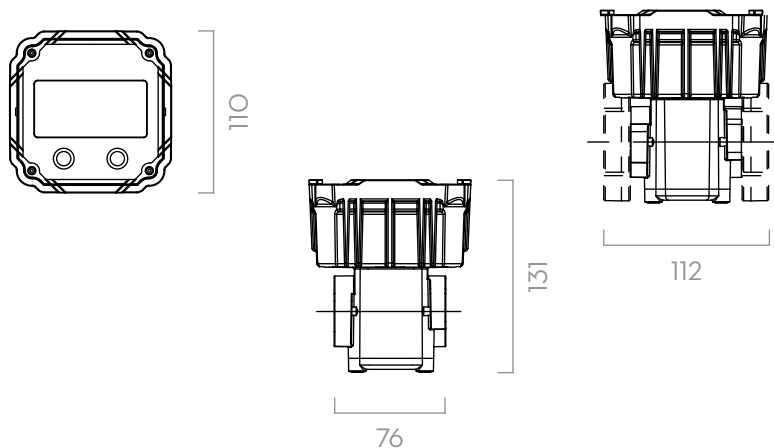

Dimensions expressed in millimeters

### IN THE BOX

- K600 B/3 METER
- FLANGES
- INSTRUCTION MANUAL

### DETAILS



### MATERIALS

- BODY: ALUMINIUM
- GEARS: TECHNOPOLYMER

### TECHNICAL DATA

CODE	DESCRIPTION	FLUIDS TYPE	FLOW RATE		PRESSURE		BATTERY N°2 X 1,5V (INCLUDED)	FLANGE	INLET / OUTLET	INLET FILTER
			L/MIN	GPM	BAR	PSI				
FOO491000	K600 B/3 METER 1" BSP		10 - 100	2,64 - 26,4	30	426	YES	YES	1" BSP	YES
FOO492000	K600 B / 3 1" BSP PULS OUT		10 - 100	2,64 - 26,4	30	426	YES	YES	1" BSP	YES
FOO492B00	K600 B/3 1" BSP PULS OUT B100		10 - 100	2,64 - 26,4	30	426	YES	YES	1" BSP	YES

UPON REQUEST AVAILABLE IN NPTF VERSION AND DISPLAY IN GALLON/QUARTER OR PRINT



FUEL MANAGEMENT SYSTEMS



DISPENSERS



KITS



PUMPS



METERS



NOZZLES

# K600/4

## FEATURES

- EASY TO INSTALL AND TO CALIBRATE
- VERSATILE
- HIGH PRECISION

The PIUSI K600/4 is an oval gear meter suitable for monitoring the delivery of fuels. This special version is particularly suitable for all applications in the industrial sector.

### PERFORMANCE

**15-150**

L/MIN

FLOW RATE

**20 BAR**

MAX

OPERATING PRESSURE

**± 0,5%**

ACCURACY

**0,2%**

REPEATABILITY



K600/4



K600/4 PULSER



### PACKAGING

CODE	WEIGHT		PACKAGING		
	KG	LBS	MM	INCH	PCS/BOX
<b>METER</b>					
00049700A	3,2	7	200X120X140	7,9X4,7X5,5	1
<b>PULSER</b>					
000473000	3,2	7	200X120X140	7,9X4,7X5,5	1



FILTRATION



TANK MONITORING



HOSE REEL



ACCESSORIES



MERCHANDISE



ANY BIODIESEL



AIR



ANTIFREEZE



AdBlue®



BIODIESEL



DIESEL



FOOD



GASOLINE



GREASE



KEROSENE



OIL



WATER



WINDSCREEN

### CHART

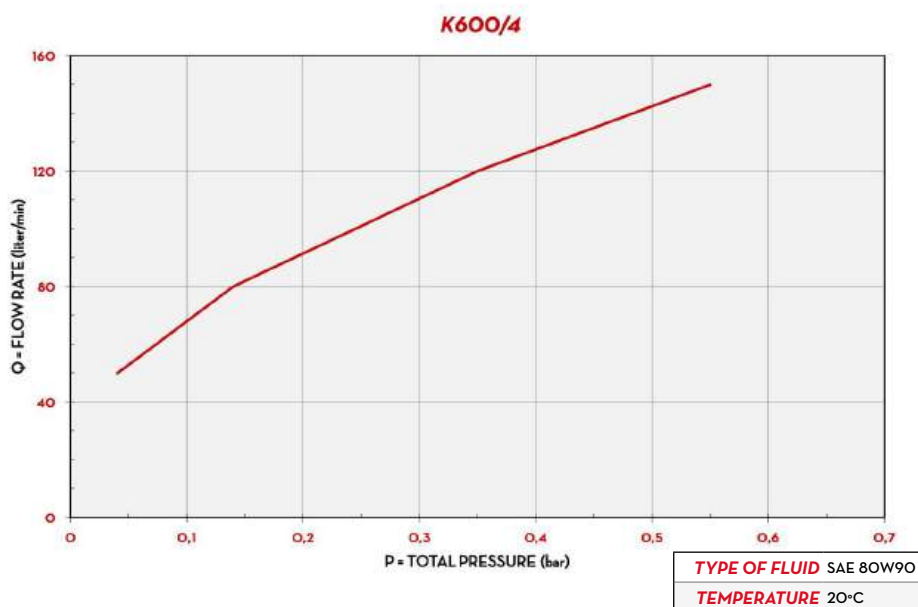

### IN THE BOX

- K600/4 METER
- FLANGES
- INSTRUCTION MANUAL

### DETAILS



5-DIGIT DISPLAY



OVAL GEARS

### DIMENSIONS

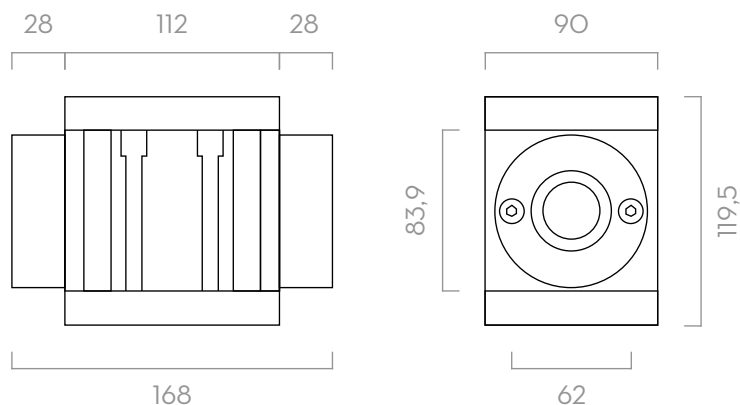

Dimensions expressed in millimeters

### MATERIALS

- BODY: ALUMINIUM
- GEARS: TECHNOPOLYMER

### TECHNICAL DATA

CODE	DESCRIPTION	FLUIDS TYPE	FLOW RATE		PULSER		PRESSURE		BATTERY N°2 X 1,5V (INCLUDED)	FLANGE	INLET / OUTLET	INLET FILTER
			L/MIN	GPM	P/L	GPM	BAR	PSI				
<b>METER</b> 00049700A	K600/4	A B D O	15 - 150	3,9 - 39	-	-	20	284	YES	YES	1 1/2" BSP	YES
<b>PULSER</b> 000473000	K600/4 PULSER	A B D O	15 - 150	3,9 - 39	26	98	20	300	NO	YES	1 1/2"	YES

UPON REQUEST AVAILABLE IN NPT VERSION.



FUEL MANAGEMENT SYSTEMS



DISPENSERS



KITS



PUMPS



METERS



NOZZLES

# K700 PULSER

## FEATURES

- EASY TO INSTALL AND TO CALIBRATE
- VERSATILE
- HIGH FLOW RATE
- HEAVY DUTY
- INDUSTRIAL APPLICATIONS

The PIUSI K700 PULSER is an oval gear electronic meter with acetal resin gears. This pulse meter easily interfaces with management systems, making it the ideal solution to fit fuel distributors. It is also suitable for tanks and cisterns, loading arms controlling the consumption of fuel in burners or generator sets, besides other applications.

### PERFORMANCE

**25-250**

L/MIN

FLOW RATE

**20 BAR**

MAX

OPERATING PRESSURE

**± 0,5%**

ACCURACY

**0,2%**

REPEATABILITY



K700 PULSER



### PACKAGING

CODE	WEIGHT		PACKAGING		
	KG	LBS	MM	INCH	PCS/BOX

#### PULSER

FOO49800A	5,5	12	280X160X140	11X6,3X5,5	1
-----------	-----	----	-------------	------------	---



FILTRATION



TANK MONITORING



HOSE REEL



ACCESSORIES



MERCHANDISE

# PIUSI

INDEX

B

ANY BIODIESEL

A

AIR

A

ANTIFREEZE

Ad

AdBlue®

B

BIODIESEL

D

DIESEL

F

FOOD

G

GASOLINE

G

GREASE

K

KEROSENE

O

OIL

W

WATER

W

WINDSCREEN

### CHART

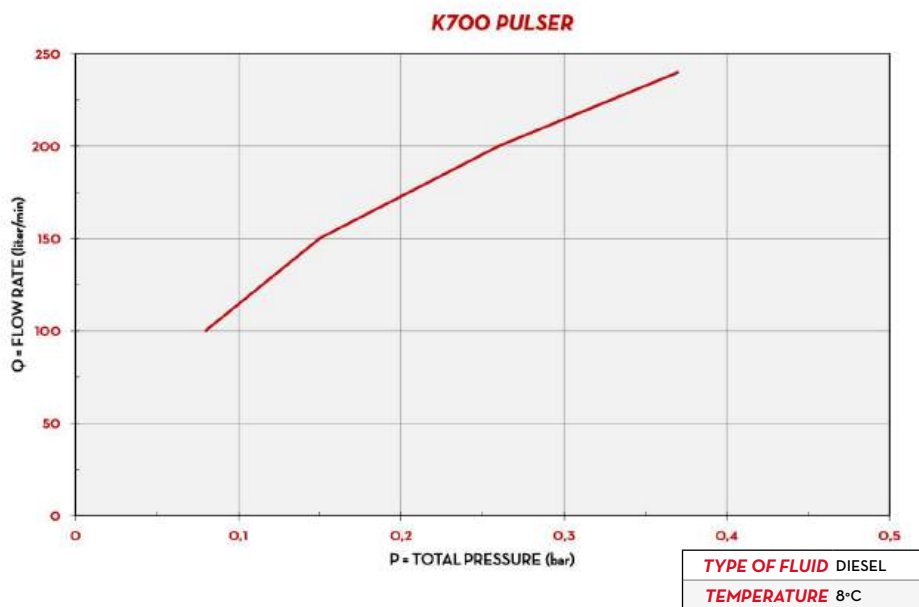

### IN THE BOX

- K700 PULSER METER
- INSTRUCTION MANUAL

### DETAILS



### DIMENSIONS

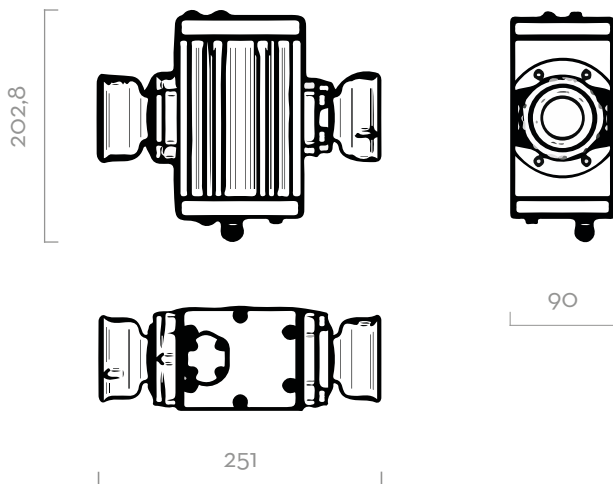

Dimensions expressed in millimeters

### MATERIALS

- BODY: ALUMINIUM
- GEARS: TECHNOPOLYMER

### TECHNICAL DATA

CODE	DESCRIPTION	FLUIDS TYPE	FLOW RATE		PULSER		PRESSURE		BATTERY N°2 X 1,5V (INCLUDED)	FLANGE	INLET / OUTLET	INLET FILTER
			L/MIN	GPM	P/L	GPM	BAR	PSI				
<b>FOO49800A</b>	K700 PULSER	<b>A B D O</b>	25 - 250	6,6 - 66	14	53	20	300	NO	YES	2" BSP	YES

#### PULSER

UPON REQUEST AVAILABLE IN NPT VERSION.



FUEL MANAGEMENT SYSTEMS



DISPENSERS



KITS



PUMPS



METERS



NOZZLES

# K900

## FEATURES

- STURDY STRUCTURE
- HEAVY DUTY CONDITIONS
- HIGH FLOW RATE APPLICATIONS
- READY TO INSTALL

Among the electronic flow meters Made in Italy by PIUSI, the K900 is the oval gear measuring equipment suitable for controlling the non commercial dispensing of low, medium and high viscosity fluids compatible with its construction materials. This meter is equipped with an in-built suction filter, 3" inlet/outlet and free contact signal pulser.

### PERFORMANCE

**50-500**

L/MIN

FLOW RATE

**20 BAR**

MAX

OPERATING PRESSURE

**±0,5%**

ACCURACY

**0,2%**

REPEATABILITY



K900



### PACKAGING

CODE	WEIGHT		PACKAGING		
	KG	LBS	MM	INCH	PCS/BOX
<b>METER</b>					
<b>FOO49900B</b>	12	26,5	400X290X200	15,7X11,4X7,9	1
<b>PULSER</b>					
<b>FOO49902B</b>	12	26,5	400X290X200	15,7X11,4X7,9	1





FILTRATION



TANK MONITORING



HOSE REEL



ACCESSORIES



MERCHANDISE



ANY BIODIESEL



AIR



ANTIFREEZE



AdBlue®



BIODIESEL



DIESEL



FOOD



GASOLINE



GREASE



KEROSENE



OIL



WATER



WINDSCREEN

### CHART

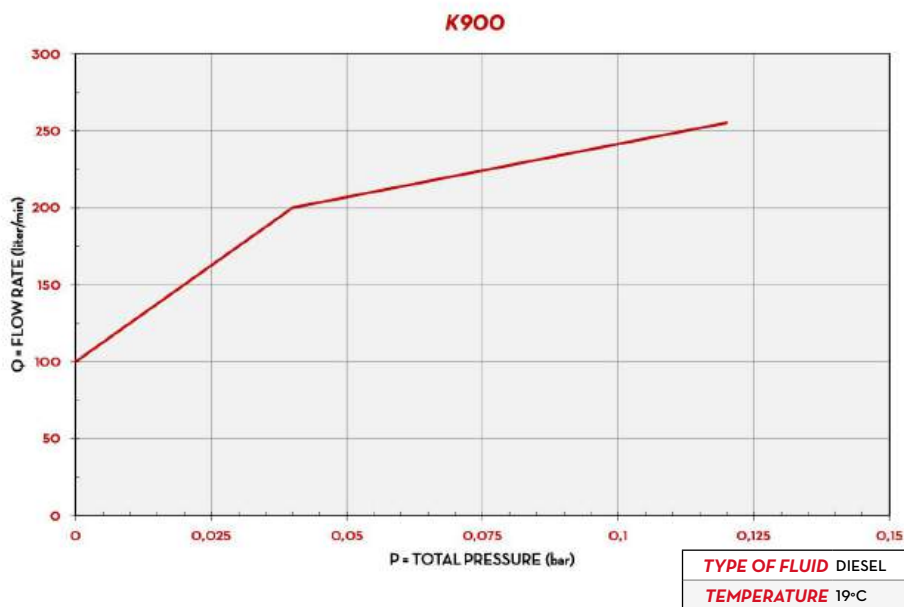

### DIMENSIONS

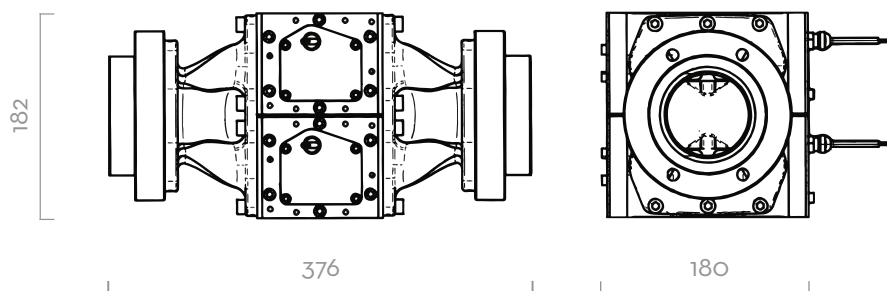

Dimensions expressed in millimeters

### IN THE BOX

- K900 METER
- INSTRUCTION MANUAL

### DETAILS



INBUILT FILTER



OVAL GEARS



5 DIGIT PARTIAL TOTAL



IN/OUT 3"

### MATERIALS

- BODY: ALUMINIUM
- GEARS: TECHNOPOLYMER

### TECHNICAL DATA

CODE	DESCRIPTION	FLUIDS TYPE	FLOW RATE		PULSER		PRESSURE		BATTERY N°2 X 1,5V (INCLUDED)	FLANGE	INLET / OUTLET	INLET FILTER
			L/MIN	GPM	P/L	GPM	BAR	PSI				
<b>METER</b> FOO49900B	K900	<b>B</b> <b>D</b>	50 - 500	13,2 - 132	-	-	20	284	YES	YES	3" BSP	YES
<b>PULSER</b> FOO49902B	K900 PULSER	<b>B</b> <b>D</b>	50 - 500	13,2 - 132	10	38	20	284	YES	YES	3" BSP	YES

UPON REQUEST AVAILABLE IN NPT VERSION. DISPLAY POWER SUPPLY 4-12VDC, 1,2 AMP. TYPE OF OUTPUT SIGNAL: OPEN COLLECTOR MAX 50V, 1,2 AMP, SINGLE CHANNEL.



FUEL MANAGEMENT SYSTEMS



DISPENSERS



KITS



PUMPS



METERS



NOZZLES

# REMOTE DISPLAY

## FEATURES

- LARGE SCREEN DISPLAY
- NON RESETTABLE TOTAL
- STANDARD BATTERY

REMOTE DISPLAY for remote control (via max. 15 m. cable) of pulse meters. The large screen displays the quantity delivered and the non resettable total. Equipped with software applications for calibrating meters. Available as both basic display device and as pulse emitter. Indispensable for receivers designed to recognise only discreet quantities of impulses. The easy interfacing management systems of the pulse transmitter models extend the field of application of pulse meters combined with remote displays.

### PERFORMANCE

every

**PULSE METER**

COMPATIBILITY

UP TO

**100**

PULSES/LITER



REMOTE DISPLAY



### PACKAGING

CODE	WEIGHT		PACKAGING		
	KG	LBS	MM	INCH	PCS/BOX
F117520OB	1,2	2,6	200X120X140	7,9X4,7X5,5	1
F117530OB	1,2	2,6	200X120X140	8,9X4,9X5,9	1
F117540OB	1,2	2,6	200X120X140	8,9X4,9X5,9	1
FOO49501A	1,2	2,6	200X120X140	8,9X4,9X5,9	1
FOO49502A	1,2	2,6	200X120X140	8,9X4,9X5,9	1



FILTRATION



TANK MONITORING



HOSE REEL



ACCESSORIES



MERCHANDISE

# PIUSI

INDEX



ANY BIODIESEL



AIR



ANTIFREEZE



AdBlue®



BIODIESEL



DIESEL



FOOD



GASOLINE



GREASE



KEROSENE



OIL



WATER



WINDSCREEN

### CHART

Remote display battery powered

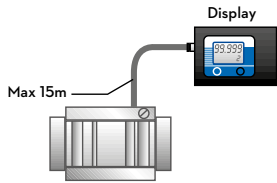

Remote display battery powered

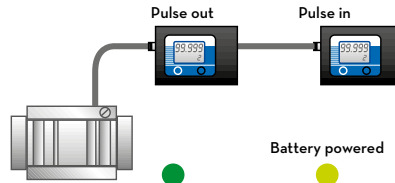

Display pulse transmitter battery powered

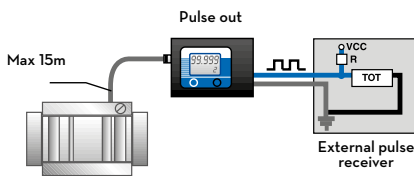

Display pulse transmitter externally powered

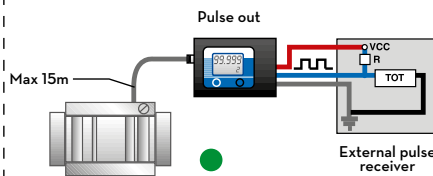

### IN THE BOX

- REMOTE DISPLAY UNIT
- BRACKET ADJUSTABLE
- INSTRUCTION MANUAL

### DETAILS



5 DIGITS PARTIAL TOTAL

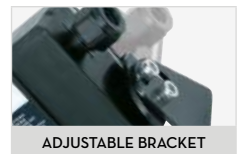

ADJUSTABLE BRACKET

### DIMENSIONS

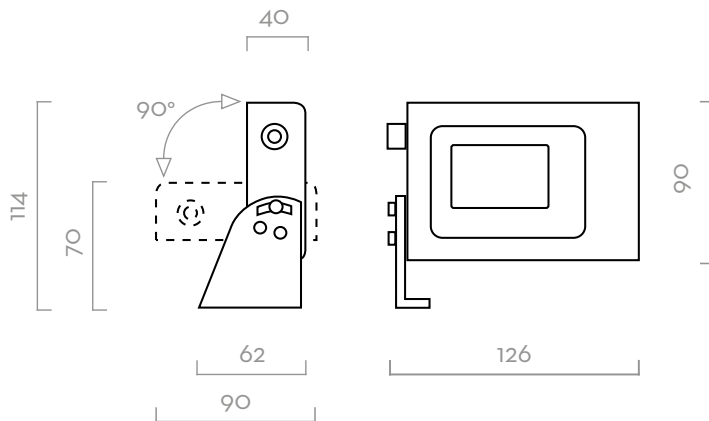

Dimensions expressed in millimeters

### TECHNICAL DATA

CODE	DESCRIPTION	FLUIDS TYPE	METERS	INLET OUTLET
F1175200B	REMOTE DISPLAY PULSE OUT K600	Ad B D O W W	K600 DIESEL	PULSE OUT ●
F1175300B	REMOTE DISPLAY PULSE OUT K600/4	Ad B D O W W	K600/4	PULSE OUT ●
F1175400B	REMOTE DISPLAY PULSE OUT K700	Ad B D O W W	K700	PULSE OUT ●
FO049501A	REMOTE DISPLAY PULSE OUT UNIVERSAL	Ad B D O W W	K200, K400, K600 OIL, K600 DIESEL, K600/4, K700	PULSE OUT ●
FO049502A	UNIVERSAL REMOTE DISPLAY PULSE IN	Ad B D O W W	FOR ALL PIUSI PULSE OUT REMOTE DISPLAY	PULSE IN ●



FUEL MANAGEMENT SYSTEMS



DISPENSERS



KITS



PUMPS



METERS



NOZZLES

# K90

## FEATURES

- EASY TO CALIBRATE
- RELIABILITY AND ACCURACY: TESTED FOR MORE THAN 4 MILLION LITERS DISPENSED
- HIGH VISIBILITY 3-DIGIT NUMERIC DISPLAY AND 7-DIGIT TOTALIZER
- 90° IN-OUT FLOW: ALLOWS THE USER TO AVOID THE USE OF ADDITIONAL FITTINGS IN THE DISPENSING SYSTEM
- NO BATTERY NEEDED

The new PIUSI K90 flow meters enters the high-precision range: the accurate mechanical meter is ideal for environments requiring a compact, simple and easy to install product. It is suitable for a wide range of industries, from construction to logistics, agriculture or mining. The PIUSI K90 can be installed on fuel transfer systems with flow rates from 20 to 90 l/min, and thanks to its accuracy of  $\pm 0.6\%$  in the 50-70 l/min dispensing range, it is positioned as one of the most accurate solutions in the mechanical flow meter segment.

### PERFORMANCE

**20-90 L/MIN**

FLOW RATE

**3,5 BAR**

WORKING PRESSURE MAX.

**$\pm 0,6\%$**

(RANGE 50-70 L/MIN)

ACCURACY

**$\pm 0,3\%$**

REPEATIBILITY



**K90**  
(No threaded flanges.)



**FLUID DIRECTION**

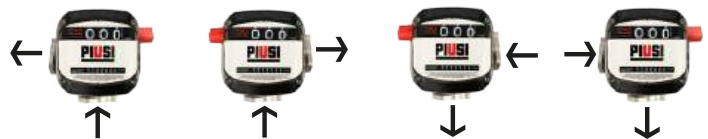

CODE	FO09SW000	FO09SE000	FO09ES000	FO09WS000
SUCTION	Below	Below	Right	Left
DELIVERY	Left	Right	Below	Below

### PACKAGING

CODE	WEIGHT		PACKAGING			N. BOX / EUROPALLET	
	KG	LBS	MM	INCH	PCS/BOX		
FO09ES000	2,068	4,55	180X180X170	7,28X7,28X6,69	1	192	240
FO09SE000	2,068	4,55	180X180X170	7,28X7,28X6,69	1	192	240
FO09SW000	2,068	4,55	180X180X170	7,28X7,28X6,69	1	192	240
FO09WS000	2,068	4,55	180X180X170	7,28X7,28X6,69	1	192	240



FILTRATION



TANK MONITORING



HOSE REEL



ACCESSORIES



MERCHANDISE

# PIUSI

INDEX

B

ANY BIODIESEL

A

AIR

A

ANTIFREEZE

Ad

AdBlue®

B

BIODIESEL

D

DIESEL

F

FOOD

G

GASOLINE

G

GREASE

K

KEROSENE

O

OIL

W

WATER

W

WINDSCREEN

## CHART

### K90

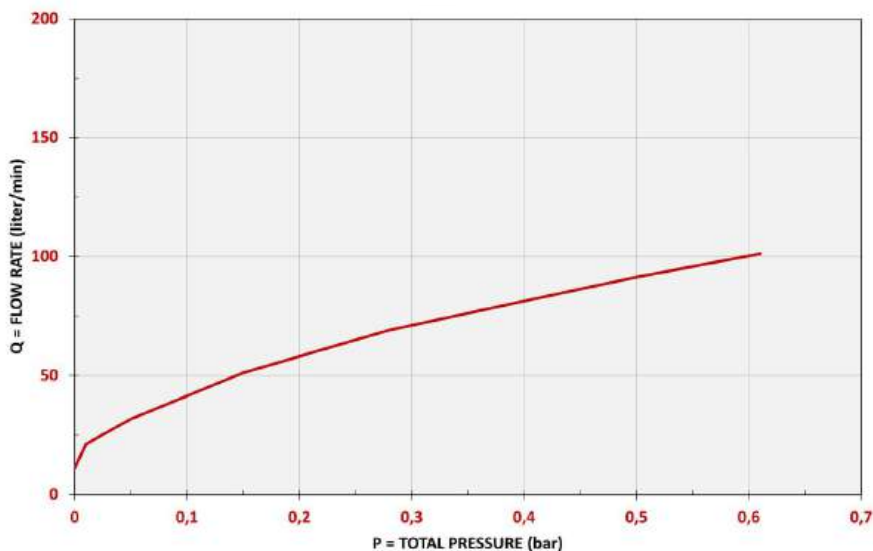

## DIMENSIONS

TYPE OF FLUID DIESEL

TEMPERATURE 14,8°C

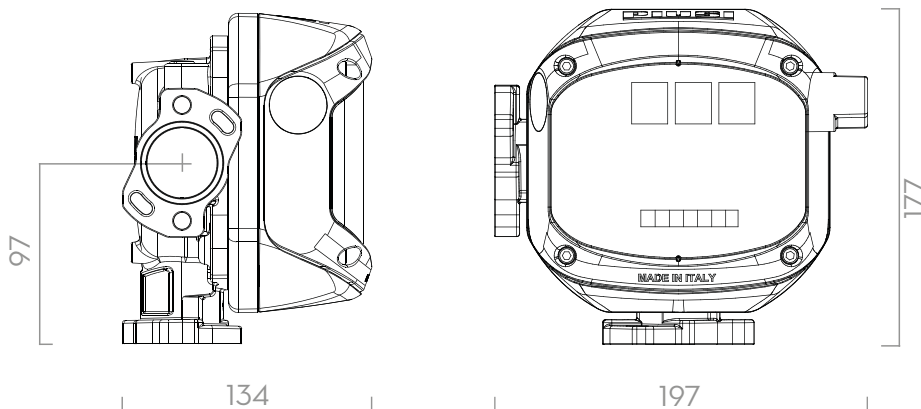

Dimensions expressed in millimeters

## IN THE BOX

- K90 METER
- INSTRUCTION MANUAL

## DETAILS



INLET & OUTLET FLOW DIRECTION



UNTHREADED INLET/OUTLET



NUTATING DISK SYSTEM

## MATERIALS

- BODY: ALUMINIUM
- NUTATING DISK CHAMBER: TECHNOPYLIMER

## TECHNICAL DATA

CODE	DESCRIPTION	FLUIDS TYPE	FLOW RATE		PRESSURE		ACCURACY		INLET/OUTLET
			L/MIN	GPM	BAR	PSI	20-90 L/MIN	50-70 L/MIN	
FO09ES000	CONTALITRI K90 - VER. ES	D	20-90 l/min	5-24 GPM	3,5	50	± 0,8%	± 0,6%	Ø 29,5
FO09SE000	CONTALITRI K90 - VER. SE	D	20-90 l/min	5-24 GPM	3,5	50	± 0,8%	± 0,6%	Ø 29,5
FO09SW000	CONTALITRI K90 - VER. SW	D	20-90 l/min	5-24 GPM	3,5	50	± 0,8%	± 0,6%	Ø 29,5
FO09WS000	CONTALITRI K90 - VER. WS	D	20-90 l/min	5-24 GPM	3,5	50	± 0,8%	± 0,6%	Ø 29,5



FUEL MANAGEMENT SYSTEMS



DISPENSERS



KITS



PUMPS



METERS



NOZZLES

# K33 / K44

## FEATURES

- **READY TO USE**
- **BURSTING PRESSURE 28 BAR**
- **NO BATTERY NEEDED**
- **EASY TO INSTALL AND CALIBRATE**
- **4 FLOW DIRECTION**

The PIUSI K33 and K44 are the bestseller mechanical meters in this market. Reliable, easy to install and to calibrate, they are equipped with a nutating disk that allows them to be installed in all four flow directions. The display is available in both three or four digits, according to the model chosen.

### PERFORMANCE

**20-120**

L/MIN  
FLOW RATE

**3,5 BAR**

MAX OPERATING  
PRESSURE

**±1%**

ACCURACY

**±0,3%**

REPEATIBILITY



K33

K44



K33 BIO



### PACKAGING

CODICE	PESO		PACKAGING			N. BOX / EUROPALLET	
	KG	LBS	MM	INCH	PCS/BOX	✈	🚚

#### METER

000550000	2,06	4,55	180X180X170	-	1	192	240
000551000	2,06	4,55	180X180X170	-	1	192	240
000552000	2,06	4,55	180X180X170	-	1	192	240
000553000	2,06	4,55	180X180X170	-	1	192	240
000560000	2,08	4,58	180X180X170	-	1	192	240
000561000	2,08	4,58	180X180X170	-	1	192	240
000562000	2,08	4,58	180X180X170	-	1	192	240
000563000	2,08	4,58	180X180X170	-	1	192	240
FO0550B00	2,06	4,55	180X180X170	-	1	192	240

#### PULSER

00056500A	2,14	4,73	180X180X170	-	1	192	240
-----------	------	------	-------------	---	---	-----	-----



FILTRATION



TANK MONITORING



HOSE REEL



ACCESSORIES



MERCHANDISE

**PIUSI**

INDEX



ANY BIODIESEL



AIR



ANTIFREEZE



AdBlue®



BIODIESEL



DIESEL



FOOD



GASOLINE



GREASE



KEROSENE



OIL



WATER



WINDSCREEN

CHART

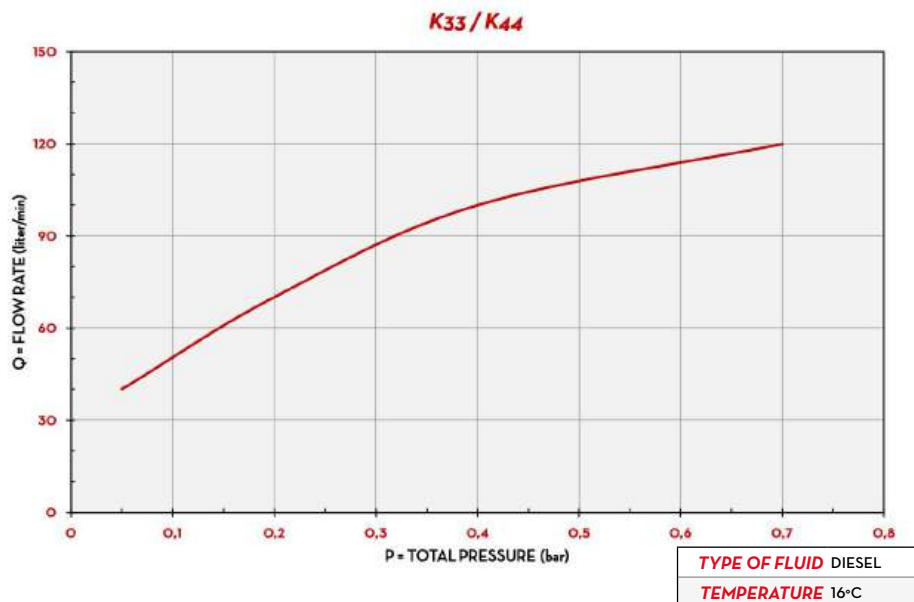

IN THE BOX

- K33 / K44 METER
- INSTRUCTION MANUAL

DETAILS



NUTATING DISK SYSTEM



4 FLOW DIRECTIONS

DIMENSIONS

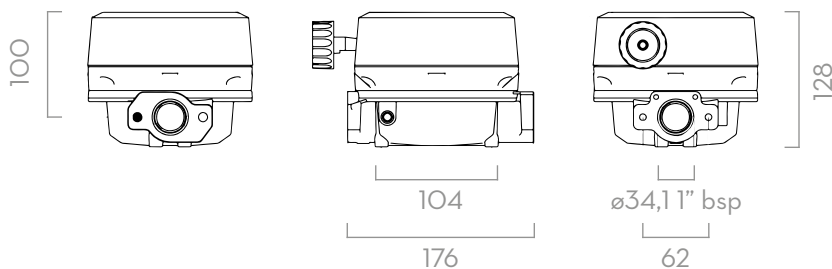

Dimensions expressed in millimeters

MATERIALS

- BODY: ALUMINIUM
- NUTATING DISK CHAMBER: TECHNOPYMER

TECHNICAL DATA

CODE	DESCRIPTION	FLUIDS TYPE	FLOW DIRECTION	FLOW RATE		PRESSURE		PULSER P/L (P/GAL)	INLET / OUTLET
				L/MIN	GPM	BAR	PSI		
<b>METER</b>									
000550000	K33 VER. A	D	←	20 - 120	5 - 32	3,5	50	-	1" BSP
000551000	K33 VER. B	D	↑	20 - 120	5 - 32	3,5	50	-	1" BSP
000552000	K33 VER. C	D	↓	20 - 120	5 - 32	3,5	50	-	1" BSP
000553000	K33 VER. D	D	→	20 - 120	5 - 32	3,5	50	-	1" BSP
000560000	K44 VER. A	D	←	20 - 120	5 - 32	3,5	50	-	1" BSP
000561000	K44 VER. B	D	↑	20 - 120	5 - 32	3,5	50	-	1" BSP
000562000	K44 VER. C	D	↓	20 - 120	5 - 32	3,5	50	-	1" BSP
000563000	K44 VER. D	D	→	20 - 120	5 - 32	3,5	50	-	1" BSP
FO0550B00	K33 1" BSP VER.A B100	BIO D	←	20 - 120	5 - 32	3,5	50	-	1" BSP
<b>PULSER</b>									
00056500A	K44 PULSER	D	→	20 - 120	5 - 32	3,5	50	10 (38)	1" BSP



FUEL MANAGEMENT SYSTEMS



DISPENSERS



KITS



PUMPS



METERS



NOZZLES

# K150

## FEATURES

- HEAVY DUTY CONDITIONS
- HIGH FLOW RATE
- BURSTING PRESSURE 28 BAR
- EASY READING
- 4 FLOW DIRECTIONS

K150 is expressly engineered to meet the market requirements of a meter suitable for flow rates superior than 120 l/min and that can be used both for fluids such as diesel and biodiesel, as well as in potentially explosives atmosphere; with gasoline for example. K150 is easy to calibrate and ready to use; its aluminium cover and sturdy body make this meter suitable for a wide arrange of application while guaranteeing the same precision and quality that have always featured PIUSI equipment. The mechanical display allows to read quickly the quantity dispensed. It can be installed everywhere thanks to the (optional) 1,5" flange kit.

### PERFORMANCE

UP TO <b>25-150</b> L/MIN FLOW RATE	<b>3,5 BAR</b> MAX OPERATING PRESSURE
<b>± 1%</b> ACCURACY	<b>0,3%</b> REPEATABILITY



K150



K150 BIO



### PACKAGING

CODE	WEIGHT		PACKAGING			BOXES/EUOPALLET	
	KG	LBS	MM	INCH	PCS/BOX	X	
FO0554A00	2,38	5,25	185X185X170	7,28X7,28X6,69	1	192	240
FO0554B00	2,38	5,25	185X185X170	7,28X7,28X6,69	1	192	240
FO0554C00	2,38	5,25	185X185X170	7,28X7,28X6,69	1	192	240
FO0554D00	2,38	5,25	185X185X170	7,28X7,28X6,69	1	192	240
FO0554B10	2,38	5,25	185X185X170	7,28X7,28X6,69	1	192	240





FILTRATION



TANK MONITORING



HOSE REEL



ACCESSORIES



MERCHANDISE

# PIUSI

INDEX



ANY BIODIESEL



AIR



ANTIFREEZE



AdBlue®



BIODIESEL



DIESEL



FOOD



GASOLINE



GREASE



KEROSENE



OIL



WATER



WINDSCREEN

## CHART



## DIMENSIONS

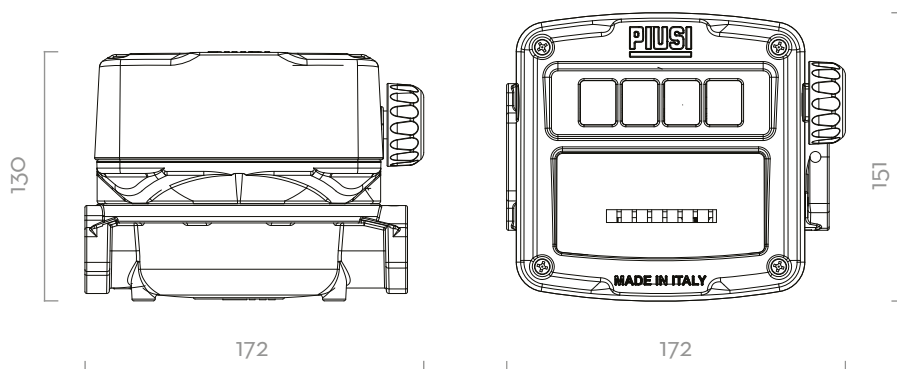

Dimensions expressed in millimeters

## IN THE BOX

- K150 METER
- INSTRUCTION MANUAL

## DETAILS



NUTATING DISK



4 FLOW DIRECTIONS



METALLIC COVER

## MATERIALS

- BODY AND COVER: ALUMINIUM
- NUTATING DISK CHAMBER: TECHNOPYLIMER

## TECHNICAL DATA

CODE	DESCRIPTION	FLUIDS TYPE	FLOW RATE		FLOW DIRECTIONS	PRESSURE		INLET/OUTLET
			L/MIN	GPM		BAR	PSI	
FO0554A00	K150 METER LITERS - 1" BSP VER.A	D	25-150	6,6-40	←	3,5	50	1" BSP
FO0554B00	K150 METER LITERS - 1" BSP VER.B	D	25-150	6,6-40	↑	3,5	50	1" BSP
FO0554C00	K150 METER LITERS - 1" BSP VER.C	D	25-150	6,6-40	↓	3,5	50	1" BSP
FO0554D00	K150 METER LITERS - 1" BSP VER.D	D	25-150	6,6-40	→	3,5	50	1" BSP
FO0554B10	K150 - 1" BSP VER.A B100	BIO D	25-150	6,6-40	←	3,5	50	1" BSP

THE PIUSI K150 IS A MECHANICAL METER EXPRESSLY ENGINEERED FOR HEAVY DUTY AND HIGH FLOW RATE APPLICATIONS. IT IS EASY TO CALIBRATE AND READY-TO-USE; ITS ALUMINIUM COVER AND STURDY BODY MAKE THIS METER SUITABLE FOR A WIDE ARRANGE OF APPLICATIONS WHILE GUARANTEEING THE SAME PRECISION AND QUALITY THAT HAVE ALWAYS BEEN A FEATURE OF PIUSI EQUIPMENT.



FUEL MANAGEMENT SYSTEMS



DISPENSERS



KITS



PUMPS



METERS



NOZZLES

# K700

## FEATURES

- HEAVY DUTY CONDITIONS
- STURDY STRUCTURE
- BURSTING PRESSURE 30 BAR
- NO BATTERY NEEDED
- EASY TO INSTALL
- 2 FLOW DIRECTION

Medium-high flow rates require specific measuring equipment able to adapt precisely to the flow: It is the case of the oval gear mechanical flow meter PIUSI K700: a sturdy, reliable and easy to install equipment suitable for the most demanding environments. The meter displays 4-digit piece of equipment partial total that can show up to a maximum of 9999 liters.

### PERFORMANCE

**40-220**

L/MIN

FLOW RATE

**10 BAR**

MAX OPERATING

PRESSURE

**± 1,5%**

ACCURACY

**0,3%**

REPEATABILITY



K700



### PACKAGING

CODE	WEIGHT		PACKAGING			N. BOXES / EUROPALLET	
	KG	LBS	MM	INCH	PCS/BOX	✈	🚚
FO0540000	5,8	12,8	240X240X275	-	1	48	72
FO0540020	5,8	12,8	240X240X275	-	1	48	72
FO0540030	5,8	12,8	240X240X275	-	1	48	72
FO0540040	5,8	12,8	240X240X275	-	1	48	72



FILTRATION



TANK MONITORING



HOSE REEL



ACCESSORIES



MERCHANDISE



ANY BIODIESEL



AIR



ANTIFREEZE



AdBlue®



BIODIESEL



DIESEL



FOOD



GASOLINE



GREASE



KEROSENE



OIL



WATER



WINDSCREEN

### CHART

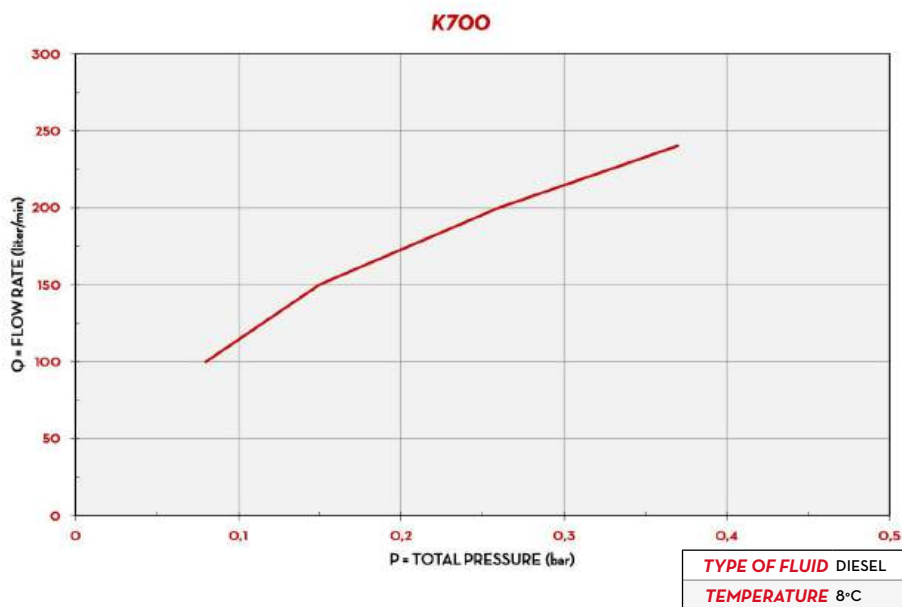

### DIMENSIONS

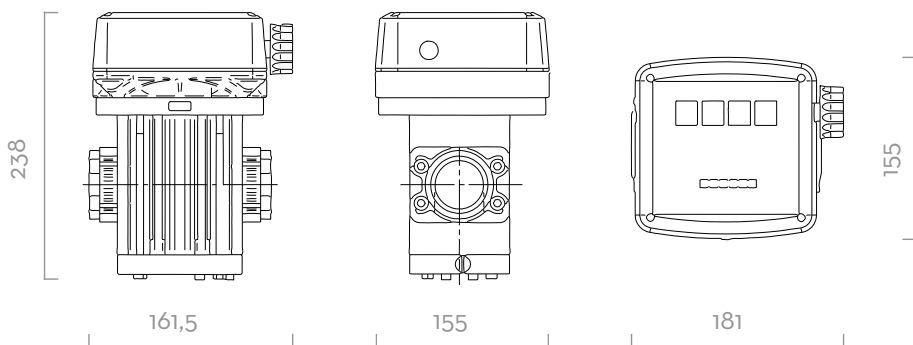

Dimensions expressed in millimeters

### IN THE BOX

- K700 METER
- INSTRUCTION MANUAL

### DETAILS



### MATERIALS

- BODY: ALUMINIUM
- GEARS: TECHNOPOLYMER



### TECHNICAL DATA

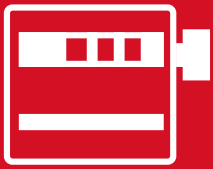

CODE	DESCRIPTION	FLUIDS TYPE	FLOW DIRECTION	FLOW RATE		PRESSURE		INLET FILTER	INLET / OUTLET
				L/MIN	GPM	BAR	PSI		
FO0540000	K700 VER. A	D		40 - 220	5 - 53	10	142	YES	1" 1/2 BSP
FO0540020	K700 VER. B	D		40 - 220	5 - 32	10	142	YES	1" 1/2 BSP
FO0540030	K700 VER. C	D		40 - 220	5 - 53	10	142	YES	1" 1/2 BSP
FO0540040	K700 VER. D	D		40 - 220	5 - 32	10	142	YES	1" 1/2 BSP







# METERS ACCESSORIES



## ELECTRONIC METERS

K24 PULSER	CODICE	DESCRIZIONE
	FOO49501A	REMOTE DISPLAY PULS OUT UNIVERSAL
	FOO49502A	UNIVERSAL REMOTE DISPLAY PULS IN
		 FOO49501A FOO49502A

K600/3 PULSER	CODICE	DESCRIZIONE
	FOO49501A	DISPLAY REMOTO PULS OUT UNIVERSALE
	FOO49502A	DISPLAY REMOTO PULS IN UNIVERSALE
	F1175200B	REMOTE DISPLAY PULS OUT K600/3 LT SEL
		 FOO49501A FOO49502A

K600/4 PULSER	CODICE	DESCRIZIONE
	FOO49501A	REMOTE DISPLAY PULS OUT UNIVERSAL
	FOO49502A	UNIVERSAL REMOTE DISPLAY PULS IN
	F1175300B	REMOTE DISPLAY PULS OUT K600/4 LT SEL
		 FOO49501A FOO49502A F1175300B

K700	CODICE	DESCRIZIONE
	FOO49501A	REMOTE DISPLAY PULS OUT UNIVERSAL
	FOO49502A	UNIVERSAL REMOTE DISPLAY PULS IN
	F1175400B	REMOTE DISPLAY PULS OUT K700 LT SEL
		 FOO49501A FOO49502A F1175400B

K900	CODICE	DESCRIZIONE
	RT152600A	KIT DR K900 W PULS OUT
	RT146400A	KIT DR K900 W/O PULS OUT
		 RT152600A RT146400A





# **NOZZLES**

A large, solid red triangle is positioned in the bottom right corner of the page, pointing towards the top right.



FUEL MANAGEMENT SYSTEMS



DISPENSERS



KITS



PUMPS



METERS



NOZZLES

# A60 / A140 ATEX

## FEATURES

- AUTOMATIC
- READY TO USE
- STURDY DESIGN

Expressly engineered to meet the strictest requirements of the ATEX/IECEX regulations, the PIUSI A60/A140 ATEX is an automatic nozzle suitable to dispense fluids - such as gasoline, kerosene, diesel and others - in potentially explosive atmospheres. It is fitted with a structural component that automatically stops dispensing when the tank is full.

### PERFORMANCE

UP TO <b>140 L/MIN</b>	<b>1" BSP</b>
FLOW RATE	INLET
<b>A60</b> <b>Ø21MM</b>	<b>A140</b> <b>Ø29MM</b>
SPOUT	SPOUT



A60 ATEX



A140 ATEX



### PACKAGING

CODE		WEIGHT		PACKAGING			BOXES/EUROPALLET	
WITHOUT SWIVEL	WITH SWIVEL	KG	LBS	MM	INCH	PCS/BOX		
<b>A60 ATEX</b>								
-	<b>F00613020</b>	1,25	2,76	460X200X80	181X78X31	1	-	-
<b>A140 ATEX</b>								
-	<b>F22675000</b>	2,00	4,41	460X200X80	181X78X31	1	-	-





FILTRATION



TANK MONITORING



HOSE REEL



ACCESSORIES



MERCHANDISE

# PIUSI

INDEX

B

ANY BIODIESEL

A

AIR

A

ANTIFREEZE

Ad

AdBlue®

B

BIODIESEL

D

DIESEL

F

FOOD

G

GASOLINE

G

GREASE

K

KEROSENE

O

OIL

W

WATER

W

WINDSCREEN

## CHART

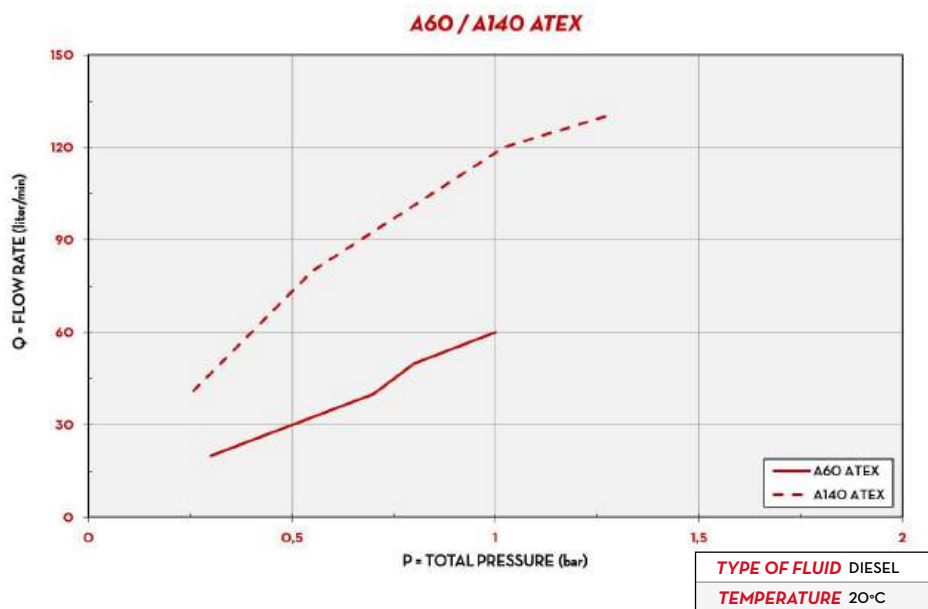

## IN THE BOX

- A60 / A140 ATEX NOZZLE
- INSTRUCTION MANUAL

## DETAILS



AUTOMATIC STOP



F1" SWIVEL (ONLY A60 ATEX)

## MATERIALS

- BODY: ALUMINIUM
- SEAL: NBR

## TECHNICAL DATA

CODE		DESCRIPTION	FLUIDS TYPE	FLOW RATE		INLET		SPOUT
WITHOUT SWIVEL	WITH SWIVEL			L/MIN	GPM	WITHOUT SWIVEL BSP	WITH SWIVEL BSP	EXT. Ø MM
<b>A60 ATEX</b>								
-	F00613020	A60 ATEX	D G K	60	16	-	F1"	21
<b>A140 ATEX</b>								
F22675000	-	(EX) AUTOMATIC NOZZLE A140 W\OUT SWIVEL	D G K	140	37	F1"	-	29



FUEL MANAGEMENT SYSTEMS



DISPENSERS



KITS



PUMPS



METERS



NOZZLES

# A60 / A80 / A120 / A140

## FEATURES

- AUTOMATIC
- READY TO USE
- STURDY DESIGN

Among the range of nozzles for fuel dispensing, PIUSI A60/A80/A120/A140 consist of a range of automatic devices for flow rates up to 140 l/min fitted with an inner device that automatically stops the fluid dispensing when the tank is full. These nozzles also include a swivel connector.

### PERFORMANCE

UP TO <b>140 L/MIN</b>	<b>1" BSP</b>
FLOW RATE	INLET
<b>A60</b> <b>20/24MM</b>	<b>A80/A120/A140</b> <b>29MM</b>
SPOUT	SPOUT



### PACKAGING

CODE		WEIGHT		PACKAGING			BOXES/EUROPALLET	
WITHOUT SWIVEL	WITH SWIVEL	KG	LBS	MM	INCH	PCS/BOX		
<b>A60</b>								
-	FOO603060	1,25	2,76	36OX36OX280	14X14X11	1	-	-
-	FOO602020	1,20	2,65	36OX36OX280	14X14X11	1	-	-
-	FOO613A00	1,30	2,87	36OX36OX280	14X14X11	1	-	-
<b>A80</b>								
-	FOO604030	1,93	4,25	36OX36OX280	14X14X11	1	-	-
<b>A120</b>								
-	FOO610020	1,93	4,25	36OX36OX280	14X14X11	1	-	-
-	FOO614A00	1,65	3,64	36OX36OX280	14X14X11	1	-	-
-	FOO610B00	1,93	4,25	36OX36OX280	14X14X11	1	-	-
<b>A140</b>								
-	FOO610200	2,00	4,41	46OX20OX80	181X78X31	1	-	-
<b>A70</b>								
-	FOO603B00	1,25	2,76	36OX36OX280	14X14X11	1	-	-



FILTRATION



TANK MONITORING



HOSE REEL



ACCESSORIES



MERCHANDISE

**PIUSI**

INDEX



ANY BIODIESEL



AIR



ANTIFREEZE



AdBlue®



BIODIESEL



DIESEL



FOOD



GASOLINE



GREASE



KEROSENE



OIL



WATER



WINDSCREEN

**CHART**

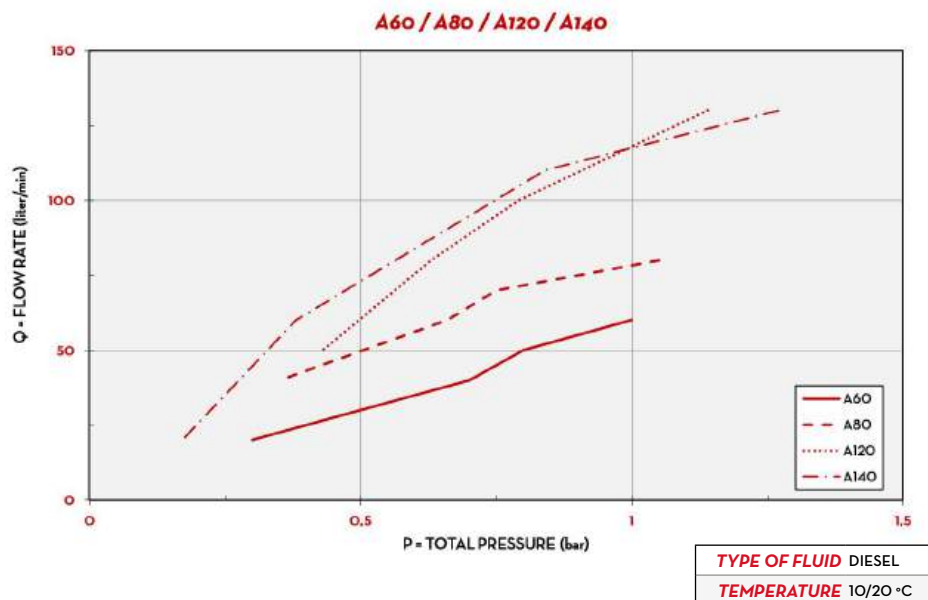

**IN THE BOX**

- A60/A80/A120/A140 NOZZLE
- INSTRUCTION MANUAL

**DETAILS**



**MATERIALS**

- BODY: ALUMINIUM
- SEAL: VITON

**TECHNICAL DATA**

CODE		DESCRIPTION	FLUIDS TYPE	FLOW RATE		INLET		SPOUT
WITHOUT SWIVEL	WITH SWIVEL			L/MIN	GPM	WITHOUT SWIVEL BSP	WITH SWIVEL BSP	EXT. Ø MM
<b>A60</b>								
-	FOO603060	AUTOMATIC NOZZLE. A60 W/SWIVEL 3/4" BSP	D G	60	16	F3/4"	F1"	24
-	FOO602020	AUTO. NOZZLE A60 W/SWIVEL 3/4" UNLEADED	D G	60	16	F3/4"	F1"	20
-	FOO613A00	AUTO. NOZZLE A60 EN 13012 W/SWIVEL 3/4"	D	70	19	F3/4"	F1"	24
<b>A80</b>								
-	FOO604030	AUTOMATIC NOZZLE A80 W/SWIVEL 1" BSP	D G	90	24	-	F1"	29
<b>A120</b>								
-	FOO610020	AUTOMATIC NOZZLE. A120 W/SWIVEL 1" BSP	D G	120	32	-	F1"	29
-	FOO614A00	AUTO NOZZLE A120 EN 13012 W/SWIVEL 1"	D	120	32	-	F1"	29
-	FOO610B00	AUTOMATIC NOZZLE A120 W/SWIV. 1" BSP B100	B D	120	32	-	F1"	29
<b>A140</b>								
-	FOO610200	AUTOMATIC NOZZLE. A140 W/SWIVEL 1" BSP	D	140	37	-	F1"	29
<b>A70</b>								
-	FOO603B00	AUTOMATIC NOZZLE A70 1" BSP B100	B D	70	19	-	F1"	24



FUEL MANAGEMENT SYSTEMS



DISPENSERS



KITS



PUMPS



METERS



NOZZLES

# A280

## FEATURES

- AUTOMATIC
- READY TO USE
- HEAVY DUTY CONDITIONS
- STURDY STRUCTURE

The PIUSI A280 is the biggest nozzle among the PIUSI range of automatic fuel nozzles with its flow rate up to 280 l/min and spout OD 38,5 mm. Fully automatic thanks to the structural device that stops dispensing when the tank is full; it comes with a built-in swivel to guarantee maximum versatility.

### PERFORMANCE

UP TO

**280 L/MIN**

FLOW RATE

**1" 1/2 BSP**

INLET

**38,5MM**

OD SPOUT

A280



A280



### PACKAGING

CODE	WEIGHT		PACKAGING			N. BOXES / EUROPALET	
	KG	LBS	MM	INCH	PCS/BOX	✕	
F13249000	3,30	7,28	-	-	1	-	-



FILTRATION



TANK MONITORING



HOSE REEL



ACCESSORIES



MERCHANDISE

# PIUSI

INDEX

BIS

ANY BIODIESEL

A

AIR

A

ANTIFREEZE

Ad

AdBlue®

B

BIODIESEL

D

DIESEL

F

FOOD

G

GASOLINE

G

GREASE

K

KEROSENE

O

OIL

W

WATER

W

WINDSCREEN

## CHART

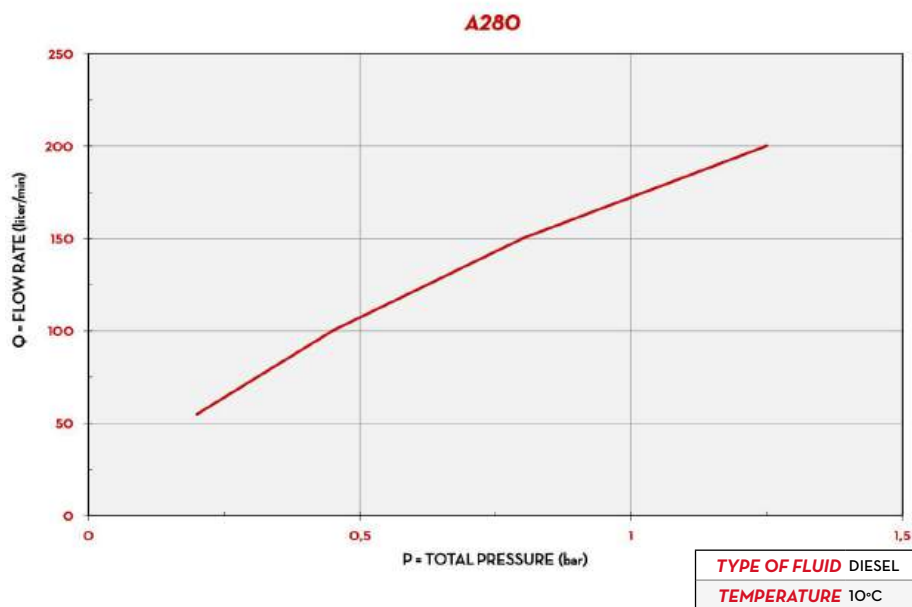

## IN THE BOX

- A280 NOZZLE
- SWIVEL 1" 1/2 BSP

## DETAILS



AUTOMATIC STOP



1" SWIVEL

## MATERIALS

- BODY: ALUMINIUM
- SEAL: VITON

## TECHNICAL DATA

CODE	DESCRIPTION	FLUIDS TYPE	FLOW RATE		INLET		SPOUT
			L/MIN	GPM	WITHOUT SWIVEL BSP	WITH SWIVEL BSP	EXT. Ø MM
F13249000	AUTOMATIC NOZZLE A280 1" 1/2 BSP	D	280	74	-	1 1/2"	38,5



FUEL MANAGEMENT SYSTEMS



DISPENSERS



KITS



PUMPS



METERS



NOZZLES

# SELF 2000 / SELF 3000

## FEATURES

- MANUAL
- VERSATILE
- HIGH EFFICIENCY
- LEVER PROTECTION

The PIUSI SELF 2000 / SELF 3000 manual nozzles perform the maximum efficiency thanks to the low-flow resistance and the wide range of applications including transfer systems run by gravity. They are supplied with removable lever protection and connectors.



SELF 2000 DIESEL



SELF 3000 DIESEL/GASOLINE



KUNSTSTOFF-ZAPFVENTIL WASSER/DIESEL

### PERFORMANCE

UP TO

150 L/MIN

FLOW RATE

20/25MM

OD SPOUT

SELF 2000 / SELF 3000



### PACKAGING

CODE	WEIGHT		PACKAGING			N. BOXES / EUROPALLET	
	KG	LBS	MM	INCH	PCS/BOX	✈	🚚
00063900A	0,7	1,5	400X250X200	16X11X7,8	1		
00064900A	0,7	1,5	400X250X200	16X11X7,8	1		
00064902A	0,7	1,5	400X250X200	16X11X7,8	1		
00065001A	0,7	1,5	400X250X200	16X11X7,8	1		
00065600A	0,7	1,5	400X250X200	16X11X7,8	1		
FO0641120	0,7	1,5	400X250X200	16X11X7,8	1		
FO0641130	0,7	1,5	400X250X200	16X11X7,8	1		
FO065000A	0,7	1,5	400X250X200	16X11X7,8	1		
FO0650020	0,7	1,5	400X250X200	16X11X7,8	1		
FO063000A	0,3	0,7	-	-	1		
FO0641B00	0,7	1,5	400X250X200	16X11X7,8	1		



FILTRATION



TANK MONITORING



HOSE REEL



ACCESSORIES



MERCHANDISE

**PIUSI**

INDEX



ANY BIODIESEL



AIR



ANTIFREEZE



AdBlue®



BIODIESEL



DIESEL



FOOD



GASOLINE



GREASE



KEROSENE



OIL



WATER



WINDSCREEN

## CHART

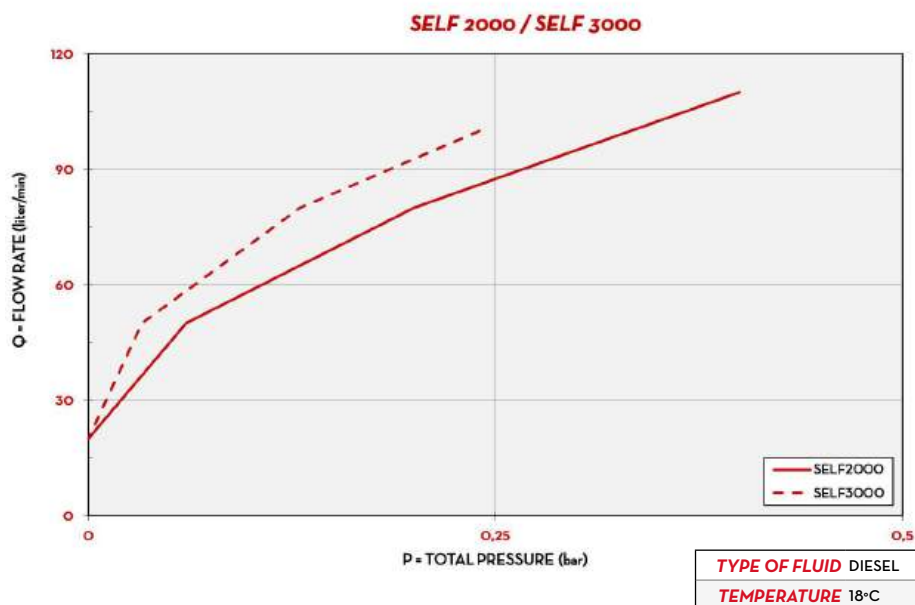

## IN THE BOX

- SELF 2000/ SELF 3000 NOZZLE

## DETAILS



LEVER PROTECTION

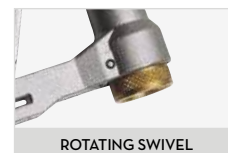

ROTATING SWIVEL

## MATERIALS

### SELF 2000 & SELF 3000

- BODY: ALUMINIUM
- SEAL: NBR70SH

### PLASTIC NOZZLE

- BODY: PP+FV
- SEAL: NBR



## TECHNICAL DATA

CODE	DESCRIPTION	FLUIDS TYPE	FLOW RATE		INLET		SPOUT
			L/MIN	GPM	SWIVEL (THREADS)	Ø BSP	EXT. Ø MM
00063900A	SELF 2000 1" BSP UNLEADED	D G O	120	32	INTERNAL	1" BSP	20
00064900A	SELF 2000 3/4" BSP	D O	120	32	INTERNAL	3/4" BSP	25
00064902A	SELF 2000 3/4" BSP UNLEADED	D G O	120	32	INTERNAL	3/4" BSP	20
00065001A	SELF 3000 1" BSP UNLEADED	D O G	150	40	INTERNAL	1" BSP	20
00065600A	SELF 2000 1" BSP SPOUT 25 MM	D O	120	32	INTERNAL	1" BSP	25
FO0641120	SELF 2000 W/HOSE TAIL D.20 SPOUT 25 MM	D O	120	32	INTERNAL	3/4" BSP	25
FO0641130	SELF 2000 1" BSP	D O	120	32	INTERNAL	1" BSP	25
FO065000A	SELF 3000 1" BSP LEADED SPOUT	D O	150	40	INTERNAL	1" BSP	25
FO0650020	SELF 3000 1" BSP LEADED SPOUT S/P	D G O W	150	40	INTERNAL	1" BSP	25
FO063000A	PLASTIC NOZZLE BLACK W/SWIVEL 1" BSP	D O W	80	21	INTERNAL	1" BSP	34
FO0641B00	SELF 2000 1" BSP B100	B100	120	32	INTERNAL	1" BSP	20



# NOZZLES ACCESSORIES

## AUTOMATIC NOZZLES

A60 / A80 / A120 / A140	CODE	DESCRIPTION	
	FOO623100	SWIVEL 34.1 M W/FILTER	 FOO623100
	FOO62500A	SWIVEL 3/4IN X 20MMs	



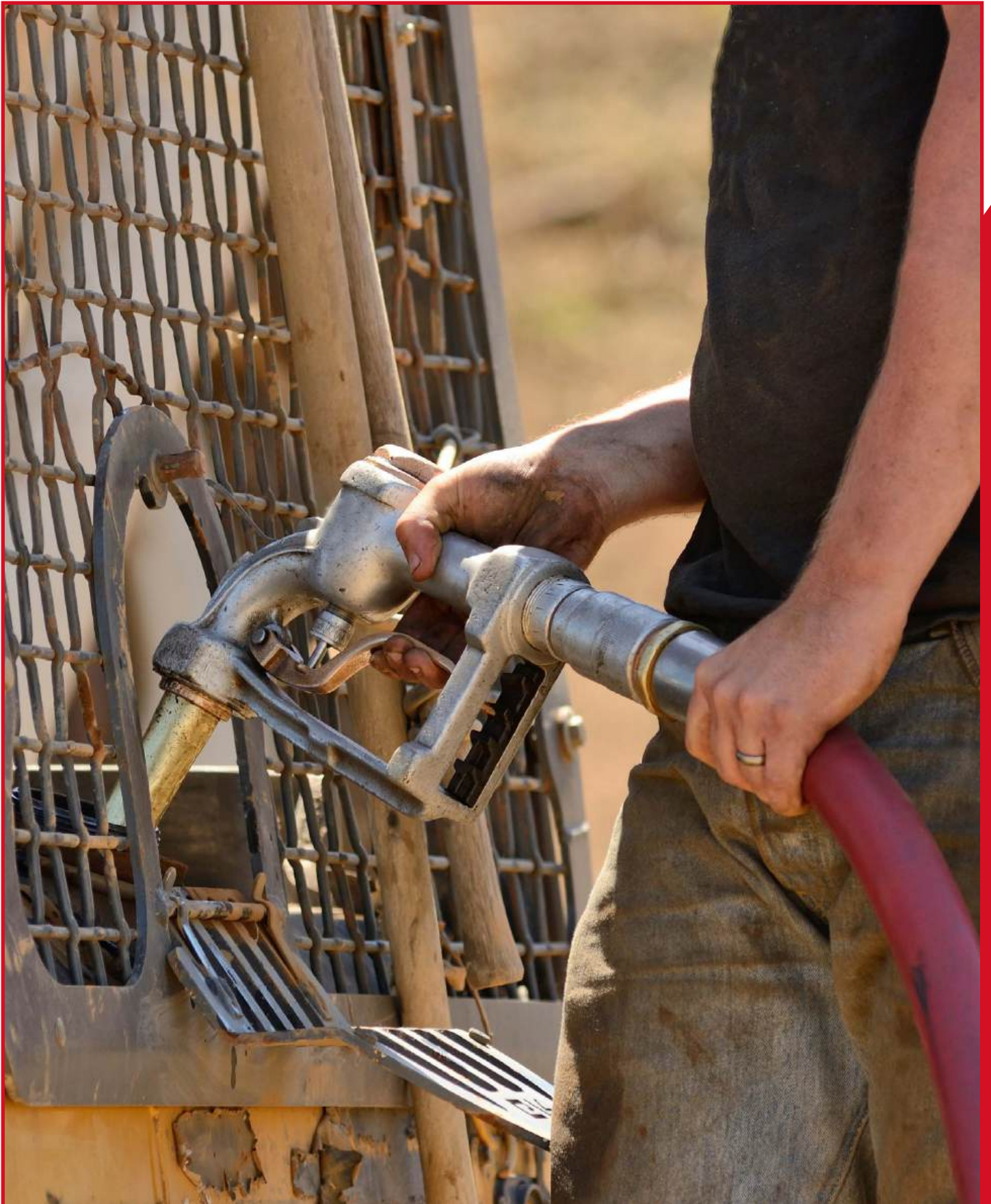

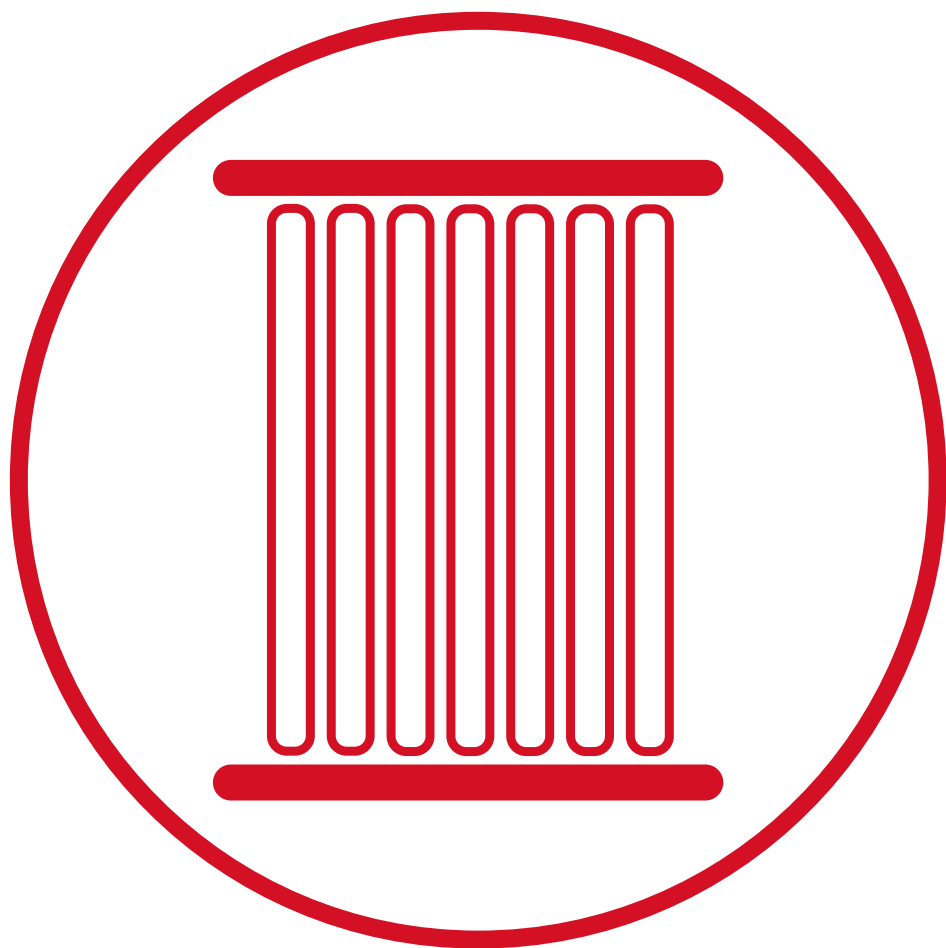

# **FILTRATION**





FUEL MANAGEMENT SYSTEMS



DISPENSERS



KITS



PUMPS



METERS



NOZZLES

# FILTROLL

## FEATURES

- DOUBLE-STAGE FILTRATION
- SPIRAL TUBE
- EASY TO HANDLE
- LARGE-DIAMETER WHEELS

The PIUSI FILTROLL is an innovative portable unit that provides a complete double filtering capacity of any kind of tank while absorbing water and impurities. The built-in sturdy trolley allows the operator to easily handle this device in any condition. It is equipped with suction pipe and integrated bottom valve.

### PERFORMANCE

UP TO <b>56 L/MIN</b> FLOW RATE	<b>AC/DC</b> VOLTAGE POWER
<b>30μ</b> WATER ABSORPTION FILTERING	<b>5μ</b> IMPURITIES FILTERING



FILTROLL

### PACKAGING

CODE	WEIGHT		PACKAGING		
	KG	LBS	MM	INCH	PCS/BOX
FO0506000	35	77,2	790X590X590	31,1X23,2X23,2	1
FO050606A	40	88,2	790X590X590	31,1X23,2X23,2	1



FILTRATION



TANK MONITORING



HOSE REEL



ACCESSORIES



MERCHANDISE

# PIUSI

INDEX

B

ANY BIODIESEL

A

AIR

A

ANTIFREEZE

Ad

AdBlue®

B

BIODIESEL

D

DIESEL

F

FOOD

G

GASOLINE

G

GREASE

K

KEROSENE

O

OIL

W

WATER

W

WINDSCREEN

## CHART

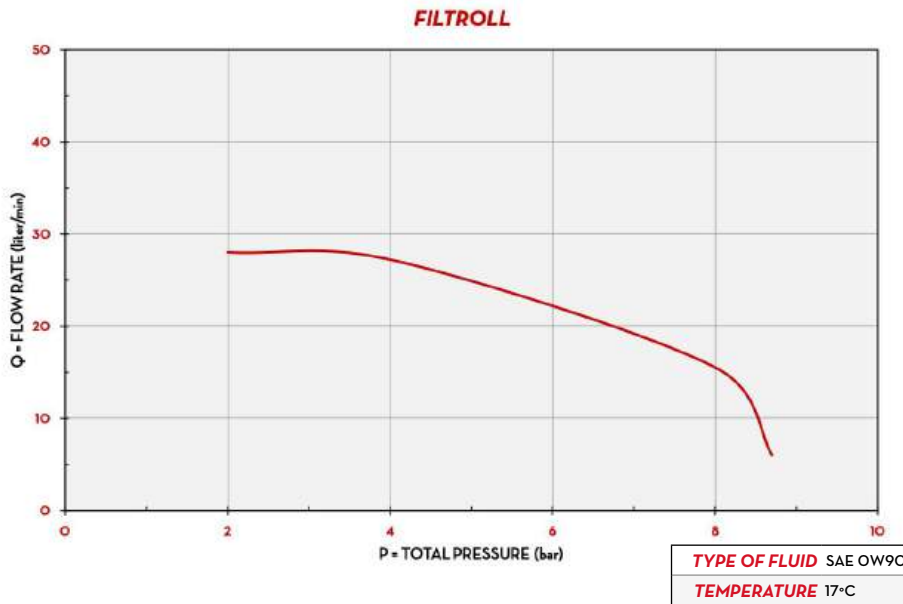

## IN THE BOX

- FILTROLL UNIT
- SUCTION HOSE
- DELIVERY HOSE
- NOZZLE
- INSTRUCTION MANUAL

## DETAILS



TWO-STEP FILTRATION



WATER/IMPURITIES FILTERS

## DIMENSIONS

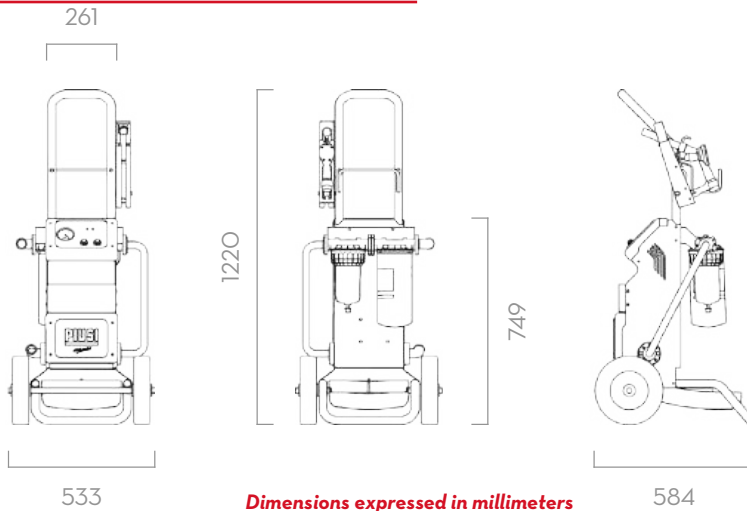

## MATERIALS

- BODY: CAST IRON
- ROTOR: SINTERED STEEL
- VANES: TECHNOPOLYMER
- SHAFT: STEEL
- FILTER: ABSORBENT FILTERING PAPER

## TECHNICAL DATA

CODE	DESCRIPTION	FLUIDS TYPE	FLOW RATE		VOLTAGE			PUMP		HOSE LENGTH	
			L/MIN	GPM	AC V./HZ DC VOLT	POWER WATT	AMP. MAX.	TYPE	DELIVERY M/FT.	SUCTION M/FT.	
FO0506000	FILTROLL DIESEL	D	56	14,8	230/50-60	350/600	3/6	PANTH. 56	4 / 13,1	3 / 9,8	
FO050606A	FILTROLL 12V DIESEL	D	56	14,8	12	300	35	PANTH. DC	4 / 13,1	4 / 13,1	

### FILTER CARTRIDGE

CODE	DESCRIPTION	MICRO	EFFICIENCY
		μ m	
FO061102A	WATER CAPTOR CART. 150 L/MIN	30	200
FO0611030	CLEAR CAPTOR CARTRIDGE	5	2

### FILTER HEAD

F1693400A	FILTER HEAD 70/100LT W/MANOM	-	-
F15744000	CLEAR CAPTOR FILTER HEAD	-	-

AVAILABLE IN VERSION 230V/60HZ, 120V/60HZ



FUEL MANAGEMENT SYSTEMS



DISPENSERS



KITS



PUMPS



METERS



NOZZLES

# WATER CAPTOR

## FEATURES

- REPLACEABLE CARTRIDGE
- HIGH EFFICIENCY
- SMALL SIZE

The PIUSI WATER CAPTOR is a filter that absorbs any residual water particles that may be present in the fluid. The innovative cartridge needs to be replaced when filtering capacity is reduced due to the amount of water particles already absorbed. Available both for 70 or 150 l/min flow rates, these filters are also available with 1" inch fitting.

### PERFORMANCE

UP TO

**150 L/MIN**

FLOW RATE

**3,5 BAR**

MAX

OPERATING PRESSURE

**200β/30μ**

FILTERING CAPACITY



WATER CAPTOR 150 L/MIN



### PACKAGING

CODE	WEIGHT	PACKAGING		
	KG	DIMENSIONS MM	CARTRIDGE PSC / BOX	FILTER HEAD PCS/BOX
<b>WATER CAPTOR</b>				
FO0611A0A	2,4	390X285X140	2	1
FO0611A1A	2,3	390X285X140	1	1
<b>WATER CAPTOR CARTRIDGE</b>				
FO0611O1B	9,8	420X320X250	12	-
FO0611O2A	9,7	350X350X360	6	-
<b>WATER CAPTOR FILTER HEAD</b>				
F14640000	-	357X357X275	-	1
F15743000	0,9	200X120X240	-	1



FILTRATION



TANK MONITORING



HOSE REEL



ACCESSORIES



MERCHANDISE

PIUSI

INDEX

B

ANY BIODIESEL

A

AIR

A

ANTIFREEZE

Ad

AdBlue®

B

BIODIESEL

D

DIESEL

F

FOOD

G

GASOLINE

G

GREASE

K

KEROSENE

O

OIL

W

WATER

W

WINDSCREEN

## PRODUCTS



150 L/MIN WATER CAPTOR  
WITH WATER ABSORPTION



70 L/MIN WATER CAPTOR  
WITH WATER ABSORPTION

## IN THE BOX

- FILTER HEAD
- WATER CAPTOR CARTRIDGE

## DETAILS



FILTER HEAD



WATER CAPTOR CARTRIDGE

## DIMENSIONS

CODE	A (MM)	B (MM)	C (MM)	D (MM)	F
FOO611A0A	-	100	280	95	-
FOO611A1A	-	171	340	120	-
FOO611O1B	220	-	-	95	1"-12 UNF
FOO611O2A	275	-	-	120	1 1/2-16 UNF
F14640000	-	100	-	-	1"-12 UNF
F15743000	-	171	-	-	1 1/2-16 UNF 1 1/4 BSP

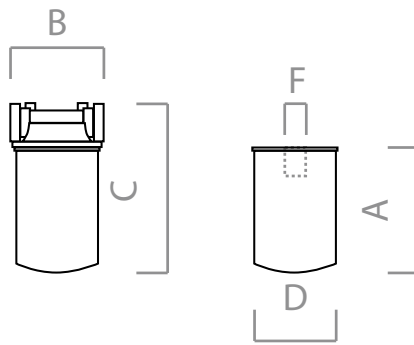

Dimensions expressed in millimeters

## MATERIALS

- FILTER: ABSORBENT FILTERING PAPER

## TECHNICAL DATA

CODE	DESCRIPTION	FLUIDS TYPE	FLOW RATE		INLET / OUTLET BSP	WATER ABSORBING	EFFICIENCY β	MICRO μm	PRESSURE BAR
			L/MIN	GPM					
<b>WATER CAPTOR</b>									
		D G							
FOO611A0A	WATER CAPTOR FILTER 70L/MIN - 2 CARTD IT	D G	70	18,5	1"	YES	200	30	3,5
FOO611A1A	WATER CAPTOR FILTER 150 L/MIN 1 CART IT	D G	150	39,6	1"	YES	200	30	3,5
<b>WATER CAPTOR CARTRIDGE</b>									
FOO611O1B	WATER CAPTOR CARTD. 70 L/MIN (12PCS) IT	D G	70	18,5	-	YES	200	30	3,5
FOO611O2A	WATER CAPTOR CART. 150 L/MIN (6PCS) IT	D G	150	39,6	-	YES	200	30	3,5
<b>WATER CAPTOR FILTER HEAD</b>									
F14640000	FILTER HEAD UNF 70 L/MIN	D G	-	-	1"	NO	-	-	-
F15743000	FILTER HEAD 70/10OLT	D G	-	-	1"	NO	-	-	-



FUEL MANAGEMENT SYSTEMS



DISPENSERS



KITS



PUMPS



METERS



NOZZLES

# CLEAR CAPTOR

## FEATURES

- REPLACEABLE CARTRIDGE
- HIGH EFFICIENCY
- SMALL SIZE

The PIUSI CLEAR CAPTOR is a range of cartridge filters that can be applied both on suction or delivery flow directions. They are equipped with a high-performance cartridge and a plastic container to collect all eventual impurities or water particles that may be present in the fluid. Thanks to the valve at the bottom of the container, it is possible to remove contaminations quickly and safely to ensure the maximum possible filter life.

### PERFORMANCE

UP TO

**100 L/MIN**

FLOW RATE

**5 BAR**

MAX

OPERATING PRESSURE

**2β/5μ**

FILTERING CAPACITY



### PACKAGING

CODE	WEIGHT	PACKAGING		
	KG	DIMENSIONS MM	CARTRIDGE PSC / BOX	FILTER HEAD PCS/BOX
<b>CLEAR CAPTOR</b>				
FOO611B00	2,3	390X285X140	2	1
FOO611B10	2,0	390X285X140	2	1
FOO611B60	2,3	390X285X140	1	1
<b>CLEAR CAPTOR CARTRIDGE</b>				
FOO611O30	1,9	190X190X240	6	-
FOO611O40	1,2	190X190X240	6	-
FOO611O60	0,2	190X190X240	1	1
<b>CLEAR CAPTOR FILTER HEAD</b>				
F15744000	1,0	200X120X240	-	1





FILTRATION



TANK MONITORING



HOSE REEL



ACCESSORIES



MERCHANDISE

# PIUSI

INDEX

B

ANY BIODIESEL

A

AIR

A

ANTIFREEZE

Ad

AdBlue®

B

BIODIESEL

D

DIESEL

F

FOOD

G

GASOLINE

G

GREASE

K

KEROSENE

O

OIL

W

WATER

W

WINDSCREEN

## PRODUCTS



## IN THE BOX

- FILTER CARTRIDGE
- FILTER HEAD
- ADDITIONAL CARTRIDGE (WHERE PROVIDED)

## DETAILS



## DIMENSIONS

CODICE	A (MM)	B (MM)	C (MM)	D (MM)	F
FOO611B00	-	171	270	-	-
FOO611B10	-	171	270	-	-
FOO611B60	-	171	270	-	-
FOO611O30	110	-	-	75	1" BSP M
FOO611O40	155	-	-	75	1" BSP M
FOO611O60	110	-	-	75	1" BSP M
F15744000	-	171	-	-	1" BSP F

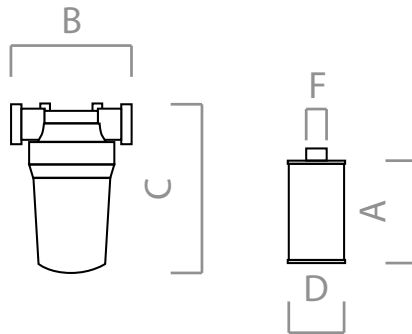

## MATERIALS

- FILTER: ABSORBENT FILTERING PAPER (NO STRAINER VERSION)

## TECHNICAL DATA

CODE	DESCRIPTION	FLUIDS TYPE	FLOW RATE		INLET / OUTLET BSP	WATER ABSORBING	EFFICIENCY β	MICRO μ m	PRESSURE BAR
			L/MIN	GPM					
<b>CLEAR CAPTOR</b>									
FOO611B00	CLEAR CAPTOR FILTER	B D	100	26,4	1"	NO	2	5	5
FOO611B10	CLEAR CAPTOR WATER FILTER	B D	70	18,5	1"	YES	200	30	5
FOO611B60	CLEAR CAPTOR STRAINER	B D	100	26,4	1"	NO	2	120	5
<b>CLEAR CAPTOR CARTRIDGE</b>									
FOO611O30	CLEAR CAPTOR CARTRIDGE	B D	100	26,4	-	NO	2	5	-
FOO611O40	CLEAR CAPTOR WATER FILTER CARTRIDGE	B D	70	18,5	-	YES	200	30	-
FOO611O60	CLEAR CAPTOR STRAINER CARTRIDGE	B D	100	26,4	-	NO	2	120	-
<b>CLEAR CAPTOR FILTER HEAD</b>									
F15744000	FILTER HEAD CLEAR CAPTOR	B D	-	-	1"	NO	-	-	-



FUEL MANAGEMENT SYSTEMS



DISPENSERS



KITS



PUMPS



METERS



NOZZLES

# FUEL & BIOFUEL

## FEATURES

- REPLACEABLE CARTRIDGE
- HIGH EFFICIENCY
- SMALL SIZE

Among its range of filters, PIUSI has developed the FUEL&BIOFUEL FILTER: cartridge and water absorbing filters that prevent fluid contamination thanks to their improved filtration capacity up to 30µ.

### PERFORMANCE

UP TO <b>100 L/MIN</b>	<b>3,5 BAR</b> MAX
FLOW RATE	OPERATING PRESSURE
<b>FILTERING CAPACITY</b> <b>10µ/200β</b>	<b>FILTERING CAPACITY</b> <b>5-10µ/2β</b>
BIOFUEL	FUEL



BIO-FUEL FILTER



OIL AND FUEL FILTER



LINE FILTER 1-1



### PACKAGING

CODE	WEIGHT	DIMENSIONS MM	PACKAGING	
	KG		CARTRIDGE PSC / BOX	FILTER HEAD PCS/BOX
<b>FILTRI BIOFUEL</b>				
FO0611COO	2	390X285X140	2	1
FO0611C10	1,9	390X285X140	1	1
<b>CARTUCCE PER FILTRI BIOFUEL</b>				
F14861000	0,9	-	1	-
F1486200A	1,5	280X160X140	1	-
<b>FILTRI FUEL</b>				
FO777200A	1	200X120X140	1	1
FO914900B	2,6	390X285X140	1	1
<b>CARTUCCE PER FILTRI FUEL</b>				
FO935900A	1,2	-	1	-
FO0611000	0,5	-	1	-
F16483010	9,2	500X300X200	15	-
<b>TESTATE FILTRI</b>				
F14528000	0,3	360X360X280	-	1
F14640000	0,3	-	-	1
F15743000	0,8	200X120X140	-	1
<b>INLINE FILTER</b>				
FO8950000	0,6	-	-	-



FILTRATION



TANK MONITORING



HOSE REEL



ACCESSORIES



MERCHANDISE

# PIUSI

INDEX



ANY BIODIESEL



AIR



ANTIFREEZE



AdBlue®



BIODIESEL



DIESEL



FOOD



GASOLINE



GREASE



KEROSENE



OIL



WATER



WINDSCREEN

## DIMENSIONS

A B C D F  
(MM) (MM) (MM) (MM)

### FILTER FOR BIOFUEL

FO0611C00	-	100	275	95	-
FO0611C10	-	171	340	130	-
F14861000	220	-	-	95	1" - 12 UNF
F1486200A	275	-	-	130	1" 1/2 - 16 UNF
F14640000	-	100	-	-	1" - 12 UNF
F15743000	-	171	-	-	1" 1/2 - 16 UNF 1" 1/4 BSP

### FILTER FOR FUEL AND OIL

FO777200A	-	100	160	98	-
FO914900B	-	171	236	132	-
FO0611000	145	-	-	98	3/4" BSP
FO935900A	180	-	-	132	1" 1/4 BSP
F14528000	-	100	-	-	3/4" BSP
F15743000	-	171	-	-	1" 1/2 - 16 UNF 1" 1/4 BSP
F16483010	139	-	-	93	3/4" BSP

### LINE FILTER

FO8950000	-	-	-	-	-
-----------	---	---	---	---	---

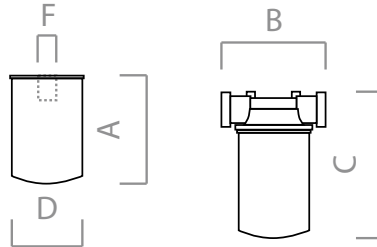

### BIO-FUEL / OIL AND FUEL FILTERS

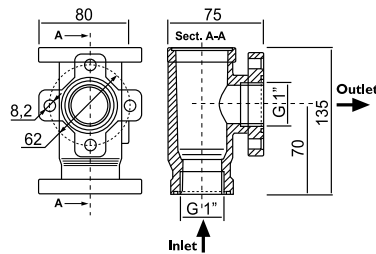

### LINE FILTER 1-1

Dimensions expressed in millimeters

## IN THE BOX

- FILTER CARTRIDGE
- METALLIC HEAD (WHERE PROVIDED)
- ADDITIONAL CARTRIDGE

## DETAILS



FILTER HEAD



REPLACEABLE CARTRIDGE



INLINE FILTER



INLINE FILTER

## MATERIALS

- FILTER: ABSORBENT FILTERING PAPER (NO INLINE FILTER)

## TECHNICAL DATA

CODE	DESCRIPTION	FLUIDS TYPE	FLOW RATE		INLET / OUTLET BSP	WATER ABSORBING	EFFICIENCY β	MICRO μ m	PRESSURE BAR
			L/MIN	GPM					
<b>FILTRI BIOFUEL</b>									
FO0611C00	BIO-FUEL FILTER 70 L/MIN 1"X1"	B G	70	18,5	1"	YES	200	10	3,5
FO0611C10	BIO-FUEL FILTER 100 L/MIN 1"X1"	B G	100	26,4	1"	YES	200	10	3,5
<b>CARTUCCE PER FILTRI BIOFUEL</b>									
F14861000	CARTRIDGE 70 L/MIN BIO-FUEL	B G	70	19,5	1" - 12 UNF	YES	200	10	FUEL
F1486200A	CARTRIDGE BIODIESEL WAT. SEP 100 L/M	B D G	150		1 1/1" - 16 UNF	YES	200	10	3,4
<b>FILTRI FUEL</b>									
FO777200A	60 L/MIN FILTER WITH HEAD	B D G O	60	15,9	1"	NO	2	10	12
FO914900B	100 L/MIN FILTER WITH HEAD	B D G O	100	26,4	1"	NO	2	10	12
<b>CARTUCCE PER FILTRI FUEL</b>									
FO935900A	CARTRIDGE 100 L/MIN	B D G O	100	26,4	-	NO	2	10	12
FO0611000	FUEL&OIL FILTER CARTRIGE 10 MICRON 3/4	D O	60	16	3/4 BSP	YES	2	10	12
F16483010	CARTUCCIA 10 MIC FILTRO 3/4" IN PIUSI_BOX	D O	60	15,9	3/4" BSP	NO	2	10	12
<b>TESTATE FILTRI</b>									
F14528000	FILTER HEAD 3/4 BSP 60 L/MIN	-	-	-	1"	-	-	-	-
F14640000	FILTER HEAD 1"INX1"IN UNF	-	-	-	1"	-	-	-	-
F15743000	FILTER HEAD 70/100LT	-	-	-	1"	-	-	-	-
<b>INLINE FILTER</b>									
FO8950000	LINE FILTER	-	-	-	1"	-	-	350	-



FUEL MANAGEMENT SYSTEMS



DISPENSERS



KITS



PUMPS



METERS



NOZZLES

# FOOT VALVE

## FEATURES

- HEAVY DUTY
- STURDY STRUCTURE
- LOW PRESSURE DROP
- ANTI-SHOCK MATERIALS

The FOOT VALVE designed and engineered by PIUSI is a new concept of valve for fuel suction hoses on machinery. It is fitted with a mesh filter for diesel fuel residues, anti-shock materials to avoid damage caused by dropping and, thus, a low dropping pressure. The quick locking/unlocking and the clear indications of opening and closing complete its main features.

### PERFORMANCE

**1200μ**

FILTERING CAPACITY

**1"-3/4"**

BSP

INLET



FOOT VALVE WITH FILTER



FOOT VALVE - F1239904C



### PACKAGING

CODE	WEIGHT		PACKAGING		
	KG	LBS	DIMENSIONS MM	INCH	PCS/BOX
F00609000	2,5	5,3	180X180X170	7,1X7,1X6,7	10
F00612000	0,2	0,44	-	-	1
F21476000	0,35	0,77	-	-	1
F15749000	1,35	3	215X147X116	8,5X5,8X4,6	12
F07978000	6,7	14,8	180X180X170	7,1X7,1X6,7	25
F08153000	0,15	0,33	-	-	1
F07746000	0,2	0,44	-	-	1
F1239900C	0,5	1,1	360X190X290	14X7,4X11,4	1
F1239904C	0,5	1,1	360X190X260	14X7,4X10,2	1
F09170000	6,5	14,3	180X180X170	7,1X7,1X6,7	25



FILTRATION



TANK MONITORING



HOSE REEL



ACCESSORIES



MERCHANDISE

# PIUSI

INDEX

B

ANY BIODIESEL

A

AIR

A

ANTIFREEZE

Ad

AdBlue®

B

BIODIESEL

D

DIESEL

F

FOOD

G

GASOLINE

G

GREASE

K

KEROSENE

O

OIL

W

WATER

W

WINDSCREEN

**FO0609000**

Ø25



**FO0612000**

Ø19



**F21476000**

1"-1/2 BSP



**FO7979000**  
1" BSP



**FI0571000**  
3/4" BSP



**FO775700A** (20pz)  
1" x Ø20

**FO776400A** (20pz)  
1" x Ø25



**FI5749000**

1" BSP



1" BSP

**FO7978000**  
**FO9170000**  
(SAFETY VALVE)

1" BSP



1" BSP

**FO8153000**

3/4" BSP



3/4" BSP

## TECHNICAL DATA

CODE	DESCRIPTION	FLUIDS TYPE	SAFETY VALVE					MICRO
								µ m
FO0609000	FOOT VALVE CON FILTRO 1" BSP	D G O	YES	YES	-	YES	YES	1200 µ m
FO0612000	FOOT VALVE CON FILTRO 3/4" BSP	D G O	YES	YES	-	YES	YES	1200 µ m
F21476000	FOOT VALVE W/FILTER 1"-1/2 BSP	D O	-	-	YES	YES	-	1200 µ m
FI5749000	1" WITH BUILT-IN SAFETY VALVE	D G O	YES	YES	-	-	-	-
FO7978000	FOOT VALVE WO/FILTER 1" BSP	D O	-	-	YES	-	-	-
FO8153000	FOOT VALVE WO/FILTER 3/4" BSP	D O	-	-	YES	-	-	-
FO7746000	FOOT VALVE W/FILTER 1" BSP BRASS	D O	-	-	YES	YES	-	-
FI239900C	FOOT VALVE HF F 3/4 BSP	D O	-	-	YES	-	-	-
FI239904C	FOOT VALVE HF +PORTAG -X D.20,2	D O	-	-	YES	-	-	-
FO9170000	HIGH PRESSURE VALVE 1" BSP	D O	YES	-	YES	-	-	-



# **TANK MONITORING**

A large, solid red triangle is positioned in the bottom right corner of the page, pointing towards the top right. It is a simple, flat color with no text or other details inside it.



FUEL MANAGEMENT SYSTEMS



DISPENSERS



KITS



PUMPS



METERS



NOZZLES

# OCIO

## FEATURES

- LOW/HIGH LEVEL ALARMS
- FLUID MEASURES INDICATION
- BUILT-IN DISPLAY

OCIO is PIUSI's tank level indicator suitable for any kind of fluid stored in tanks up to a 4 mt depth. It gives a real time indication of the fluid quantity inside the tank. It is easy to calibrate and has two alarms that can be adjusted at a specific high and low level for high and low levels.

### PERFORMANCE

UP TO

**4MT**

HEIGHT

TANK

**± 1%**

FULL SCALE

ACCURACY

UP TO

**50 MT**

LENGTH

PROBE TUBE

UP TO

**30 CST**

VISCOSITY



OCIO



10 METERS HOSE



BRASS PROBE

### PACKAGING

CODE	WEIGHT		PACKAGING		
	KG	LBS	MM	INCH	PCS/BOX
FO075510D	2,2	4,8	300X410X100	11,8X16,1X3,9	1
FO075516O	2,2	4,8	300X410X100	11,8X16,1X3,9	1





FILTRATION



TANK MONITORING



HOSE REEL



ACCESSORIES



MERCHANDISE

# PIUSI

INDEX

IS

ANY BIODIESEL

A

AIR

A

ANTIFREEZE

Ad

AdBlue®

B

BIODIESEL

D

DIESEL

F

FOOD

G

GASOLINE

G

GREASE

K

KEROSENE

O

OIL

W

WATER

W

WINDSCREEN

### FUNCTIONING

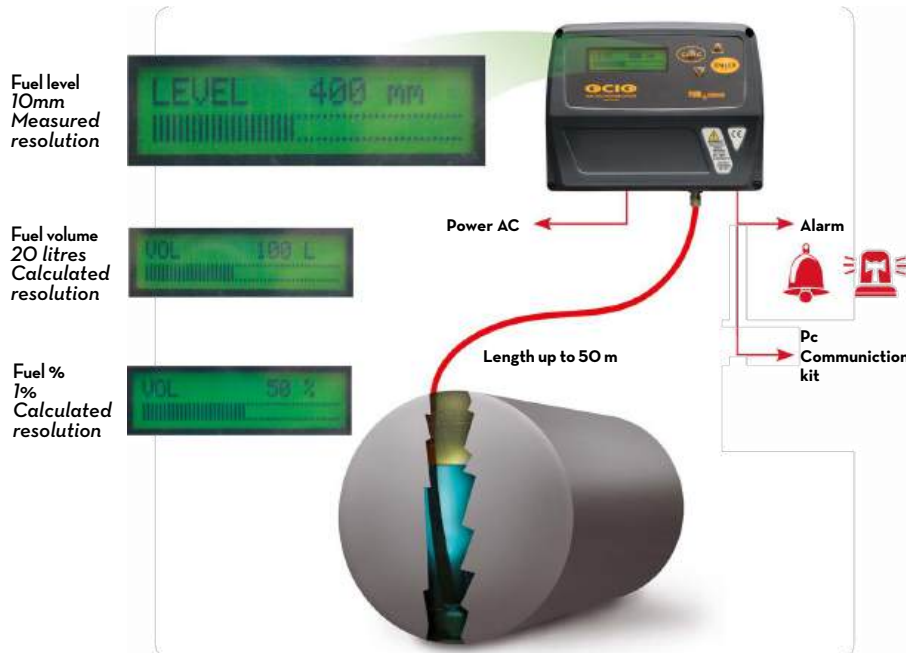

### IN THE BOX

- OCIO UNIT
- PROBE
- 10 MT TUBE
- INSTRUCTION MANUAL

### DETAILS



### DIMENSIONS

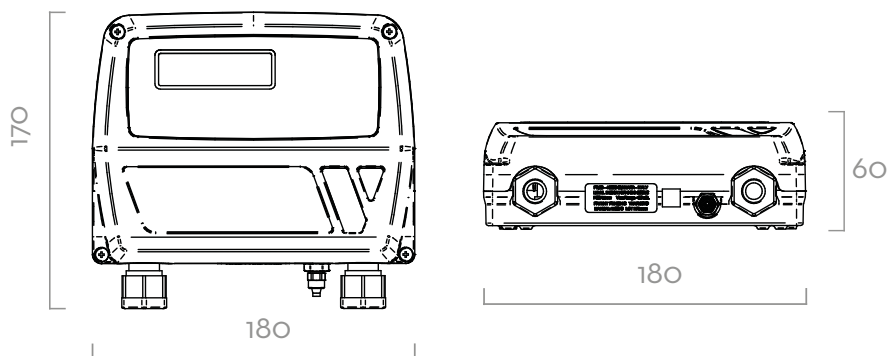

Dimensions expressed in millimeters

### MATERIALS

- PROBE: BRASS
- TUBE: RILSAN (POLYAMIDE)

### TECHNICAL DATA

CODE	DESCRIPTION	FLUIDS TYPE	VISCOSITY	VOLTAGE		RS EXIT
			cSt	AC V/HZ	POWER WATT	
FO075510D	LEVEL INDICATOR OCIO LV / RS OUTPUT	A B D O W	UP TO 30	230/50	20	AVAILABLE
FO075516O	LEVEL INDICATOR OCIO LV / 4/20 mA OUTPUT	A B D O W	UP TO 30	230/50	20	AVAILABLE



FUEL MANAGEMENT SYSTEMS



DISPENSERS



KITS



PUMPS



METERS



NOZZLES

# OCIO 2.0

## FEATURES

- LOW/HIGH LEVEL ALARMS
- FLUID QUANTITY INDICATION
- FLUID HEIGHT INDICATION
- BUILT-IN DISPLAY
- COMPATIBLE WITH SSM 2.0, MCO 2.0 AND B.SMART

With its brand-new design, OCIO 2.0 by PIUSI is the upgraded version of the tank level indicator compatible with SSM 2.0, MCO 2.0 and B.Smart systems. It requires a LAN/Wi-Fi connection to communicate with the software. It maintains all the performances of the standard OCIO. Thanks to its interchangeable probe, OCIO 2.0 is compatible with several fluids.

### PERFORMANCE

UP TO <b>4MT</b> HEIGHT TANK	$\pm 1\%$ FULL SCALE ACCURACY
UP TO <b>50 MT</b> LENGTH PROBE TUBE	UP TO <b>30 CST</b> VISCOSITY



OCIO 2.0

10 METERS HOSE

BRASS PROBE

### PACKAGING

CODE	WEIGHT		PACKAGING		
	KG	LBS	MM	INCH	PCS/BOX
FO0755260	2,2	4,8	300X410X100	11,8X16,1X3,9	1
FO0755220	2,2	4,8	300X410X100	11,8X16,1X3,9	1
FO075521A	2,2	4,8	300X410X100	11,8X16,1X3,9	1



FILTRATION



TANK MONITORING



HOSE REEL



ACCESSORIES



MERCHANDISE



INDEX



ANY BIODIESEL



AIR



ANTIFREEZE



AdBlue®



BIODIESEL



DIESEL



FOOD



GASOLINE



GREASE



KEROSENE



OIL



WATER



WINDSCREEN

### CONNECTION



### IN THE BOX

- OCIO 2.0
- PROBE
- 10 MT TUBE
- INSTRUCTION MANUAL

### DETAILS



BRASS PROBE



2 ALARMS



INTEGRATED LAN ADAPTER



SSM 2.0 SOFTWARE

### FUNCTIONING

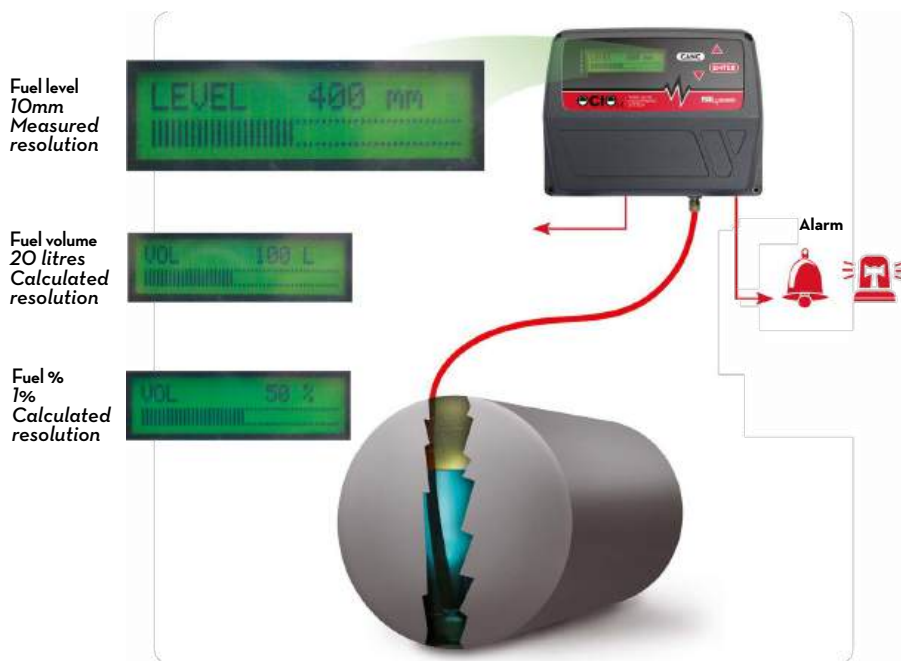

### MATERIALS

- PROBE: BRASS
- TUBE: TECHNOPYLIMER



### TECHNICAL DATA

CODE	DESCRIPTION	FLUIDS TYPE	VISCOSITY	VOLTAGE	
			cSt	AC V/ HZ	POWER WATT
FO0755260	LEVEL INDICATOR OCIO LAN 2.0	A B D O W	UP TO 30	230-50/60	20
FO0755220	LEVEL INDICATOR OCIO RS485 2.0	A B D O W	UP TO 30	230-50/60	20
FO075521A	LEVEL INDICATOR OCIO WIFI 2.0	A B D O W	UP TO 30	230-50/60	20



# TANK MONITORING ACCESSORIES

## TANK LEVEL INDICATORS

OCIO	CODE	DESCRIPTION	
	F1391300A	KIT 50 MT OCIO PIPE D.6X4	 F1391300A





# **HOSE REEL**



FUEL MANAGEMENT SYSTEMS



DISPENSERS



KITS



PUMPS



METERS



NOZZLES

# DIESEL HOSE REEL

## FEATURES

- STURDY STRUCTURE
- HAND PROTECTION
- CORROSION RESISTANCE
- REDUCED PRESSURE LOSS
- HEAVY DUTY CONDITIONS

PIUSI automatic DIESEL HOSE REELS for diesel have been designed to ensure high efficiency. The sturdy structure can guarantee the best performance also in heavy duty conditions.

### PERFORMANCE

**15 BAR**

MAX

OPERATING PRESSURE

MAX  
**20 MT**

LENGTH

HOSE BOUND



AUTOMATIC HOSE REEL WITH HOSE



HOSE DIESEL HOSE REEL FOR 12M HOSE VERSION



### PACKAGING

CODE	WEIGHT		PACKAGING			N. BOXES / EUROPALET	
	KG	LBS	MM	INCH	PCS/BOX	✈	🚚

#### WITHOUT HOSE

FO075000A	19	41,9	550X260X540	-	1	12	20
FO075001A	18	39,7	550X260X540	-	1	12	20
FO075008A	15	33,1	550X260X540	-	1	12	20
FO075025A	22,3	49,1	560X350X560	-	1	12	20
FO075018B	21	46	550X260X540	-	1	12	20

#### WITH HOSE

FO075002B	26	57,3	550X260X540	-	1	12	20
FO075003B	25	55,1	550X260X540	-	1	12	20
FO075023B	25	55,1	550X260X540	-	1	12	20
FO075004B	22	49,5	550X260X540	-	1	12	20
FO075012B	22	49,5	550X260X540	-	1	12	20
FO075009B	18	39,6	550X260X540	-	1	12	20
FO075010B	27	59,5	550X260X540	-	1	12	20
FO075019B	27	59,5	560X350X560	-	1	8	12
FO075026B	27	59,5	560X350X560	-	1	8	12





FILTRATION



TANK MONITORING



HOSE REEL



ACCESSORIES



MERCHANDISE

# PIUSI

INDEX



ANY BIODIESEL



AIR



ANTIFREEZE



AdBlue®



BIODIESEL



DIESEL



FOOD



GASOLINE



GREASE



KEROSENE



OIL



WATER



WINDSCREEN

### INSTALLATION&DIMENSIONS

Different ways to install PIUSI's hose reels: they can be easily placed wherever you need them without any problem about functionality and safety. PIUSI's products are without a doubt designed to support your work in any condition.

#### ROOF INSTALLATION

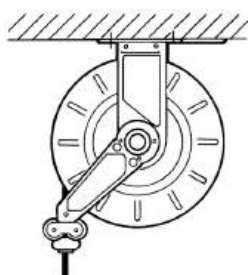

#### WALL INSTALLATION

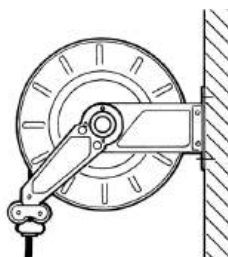

#### GROUND INSTALLATION

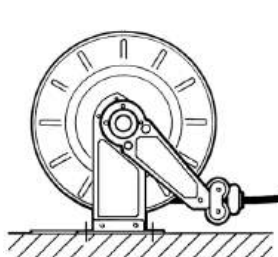

MODEL	HOSE REEL XL	HOSE REEL BIG	HOSE REEL SMALL
A	512	495	475
B	470	460	460
C	227	152	102
D	200	200	150
E	322	246	196
F	160	150	150
G	260	200	150
H	12	12	12
L	382	306	256

A	512	495	475
B	470	460	460
C	227	152	102
D	200	200	150
E	322	246	196
F	160	150	150
G	260	200	150
H	12	12	12
L	382	306	256

#### HOSE REEL FRONT / SIDE

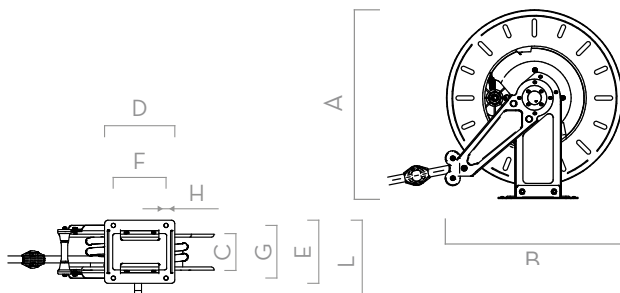

Dimensions expressed in millimeters

### IN THE BOX

- REEL
- WALL MOUNT BRACKET
- INSTRUCTION MANUAL

### DETAILS



4 ROLLS HOSE GUIDE



AUTOMATIC HOSE REELS



DIFFERENT INSTALLATIONS



STURDY DESIGN

### MATERIALS

- BODY: CAST IRON
- HUB: SYNTHETIC STEEL
- TUBE: RUBBER

### TECHNICAL DATA

CODE	DESCRIPTION	FLUIDS TYPE	HOSE	MAX OPERATING PRESSURE	PRESSURE DROP	INLET	OUTLET	HOSE MAX LENGTH BOUND	HOSE LENGTH
			BSP	BAR	TYPE	WITH SWIVEL BSP	HOSETAIL BSP	METERS	METER

#### WITHOUT HOSE

FO075000A	HOSE REEL 3/4" BIG	D	3/4"	10	0,15 @ 60 L/MIN	1" MALE	3/4"	14	-
FO075001A	HOSE REEL 1" BIG	D	1"	10	0,2 @ 80 L/MIN	1" MALE	1"	10	-
FO075008A	HOSE REEL 3/4" SMALL	D	3/4"	10	0,15 @ 60 L/MIN	1" MALE	3/4"	10	-
FO075025A	HOSE REEL 1" XL HEAVY DUTY (STEEL HUB)	D	1"	15	0,5 @ 80 L/MIN	1" FEMALE	1" MALE	15	-
FO075018B	HOSE REEL NAKED XL 15M	D	1"	10	0,2 @ 80 L/MIN	1" FEMALE	1" MALE	15	-

#### WITH HOSE

FO075002B	HOSE REEL 8X1" BIG	D	1"	10	0,6 @ 80 L/MIN	1" FEMALE	1" MALE	-	8
FO075003B	HOSE REEL 10X1" BIG	D	1"	10	0,7 @ 80 L/MIN	1" FEMALE	1" MALE	-	10
FO075023B	HOSE REEL 10X1" BIG HEAVY DUTY (STEEL HUB)	D	1"	10	0,7 @ 80 L/MIN	1" FEMALE	1" MALE	-	10
FO075004B	HOSE REEL 10X3/4" BIG	D	3/4"	10	0,7 @ 60 L/MIN	1" FEMALE	1" MALE	-	10
FO075012B	HOSE REEL 10X3/4" BIG	D	3/4"	10	0,7 @ 60 L/MIN	1" FEMALE	3/4" MALE	-	10
FO075009B	HOSE REEL 8X3/4" SMALL	D	3/4"	10	0,6 @ 60 L/MIN	1" FEMALE	1" MALE	-	8
FO075010B	HOSE REEL 14X3/4" BIG	D	3/4"	10	0,6 @ 60 L/MIN	1" FEMALE	1" MALE	-	14
FO075019B	HOSE REEL 15X1" XL	D	1"	15	1 @ 80 L/MIN	1" FEMALE	1" MALE	-	15
FO075026B	HOSE REEL 15X1" XL HEAVY DUTY (STEEL HUB)	D	1"	15	0,8 @ 80 L/MIN	1" FEMALE	1" MALE	-	15

MINIMUM RADIUS OF CURVATURE FOR 3/4 HOSE SIZES "AND 1" OF AT LEAST 130MM; ELECTRICALLY, THE HOSE MUST BE CONDUCTOR R-1 MOhm/m



# HOSE REELS ACCESSORIES

## OPEN HOSE REEL

DIESEL HOSE REEL	CODE	DESCRIPTION
	F1627900A	SMALL HOSE REEL FIXED BASE
	F1629800A	SMALL HOSE REEL ROTATING SUPPORT
	F16367000	BIG HOSE REEL ROTATING SUPPORT
	F1731600A	BIG HOSE REEL FIXED BASE
	F1731700A	DIESEL HOSE Ø25 L=1M CRIMPED 1"X1"



F1629800A  
F1731600A

F1627900A  
F1731700A

F16367000



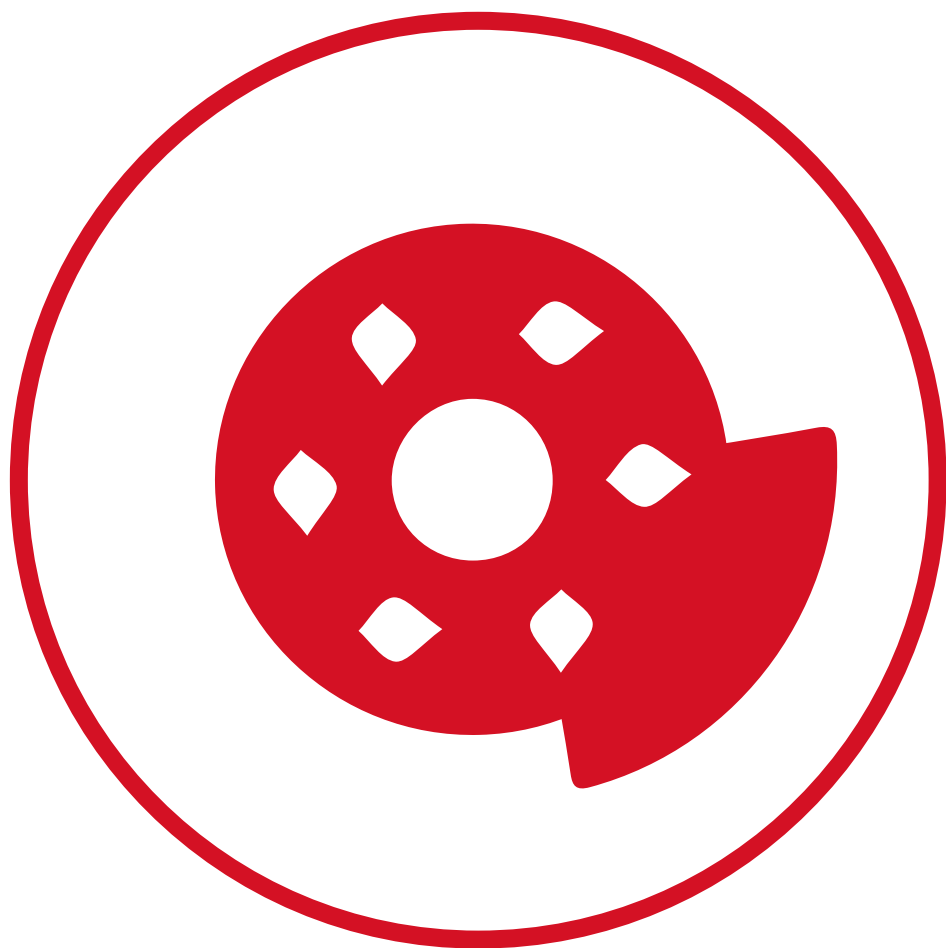

# **ACCESSORIES**

A large, solid red triangle is positioned in the bottom right corner of the page, pointing towards the top right. The rest of the page is white.



FUEL MANAGEMENT SYSTEMS



DISPENSERS



KITS



PUMPS



METERS



NOZZLES

# ACCESS 85

## FEATURES

- ACCESS CONTROL
- SUITABLE FOR ANY PUMP AND SYSTEM
- READY TO USE
- MULTI USERS
- LEVEL CONTROL INPUT

The PIUSI ACCESS 85 is an electronic control unit that allows users to control the withdrawal of fuel from a tank by several users. It is able to control: pump start and stop, user access by means of electronic key, the position of the dispenser gun with relevant go ahead. It also features a built-in emergency button to stop all operations.

### PERFORMANCE

UP TO

**85**

USERS

**AC**

CONTINUOUS DUTY

POWER



ACCESS 85



### PACKAGING

CODE	WEIGHT		PACKAGING		
	KG	LBS	MM	INCH	PCS/BOX
FO0702000	0,7	1,5	120X140X200	4,7X5,5X7,9	1



FILTRATION



TANK MONITORING



HOSE REEL



ACCESSORIES



MERCHANDISE



INDEX



ANY BIODIESEL



AIR



ANTIFREEZE



AdBlue®



BIODIESEL



DIESEL



FOOD



GASOLINE



GREASE



KEROSENE



OIL



WATER



WINDSCREEN

### FUNCTIONING



PUMP CONTROL



NOZZLE SWITCH CONTROL



TANK ALARM CONTROL



### IN THE BOX

- ACCESS 85 UNIT
- INSTRUCTION MANUAL

### DETAILS



DRIVER KEY (OPTIONAL)



EMERGENCY BUTTON

### TECHNICAL DATA

CODE	DESCRIPTION	FLUIDS TYPE	USERS	USERS KEY	VOLTAGE		
					AC V./HZ	POWER WATT	AMP. MAX.
FO0702000	ACCESS 85	<b>D</b> <b>G</b> <b>K</b> <b>O</b>	85	NO	230	3,5	6



FUEL MANAGEMENT SYSTEMS



DISPENSERS



KITS



PUMPS



METERS



NOZZLES

# CONNECTORS

## FEATURES

- STURDY STRUCTURE
- READY TO USE
- SEVERAL SOLUTIONS AVAILABLE

The range of fuel products is completed with a wide array of accessories for connecting products to allow the best performance. Starting from the 2" connectors and quick coupling.

### PERFORMANCE

2"

DRUM CONNECTOR

2"

QUICK COUPLING



2" DRUM CONNECTOR WITHOUT INTEGRATED VALVE



2" DRUM CONNECTOR WITH FLANGED AND INTEGRATED VALVE



2" DRUM CONNECTOR WITH INTEGRATED VALVE



2" QUICK COUPLING



### PACKAGING

CODE	PACKAGING			
	KG	MM	INCH	PCS/BOX
<b>2" CONNECTOR</b>				
F17163000	0,6	133X98X85		1
F17190000	0,6	133X98X85		1
F17163010	0,8	133X98X85		1
<b>2" QUICK COUPLING</b>				
RO9160000	0,9	133X98X85		1
FO893000A	0,9	133X98X85		1
<b>EXTENSIBLE PIPE</b>				
FO8934000	0,2	680X40X40		
FO8934010	3,9	830X160X100		
FO8934020	1,9	680X40X40		1





FILTRATION



TANK MONITORING



HOSE REEL



ACCESSORIES



MERCHANDISE

# PIUSI

INDEX



ANY BIODIESEL



AIR



ANTIFREEZE



AdBlue®



BIODIESEL



DIESEL



FOOD



GASOLINE



GREASE



KEROSENE



OIL



WATER



WINDSCREEN

## DIMENSIONS

### COMPLETE KIT EXTENSIBLE SUCTION PIPE (1800MM)

CODE:  
FO08934010

WEIGHT:  
3,9 KG

PACKAGING:  
820X150X100

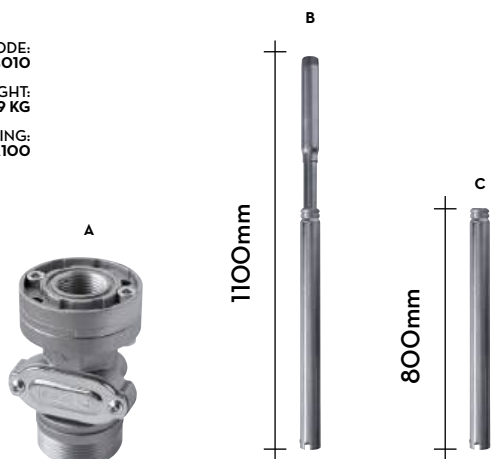

A:  
DRUM CONNECTOR  
FLANGED AND VALVE

B:  
EXTENSIBLE STEEL  
PIPE 1" BSP

C:  
STEEL PIPE 1" BSP

## IN THE BOX

- CONNECTOR
- INSTRUCTION MANUAL

## DETAILS



MESH STRAINER



INTEGRATED VALVE

## DIMENSIONS

### EXTENSIBLE PIPE PLASTIC MADE



940mm

### EXTENSIBLE STEEL PIPE 1" BSP



1100mm

### 2" CONNECTOR



### 2" QUICK CONNECTOR

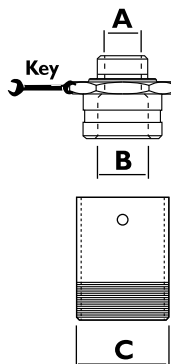

Dimensions expressed in millimeters

## TECHNICAL DATA

CODE	DESCRIPTION	FLUIDS TYPE	INTEGRATED VALVE	FILTER	INLET	OUTLET	THREADED FLANGE	A	B	C	KEY
					BSP	BSP	BSP	BSP	BSP	BSP	
<b>2" CONNECTOR</b>											
F17163000	DRUM CONNECTOR WITH INTEGRATED VALVE	D G K O	YES	YES	2"	-	NO	1"	1"	2"	-
F17190000	DRUM CONNECTOR WITHOUT INTEGRATED VALVE	D G K O	NO	YES	2"	-	NO	1"	1"	2"	-
F17163010	DRUM CONNECTOR WITH FLANGED AND INTEGRATED VALVE	D G K O	YES	YES	2"	1"	YES	1"	1"	2"	-
<b>2" QUICK COUPLING</b>											
R09160000	QUICK COUPLING 3/4"	D O	NO	NO	3/4"	1"	NO	M 3/4"	F 1"	M 2"	60
F0893000A	QUICK COUPLING 1"	D O	NO	NO	1"	1"	NO	M 1"	F 1"	M 2"	60
<b>EXTENSIBLE PIPE</b>											
F08934000	EXTENSIBLE SUCTION PIPE 1" 940MM PLAST.	D G K O	-	-	1"	1"	-	-	-	-	-
F08934010	KIT EXTENSIBLE SUCTION PIPE 1" 1800MM	D G K O	YES	YES	2"	1"	YES	1"	1"	2"	-
F08934020	EXTENSIBLE SUCTION PIPE 1" 1100MM STEEL	D G K O	-	-	1"	1"	-	-	-	-	-



FUEL MANAGEMENT SYSTEMS



DISPENSERS



KITS



PUMPS



METERS



NOZZLES

# COUPLING & FITTINGS

## FEATURES

- EASY TO USE
- VERSATILITY AND SEVERAL SHAPES

PIUSI COUPLING & FITTINGS are engineered to fit every application context representing the perfect solution to connect the fuel equipment.

### TECHNICAL DATA

CODE	DESCRIPTION	INLET / OUTLET			KEY		Q.TY
		A	B	C	1	2	

### ELBOWS

FO7806000	ELBOW F 3/4" BSP / F 3/4" BSP	F 3/4" BSP	F 3/4" BSP	-	-	-	-
FO7805000	ELBOW M 3/4" BSP / F 3/4" BSP	M 3/4" BSP	F 3/4" BSP	-	-	-	-
FO8609000	ELBOW F 1" BSP / F 1" BSP - BRASS	F 1" BSP	F 1" BSP	-	-	-	-
FO7988000	ELBOW M 1" BSP / F 1" BSP - BRASS	M 1" BSP	F 1" BSP	-	-	-	-
FI4567000	ELBOW ROTATING CONNECTOR 90° 1" M/F	M 1" BSP	F 1" BSP	-	-	-	-



ROTATING ELBOWS



ELBOWS

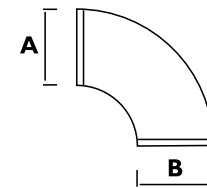

### HOSE TAILS

FO826700A	HOSETAIL 1/2" X D.20 + OR	1/2" BSP	19 MM	-	24	-	1
FO643700A	HOSETAIL 3/4" X D.20 + OR (20 PCS)	3/4" BSP	19 MM	-	32	-	20
FO776800B	HOSETAIL 3/4" X D.25 + OR (20 PCS)	3/4" BSP	25 MM	-	32	-	20
FO775700A	HOSETAIL 1" X D.20 + OR (20 PCS)	1" BSP	19 MM	-	37	-	20
FO776400A	HOSETAIL 1" X D.25 + OR (20 PCS)	1" BSP	25 MM	-	37	-	20



HOSE TAILS

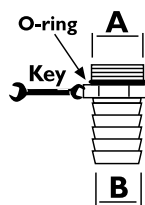

### HQC

		KG.	MM.	PCS/BOX
FO0636000	HQC - HOSE QUICK COUPLING 1" BSP	0,46	80X80X75	1



HQC

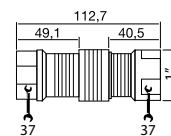

### SEALANT PASTE

		GR.	ML.
FO8173000	ADEHESIVE PASTE LOXEAL 18-10 - LIGHT REMOVABLE	130	-
FI0767000	THREAD SEALANT BLUE LOXEAL 55.03 - MEDIUM REMOVABLE	-	250
FI2278000	THREAD SEALANT GREEN LOXEAL 85.21 - HEAVY NON REMOVABLE	-	250



SEALANT PASTE



FILTRATION



TANK MONITORING



HOSE REEL



ACCESSORIES



MERCHANDISE



INDEX



ANY BIODIESEL



AIR



ANTIFREEZE



AdBlue®



BIODIESEL



DIESEL



FOOD



GASOLINE



GREASE



KEROSENE



OIL



WATER



WINDSCREEN

## TECHNICAL DATA

CODE	DESCRIPTION	INLET / OUTLET			KEY		Q.TY
		A	B	C	1	2	

## SLEEVE

FO8137000	SLEEVE HOSE DIAM. 20	28 MM	20 MM	-	-	-	1
FO8138000	SLEEVE HOSE DIAM. 25	36 MM	28 MM	-	-	-	1
FI7126000	SLEEVE F 1" BSP / F 1" BSP (20 PCS)	F 1" BSP	F 1" BSP	-	-	-	20



SLEEVE

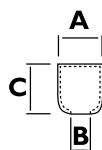

## COUPLINGS

FO7762000	NIPPLE M 3/4" BSP / M 1" BSP	M 3/4" BSP	M 1" BSP	-	34	-	-
FO8913000	NIPPLE M 1" BSP - M 1/2" BSP	M 1" BSP	M 1" 1/2" BSP	-	30	-	-
FO7765000	NIPPLE M 1" BSP / M 1" BSP	M 1" BSP	M 1" BSP	-	34	-	-
FO7766000	NIPPLE M 3/4" BSP / M 3/4" BSP	M 3/4" BSP	M 3/4" BSP	-	34	-	-



NIPPLE

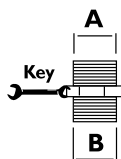

NIPPLE

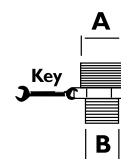

## FITTINGS

FO7441000	FITTING M 3/4" BSP F 1/2" BSP	F 1/2" BSP	M 3/4" BSP	-	27	-	-
FO7760000	FITTING M 3/4" BSP / F 1" BSP	F 3/4" BSP	M 1" BSP	-	34	-	-
FO7889000	FITTING F 1" BSP / M 3/4" BSP	F 1" BSP	M 3/4" BSP	-	-	-	-
FI425800A	ADAPTER FOR TANK 2" X D.36	F 2" BSP	D.36	-	-	-	-

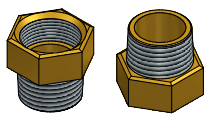

FITTINGS

## SWIVEL UNION

000890000	SWIVEL UNION M 3/4" BSP X 27MM	3/4" BSP	19 MM	27 MM	38 MM	38 MM	-
000891000	SWIVEL UNION M 1" BSP X 27MM	1"	19 MM	27 MM	31 MM	31 MM	-
FO0892000	SWIVEL UNION M 1" BSP X 35MM	1"	25 MM	35 MM	38 MM	38 MM	-



UNION



1



2



3



4

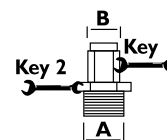
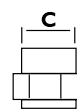



FUEL MANAGEMENT SYSTEMS



DISPENSERS



KITS



PUMPS



METERS



NOZZLES

# FLANGED CONNECTIONS

## FEATURES

- STURDY DESIGN
- EASY TO FIT
- SEVERAL SHAPES

Safe and guaranteed solutions to connect products: connections, elbows, full kits and flanges.

## TECHNICAL DATA

CODE	DESCRIPTION	INLET / OUTLET				FLANGE	O-RING	OVAL RING	SCREW		GRUB SCREW	NUT
		A	B	C	H				M8X20 N°	M8X30 N°		

## FLANGES

FO883200A	FLANGE D.80 1" E80/E120	-	1" BSP	80 MM	18 MM	-	-	-	-	-	-	-
F1290400A	KIT FLANGE 1" BSP	-	1" BSP	80 MM	18 MM	1	-	1	-	2	-	2
FO918000A	KIT FLANGE 1" BSP (2 PCS)	-	1" BSP	80 MM	18 MM	2	2	-	4	-	-	-
F1106200B	KIT FLANGE CUBE 70	-	1" BSP	80 MM	18 MM	1	1	-	2	-	-	-
RO841700O	KIT N°2 OR SEAL 3156	-	-	-	-	-	2	-	-	-	-	-
F1444500A	KIT FLANGE 3/4" BSP (2 PCS)	-	3/4" BSP	80 MM	18 MM	2	2	-	4	-	-	-
FO898500A	OR SEAL 3156 , OVAL SECTION	-	-	-	-	-	-	1	-	-	-	-
RO977900A	KIT FLANGE FOR PANTHER WITH K33	-	-	-	-	1	2	-	-	-	2	2
FO804300O	SCREW M8X30 N°10 PIECES	-	-	-	-	-	-	-	-	10	-	-
F1290600A	FLANGED KIT WITH NUT	-	-	-	-	1	-	-	-	-	-	2



FLANGE

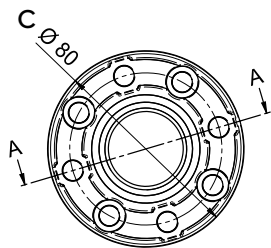

SCREW



NUT



FLANGE



O-RING



OVAL RING



GRUB SCREW

FLANGE KIT

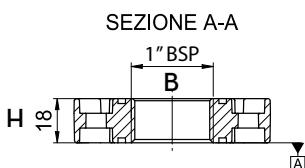



FILTRATION



TANK MONITORING



HOSE REEL



ACCESSORIES



MERCHANDISE



INDEX



ANY BIODIESEL



AIR



ANTIFREEZE



AdBlue®



BIODIESEL



DIESEL



FOOD



GASOLINE



GREASE



KEROSENE



OIL



WATER



WINDSCREEN

### TECHNICAL DATA

CODE	DESCRIPTION	DIMENSIONS	FLANGE	O-RING	OVAL RING	SCREW				GRUB SCREW	NUT
		LENGTH	N°	N°	N°	M8X16 N°	M8X20 N°	M6X16 N°	M8X30 N°	M8X50 N°	M8 N°

### FLANGED TUBE

F1217200A	FLANGED TUBE 341MM\$	341	-	-	-	-	-	-	-	-	-
F1222800B	FLANGED TUBE 300MM	300	-	-	-	-	-	-	-	-	-
R13251000	KIT TUBO RACC-FLANG. SELF.S. TANK FM+MC	205	-	2	-	2	2	-	-	-	-

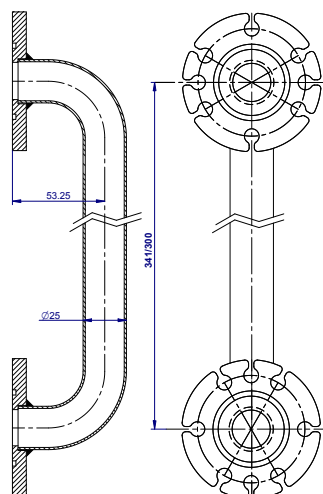

FLANGED TUBE 300/341



### TECHNICAL DATA

CODE	DESCRIPTION	DIMENSIONS	FLANGE	O-RING	OVAL RING	SCREW				GRUB SCREW	NUT
		LENGTH	N°	N°	N°	M8X16 N°	M8X20 N°	M6X16 N°	M8X30 N°	M8X50 N°	M8 N°

### FLANGED ELBOW

F1082400A	KIT FLANGED ELBOW + OR + SCREW	-	-	2	-	-	2	-	2	-	2
-----------	--------------------------------	---	---	---	---	---	---	---	---	---	---

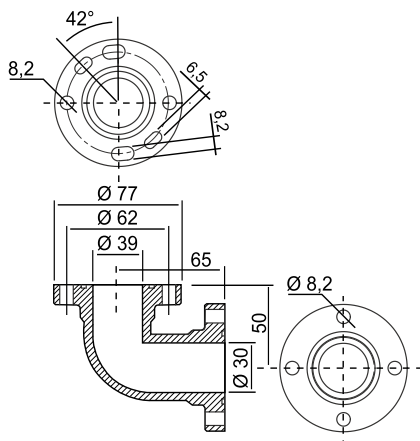

ELBOW



SCREW



NUT



FLANGE



O-RING



FUEL MANAGEMENT SYSTEMS



DISPENSERS



KITS



PUMPS



METERS



NOZZLES

# HOSE & SWIVEL

Diesel fuel delivery hoses, suction hoses, crimped hoses, rotating hose connectors: a wide range to complete the accessories product range.

## TECHNICAL DATA

CODE	DESCRIPTION	FLUIDS TYPE	PRESSURE		VACUUM	DIMENSIONS				KEY	CAMLOCK
			BAR	PSI	BAR	A MM	B MM	S MM	L M/FT.		MALE/FEMALE BSP

### DELIVERY HOSES

FO060500A	DIESEL HOSE D.20 80MT	D	10	-	-	20	27	-	80	-	-
FO060502A	DIESEL HOSE Ø20 PARKER 80 MT	D	10	-	-	20	27	-	80	-	-
FO060600A	DIESEL HOSE D.25 40MT	D	10	-	-	25	35	-	40	-	-
FO060602A	DIESEL HOSE Ø25 PARKER 40MT	D	10	-	-	25	35	-	40	-	-
F23554000	HOSE B100 D.20 60M	D B	12	-	-	-	-	20	60	-	-
F23555000	HOSE B100 D.25 60M	D B	12	-	-	-	-	25	60	-	-

### DELIVERY CRIMPED HOSES

F11885000	DIESEL HOSE Ø20 L=4M CRIMPED 3/4"X3/4"	D	10	-	-	3/4" BSP	3/4" BSP	20	4	-	-
FO8561000	DIESEL HOSE Ø20 L=4M CRIMPED 3/4"X1"	D	10	-	-	3/4" BSP	1" BSP	20	4	-	-
FO8976000	DIESEL HOSE Ø20 L=4M CRIMPED 1"X1"	D	10	-	-	1" BSP	1" BSP	20	4	-	-
F12876000	DIESEL HOSE Ø20 L=6M CRIMPED 3/4"X3/4"	D	10	-	-	3/4" BSP	3/4" BSP	20	6	-	-
F11063000	DIESEL HOSE Ø20 L=6M CRIMPED 3/4"X1"	D	10	-	-	3/4" BSP	1" BSP	20	6	-	-
FO8945000	DIESEL HOSE Ø20 L=6M CRIMPED 1"X1"	D	10	-	-	1" BSP	1" BSP	20	6	-	-
F11060000	DIESEL HOSE Ø20 L=7M CRIMPED 1"X1"	D	10	-	-	1" BSP	1" BSP	20	7	-	-
F12323000	DIESEL HOSE Ø20 L=8M CRIMPED 1"X1"	D	10	-	-	1" BSP	1" BSP	20	8	-	-
F11532000	DIESEL HOSE Ø20 L=10M CRIMPED 3/4"X1"	D	10	-	-	3/4" BSP	1" BSP	20	10	-	-
F12929000	DIESEL HOSE Ø20 L=10M CRIMPED 1"X1" PARKE	D	10	-	-	1" BSP	1" BSP	20	10	-	-
F16367000	DIESEL HOSE D.25 CRIMPED 1"/1" 1MT	D	10	-	-	1" BSP	1" BSP	25	1	-	-
F1815100A	GASOLINE HOSE D.20 CRIMPED 1"/1" 4MT	D	10	-	-	1" BSP	1" BSP	20	4	-	-
FO8976040	PARKER HOSE D20 CRIMPED 3/4" X 1" 2 MT	D	10	-	-	3/4" BSP	1" BSP	20	2	-	-
F17254000	PARKER HOSE D20 CRIMPED 1" BSP 10 MT	D	10	-	-	-	1" BSP	20	10	-	-
F12794000	DIESEL HOSE Ø25 L=2M CRIMPED 1"X1"	D	10	-	-	1" BSP	1" BSP	25	2	-	-
FO8560000	DIESEL HOSE Ø25 L=3M 1"X1"	D	10	-	-	1" BSP	1" BSP	25	3	-	-
FO8977000	DIESEL HOSE Ø25 L=4M CRIMPED 1"X1"	D	10	-	-	1" BSP	1" BSP	25	4	-	-
F11264000	DIESEL HOSE Ø25 L=5M CRIMPED 1"X1"	D	10	-	-	1" BSP	1" BSP	25	5	-	-
FO8858000	DIESEL HOSE Ø25 L=6M CRIMPED 1"X1"	D	10	-	-	1" BSP	1" BSP	25	6	-	-
F12784000	DIESEL HOSE Ø25 L=7M CRIMPED 1"X1"	D	10	-	-	1" BSP	1" BSP	25	7	-	-
F11540000	DIESEL HOSE Ø25 L=8M CRIMPED 1"X1"	D	10	-	-	1" BSP	1" BSP	25	8	-	-
F12785000	DIESEL HOSE Ø25 L=10M CRIMPED 1"X1"	D	10	-	-	1" BSP	1" BSP	25	10	-	-
F14412000	DIESEL HOSE Ø25 L=12M CRIMPED 1"X1"	D	10	-	-	1" BSP	1" BSP	25	12	-	-
F23556000	HOSE B100 D.20 L=6M 1"X1"	D B	12	-	-	1" BSP	1" BSP	20	6	-	-
F23607000	HOSE B100 D.25 L=6M 1"X1"	D B	12	-	-	1" BSP	1" BSP	25	6	-	-



DISPENSING HOSES



RUBBER HOSE



RUBBER SUCTION HOSE



PVC HOSE

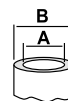

CRIMPED HOSE

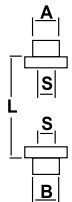

### BENDING PROTECTION

F20889000	BENDING PROTECTION 1"
F18568000	PROTEZIONE PIEGATURA TUBO 3/4"





FILTRATION



TANK MONITORING



HOSE REEL



ACCESSORIES



MERCHANDISE



INDEX



ANY BIODIESEL



AIR



ANTIFREEZE



AdBlue®



BIODIESEL



DIESEL



FOOD



GASOLINE



GREASE



KEROSENE



OIL



WATER



WINDSCREEN

### TECHNICAL DATA

CODE	DESCRIPTION	FLUIDS TYPE	PRESSURE		VACUUM	DIMENSIONS				KEY	CAMLOCK
			BAR	PSI	BAR	A MM	B MM	S MM	L M/FT.		MALE/FEMALE BSP

### SUCTION HOSES

F12120010	SUCTION SPIRAL HOSE D.25 60MT	D B O	10	-	-0,9	25	35	-	60	-	-
F1113100B	SUCTION SPIRAL PVC HOSE D.25 60MT	D O	10	-	-0,9	25	33	-	60	-	-

### SUCTION CRIMPED SPIRAL HOSES

F12117000	SUCTION SPIRAL HOSE D.25 CRIMP 1"/1" 1MT	D B O	10	-	-0,9	1" BSP	1" BSP	25	1	-	-
F12118000	SUCT SPIRAL HOSE D.25 CRIMP 1"/1" 1.5MT	D B O	10	-	-0,9	1" BSP	1" BSP	25	1,5	-	-
F12119000	SUCTION SPIRAL HOSE D.25 CRIMP 1"/1" 2MT	D B O	10	-	-0,9	1" BSP	1" BSP	25	2	-	-
F13768000	SUCT SPIRAL HOSE D.25 CRIMP 1"/1" 3.5MT	D B O	10	-	-0,9	1" BSP	1" BSP	25	3,5	-	-
F13695000	SUCTION SPIRAL HOSE D.25 CRIMP 1"/1" 5MT	D B O	10	-	-0,9	1" BSP	1" BSP	25	5	-	-
F1640400A	KIT SUCT SPIRAL HOSE D.25 W/VALVE 4MT	D B O	10	-	-0,9	1" BSP	1" BSP	25	4	-	-

### SUCTION CRIMPED PVC SPIRAL HOSES

F1113200A	TRAS. PVC HOSE Ø25 L=1.6M CRIMPED 1"X1"	D O	5	-	-0,9	1" BSP	1" BSP	25	1,6	-	-
F11637000	TRAS. PVC HOSE Ø25 L=3M CRIMPED 1" X1"	D O	5	-	-0,8	1" BSP	1" BSP	25	3	-	-
F11213010	TRAS. PVC HOSE Ø25 L=1,9M 1"X1" + FV	D O	5	-	-0,8	1" BSP	1" BSP	25	1,9	-	-
F11638010	TRAS. PVC HOSE Ø25 L=4M 1"X1" + FV	D O	5	-	-0,9	1" BSP	1" BSP	25	4	-	-



RUBBER HOSE



SPIRAL RUBBER HOSE



SPIRAL PVC HOSE

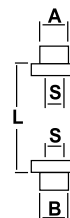

### HOSE KIT 1" 1/2

F18798000	KIT HOSE 1 1/2" 10 MT+CAMLOCK+HOSETAIL	D	10	145	-	1" 1/2 BSP	-	-	-	-	1" 1/2 BSP
F18799000	KIT HOSE 1 1/2" 20 MT+CAMLOCK+HOSETAIL	D	20	65,6	-	1" 1/2 BSP	-	-	-	-	1" 1/2 BSP
F14390010	KIT 1" BSP MF CAMLOCK	D	-	-	-	1" BSP	-	-	-	-	1" BSP

HOSE KIT 1" 1/2



CAMLOCK

### SWIVEL

000623000	SWIVEL M .- BSP / M 1" BSP	-	-	-	-	M 3/4" BSP	M 1" BSP	-	-	94	-
00062400A	SWIVEL M .- BSP / F .- BSP	-	-	-	-	M 3/4" BSP	F 3/4" BSP	-	-	38	-
FOO62000A	SWIVEL M .- BSP / F 1" BSP	-	-	-	-	M 3/4" BSP	F 1" BSP	-	-	34	-
FOO62200A	SWIVEL M 1" BSP / F 1" BSP	-	-	-	-	M 1" BSP	F 1" BSP	-	-	34	-
FOO623100	SWIVEL M .- BSP / M 1" BSP W/FILTER	-	-	-	-	M 3/4" BSP	M 1" BSP	-	-	94	-
FOO62500A	SWIVEL M .- BSP X 20MM	-	-	-	-	M 3/4" BSP	20MM	-	-	38	-
FO845600A	SWIVEL M 1/2" BSP F 1/2" BSP	-	-	-	-	M 1/2" BSP	F 1/2" BSP	-	-	25	-

SWIVEL



ROTATING HOSE CONNECTORS

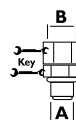



# ACCESSORIES

## ACCESS CONTROL

ACCESS 85	CODE	DESCRIPTION
	F1249600A	MANAGER KEY 2018
	F1590400A	KIT DRIVER KEY YELLOW (10PCS)
	F1623900B	NOZZLE HOLDER SS-CABLED SWITCH FM/MC
	F17121000	LEVEL PROBE FOR ACCESS 85









**MERCHANDISE**





FUEL MANAGEMENT SYSTEMS



DISPENSERS



KITS



PUMPS



METERS



NOZZLES

# MERCHANDISE



## PACKAGING

CODE	DESCRIPTION	WEIGHT		PACKAGING			
		KG	LBS	MM	INCH	PCS/PALLET	PCS/BOX
<b>T-SHIRT WHITE</b>							
PBG000026	PIUSI T-SHIRT WHITE BOX 10 PCS - L	1	-	35X26X18	-	-	10
PBG000027	PIUSI T-SHIRT WHITE BOX 10 PCS - XL	1	-	35X26X18	-	-	10
PBG000029	PIUSI T-SHIRT WHITE BOX 10 PCS - M	1	-	35X26X18	-	-	10
<b>UMBRELLA</b>							
PBG000030	PIUSI UMBRELLA - BOX 10 PCS	5,5	-	35X26X18	-	-	10
<b>BAG</b>							
PBG000035	PIUSI BAG 2018 - BOX 150 PCS	18,5	-	-	-	-	150
<b>KEYRING</b>							
PBG000041	PIUSI KEYRING - BOX 100 PCS	-	-	-	-	-	100



FILTRATION



TANK MONITORING



HOSE REEL



ACCESSORIES



MERCHANDISE

# PIUSI

INDEX



## PACKAGING

CODE	DESCRIPTION	WEIGHT		PACKAGING			
		KG	LBS	MM	INCH	PCS/PALLET	PCS/BOX
<b>METALLIC FLOOR STAND</b>							
PBA000013	PIUSI METALLIC FLOOR STAND	76	-	120X100 (PALLET)	-	1	-
<b>PIUSI FLAG</b>							
PBA000030	DROP DISPLAY PIUSI - ADV	8	-				1

# PIUSI FLUIDS' INFORMATION

## ATEX/IECEX DIRECTIVE

### SAFETY IN EXPLOSIVE ENVIRONMENTS

As of 1st July 2003, the ATEX directive came into force throughout the EEC. This directive became an obligatory requirement for all electrical and mechanical equipment intended for use in dangerous areas. Potentially explosive atmospheres exist where there is a risk of explosion due to mixtures of gas and air, steam and air, dust and air or other flammable combinations typical of petrol vapours.

If the electrical or mechanical material must be used in areas where there is an explosive atmosphere, it must be designed and built so as not to create/ to eliminate sources of ignition such as sparks, hot surfaces or static electricity and all sources of combustion able to ignite these mixtures. Risk areas for environments where gas and flammable vapours are present can range from AREA 0 (constant risk of explosion) to AREA 1 (risk of explosion probable) and AREA 2 (low risk and any risk of explosion persists for a short time only).

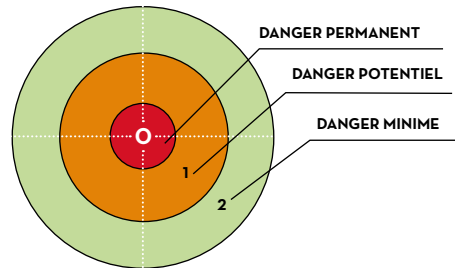
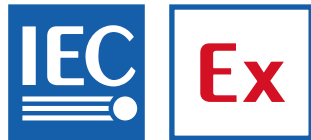

OUR PUMPS COMPLIES WITH THE FOLLOWING MARKING ATEX/IECEX

II	2	G	Ex	d	IIA	T4	Gb
GROUP	CATEGORY	TYPE OF EXPLOSIVE ATMOSPHERE	PERMANENT PREFIX	PROTECTION METHOD	GAS GLASS	TEMPERATURE CLASS	EQUIPMENT PROTECTION LEVEL

II = Group II comprises appliances intended for use in other environments (other than mining) in which explosive atmospheres are probable.

2 = High protection, Category 2 for AREA 1 GAS and AREA 2 GAS

G = Gas

Ex = Explosion-proof equipment certified according to the European ATEX directives

d = Explosion-proof cases (EN 60079-1)

IIA = Electrical appliances for potentially explosive environments other than mining. (Propane, Butane etc.)

T4 = The temperature of the pump will not exceed 135°C

PIUSI 's experience in the world of flammable liquids

PIUSI renews his natural propension to find solutions for the transfer of fluids, expanding its range with new products to dispensing flammable liquids.

Experience gained with pumps for transferring diesel fuel, combined with the growing demands of the market, have fostered the development of this new range of pumps for gasoline, kerosene and diesel, that satisfy the criteria of strict ATEX directives concerning the use of materials in potentially explosive atmospheres.

The PIUSI products have successfully obtained certification CESI and IECEX Certificate of Conformity.

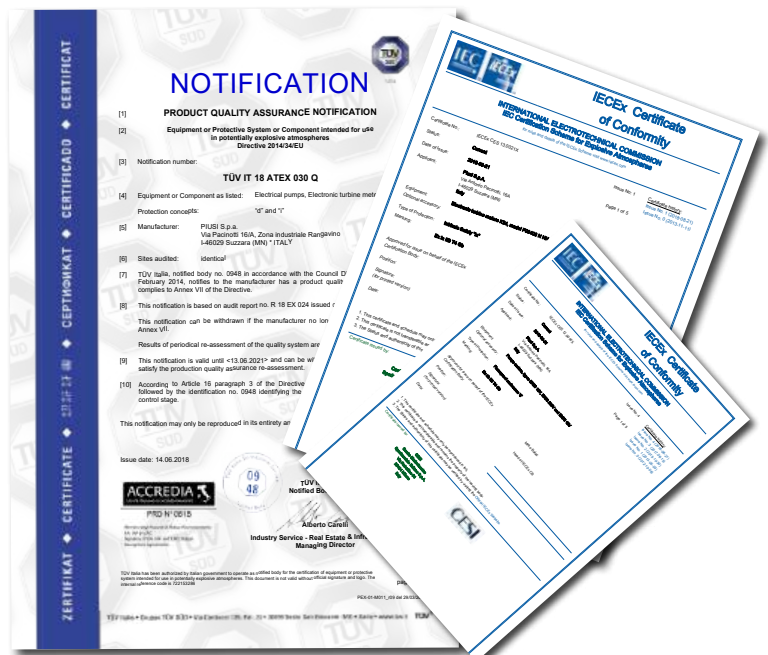

## TYPE OF FLUIDS

<b>AIR</b>	<b>A</b>
<b>ANTIFREEZE</b>	<b>A</b>
<b>AdBlue® (UREA)</b>	<b>Ad</b>
<b>BIODIESEL</b>	<b>B</b>
<b>DIESEL</b>	<b>D</b>
<b>FOOD</b>	<b>F</b>
<b>GASOLINE</b>	<b>G</b>
<b>GREASE</b>	<b><sup>R</sup>G</b>
<b>KEROSENE</b>	<b>K</b>
<b>OIL</b>	<b>O</b>
<b>WATER</b>	<b>W</b>
<b>WINDSCREEN</b>	<b><sup>S</sup>W</b>

The intellectual property of this catalogue is assigned to all countries. Translation, reproduction, electronic storage and full or partial adaption by any means (including microfilms and photocopies) of its contents, without prior written authorisation from PIUSI S.p.a., entails a violation of PIUSI S.P.A's copyrights and constitutes an act of unfair competition. The products shown in the images of this catalogue are protected according to the regulation in force regarding industrial property. The information contained in this catalogue is as accurate as possible and complies, as far as possible, with existing regulations at the time of its publication. We therefore reserve the right to make subsequent modifications in line with modifications to regulations and/ or in relation to any production requirements that are deemed necessary for safety reasons. The technical specifications indicated in this catalogue cancel out and replace those already present in the previous general catalogue and in the product catalogues. The updates and product data sheets are available in PDF format on our website: [www.piusi.com](http://www.piusi.com)

Since 1953, piusi has been employing italian engineering skills at the service of its customers, with professionalism and integrity in order to build stable and lasting relationships.

Our mission is to provide simple, intelligent and professional solutions for the transfer, dispense and measurement of lubricants, fuels and liquids, with the highest consideration for human and environmental health.



**PIUSI S.p.A.**

Headquarters  
46029 Suzzara (Mantova) Italy  
tel.+39 0376 534561  
e-mail: [piusi@piusi.com](mailto:piusi@piusi.com)  
[www.piusi.com](http://www.piusi.com)

**PIUSI USA, Inc.**

3901 Anglers Avenue Fort Lauderdale, FL 33312  
tel.: 954 584 1552  
e-mail: [piusiusa@piusi.com](mailto:piusiusa@piusi.com)  
[www.piusi.com](http://www.piusi.com)

