



FUEL MANAGEMENT SYSTEMS



DISPENSERS



KITS



PUMPS



METERS



NOZZLES

K150 ATEX



FEATURES

- HEAVY DUTY CONDITIONS
- HIGH FLOW RATE
- BURSTING PRESSURE 28 BAR
- EASY READING
- 4 FLOW DIRECTIONS

K150 ATEX is expressly engineered to meet the market requirements of a meter suitable for flow rates superior than 120 l/min and that can be used both for fluids such as diesel and biodiesel, as well as in potentially explosives atmosphere; with gasoline for example. K150 is easy to calibrate and ready to use; its aluminium cover and sturdy body make this meter suitable for a wide arrange of application while guaranteeing the same precision and quality that have always featured PIUSI equipment. The mechanical display allows to read quickly the quantity dispensed. It can be installed everywhere thanks to the (optional) 1" BSP flange kit. K150 is certified CE, ATEX/UL and tested in PIUSI laboratories for over 4 milion litres to guarantee the maximum reliability.

PERFORMANCE

UP TO 25-150 L/MIN FLOW RATE	3,5 BAR MAX OPERATING PRESSURE
± 1% ACCURACY	0,3% REPEATABILITY



K150

OUR PRODUCTS COMPLIES WITH THE FOLLOWING MARKING ATEX

II GROUP	2 CATEGORY	G TYPE OF EXPLOSIVE ATMOSPHERE	c PROTECTION METHOD	IIB GAS GLASS	T6 TEMPERATURE CLASS
--------------------	----------------------	--	-------------------------------	-------------------------	--------------------------------

PACKAGING

CODE	WEIGHT		PACKAGING			BOXES/EUOPALLET	
	KG	LBS	MM	INCH	PCS/BOX		
FO0555A00	2,38	5,25	185X185X170	7,28X7,28X6,69	1	192	240
FO0555B00	2,38	5,25	185X185X170	7,28X7,28X6,69	1	192	240
FO0555C00	2,38	5,25	185X185X170	7,28X7,28X6,69	1	192	240
FO0555D00	2,38	5,25	185X185X170	7,28X7,28X6,69	1	192	240



FILTRATION



TANK MONITORING



HOSE REEL



ACCESSORIES



MERCHANDISE

PIUSI



ANY BIODIESEL



AIR



ANTIFREEZE



AdBlue®



BIODIESEL



DIESEL



FOOD



GASOLINE



GREASE



KEROSENE



OIL



WATER



WINDSCREEN

CHART

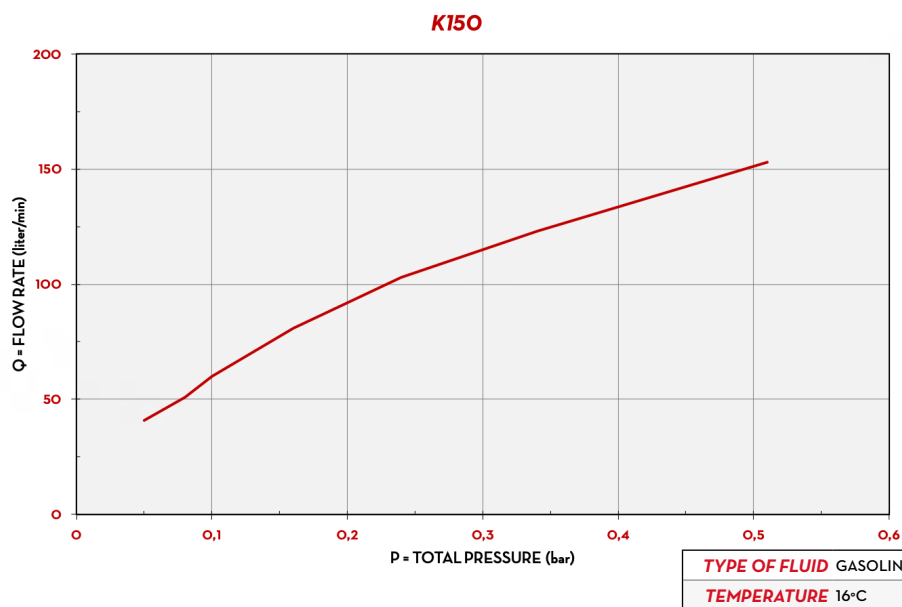

DIMENSIONS

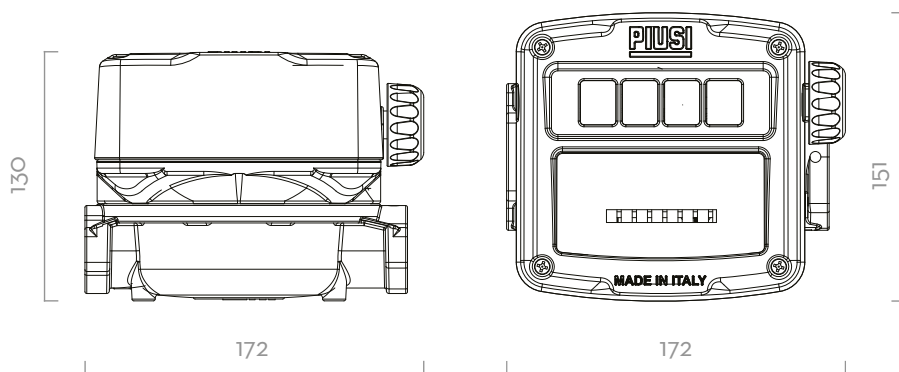

Dimensions expressed in millimeters

IN THE BOX

- K150 ATEX METER
- INSTRUCTION MANUAL

DETAILS

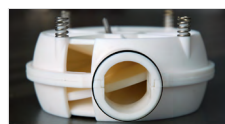

NUTATING DISK



4 FLOW DIRECTIONS



ATEX APPROVED



METALLIC COVER

MATERIALS

- BODY AND COVER: ALUMINIUM
- NUTATING DISK CHAMBER: TECHNOPOLYMER

TECHNICAL DATA

CODE	DESCRIPTION	FLUIDS TYPE	FLOW RATE		FLOW DIRECTIONS	PRESSURE		INLET/OUTLET
			L/MIN	GPM		BAR	PSI	
FO055A00	(EX) K150 METER VER.A ATEX	D G K	25-150	6,6-40	←	3,5	50	1" BSP
FO055B00	(EX) K150 METER VER.B ATEX	D G K	25-150	6,6-40	↑	3,5	50	1" BSP
FO055C00	(EX) K150 METER VER.C ATEX	D G K	25-150	6,6-40	↓	3,5	50	1" BSP
FO055D00	(EX) K150 METER VER.D ATEX	D G K	25-150	6,6-40	→	3,5	50	1" BSP

COMPATIBLE FLUIDS: DIESEL, KEROSENE, PETROL, PETROL/ALCOHOL MIXTURE (MAX 20%), AVGAS 100/100LL (PUMP AND FLOW METER ONLY), JET A/A1 (PUMP AND FLOW METER ONLY), ASPEN 2/4. VERSION WITH UL APPROVAL FOR ASPEN 2/4 AVAILABLE.